

OPERATION MANUAL

Multichannel amplifier Model 9235/36

©2010 burster
präzisionsmesstechnik gmbh & co kg
All rights reserved

Manufacturer:
burster praezisionsmesstechnik gmbh & co kg
Talstrasse 1 – 5 P.O. Box 1432
76593 Gernsbach, 76587 Gernsbach,
Germany Germany

Valid from: 2010-03-23

Tel.: (+49) 07224 / 6450
Fax.: (+49) 07224 / 64588
E-Mail: info@burster.de
www.burster.de

Note:

Exclusion of warranty liability for operating manuals

All information in the present documentation was prepared and compiled with great care and reproduced subject to effective control measures. No warranty is provided for freedom from errors. We reserve the right to make technical changes. The present information as well as the corresponding technical data can change without notice. Reproduction of any part of this documentation or its processing or revision using electronic systems is prohibited without the manufacturer's prior written approval.

Components, devices and measured value sensors made by burster praezisionsmesstechnik (hereinafter referred to as "product") are the results of targeted development and meticulous research. As of the date of delivery, burster provides a warranty for the proper condition and functioning of these products covering material and production defects for the period specified in the warranty document accompanying the product. However, burster excludes guarantee or warranty obligations as well as any liability beyond that for consequential damages caused by improper use of the product, in particular the implied warranty of success in the market as well as the suitability of the product for a particular purpose. Furthermore, burster assumes no liability for direct, indirect or incidental damages as well as consequential or other damages arising from the provision and use of the present documentation.

Präzisionsmessgeräte, Sensoren und Messsysteme
für elektrische, thermische und mechanische Größen



EG-Herstellererklärung

EC- Certificate of manufacture Conformity according to EN ISO/IEC 17050-1:2004

Name des Herstellers: burster präzisionsmesstechnik gmbh & co kg
Manufacturer's Name:

Adresse des Herstellers: Talstr. 1-5
Manufacturer's Address: 76593 Gernsbach, Germany

erklärt unter alleiniger Verantwortung, dass das gelieferte Produkt
declares under sole responsibility that the product as originally delivered

Produktname: In-Line-Messverstärker für DMS-Sensoren
Product Name: In-Line Amplifier for Strain Gauge Sensors

Modellnummer(n) (Typ): 9235
Models Number / Type:

Produktoptionen: Diese Erklärung beinhaltet obengenannte Produkte mit allen Optionen
Options *This declaration covers all options of the above product(s)*

mit den folgenden europäischen Richtlinien übereinstimmt und entsprechend das CE-Zeichen trägt:
complies with the requirements of the following applicable European Directives, and carries the CE marking accordingly:

2006/95/EC Elektrische Betriebsmittel zur Verwendung innerhalb bestimmter Spannungsgrenzen
Low Voltage *Electrical Equipment designed for use within certain voltage limits*

2004/108/EC Elektromagnetische Verträglichkeit
EMC *Electromagnetic Compatibility*

Obengenannte Produkte entsprechen folgenden harmonisierten Normen:
Above named products conform with the following product standards:

Sicherheit: IEC 61010-1:2001 / EN 61010-1:2001 Messkategorie I Schutzklasse III
Safety requirements: CAT 1 *Safety class 3*

EMV Störaussendung: IEC/CISPR 11:2003 + A1:2004 + A2:2006 / EN 55011:2007 + A2:2007
EMC Generic emission:

EMV Störfestigkeit: IEC 61326-1:2005 / EN 61326-1:2006 Industrie Bereich
EMC Generic immunity: *Industrial environment*

Ergänzende Informationen: / Additional Information:

Das Produkt wurde in einer typischen Konfiguration getestet. Die Inbetriebnahme ist solange untersagt, bis festgestellt wurde, dass das Endprodukt, in welches unser Erzeugnis eingebaut werden soll, den Bestimmungen der EG-Richtlinien entspricht. Um optimale Störfestigkeit zu erreichen ist das Produkt über geschirmte Leitungen anzuschließen. *Das Produkt benötigt weniger als 50 Watt.
*The product was tested in a typical configuration. The initiation is prohibited until it can be stated that the final product, in which our product shall be installed, corresponds to the definitions of the EC guidelines. In order to reach optimal electromagnetic immunity the device has to be conducted with shielded line. *The product requires less than 50 W.*

Diese Konformitätserklärung betrifft alle nach Ausstellungsdatum ausgelieferten Produkte:
This DoC applies to above-listed products placed on the EU market after:

Gernsbach 09.07.2008 i. V. Alfred Großmann
Datum / date *Quality Manager*

Dieses Dokument ist entsprechend EN ISO/IEC 17050-1:2004 Abs. 6.1g ohne Unterschrift gültig / According EN ISO/IEC 17050 this document is valid without a signature.

burster präzisionsmesstechnik gmbh & co kg · Talstr. 1-5 · D-76593 Gernsbach (Postfach 1432 D-76587 Gernsbach) Tel. 07224/645-0 Fax 645-88
www.burster.de · www.burster.com · info@burster.de

Sitz der Gesellschaft: HRA 530170 Mannheim Komplementär: burster präzisionsmesstechnik Verwaltungs-GmbH Sitz der Gesellschaft: Gernsbach HRB 530130 Mannheim
Geschäftsführer: Matthias Burster Prokurist: Edgar Migler UST-Identnr.: DE 144 005 098 Steuernr.: 39454/10503
Dresdner Bank AG Rastatt Kto. 08 307 073 00 BLZ 682 800 53 Volksbank Baden-Baden* Rastatt eG Kto. 302 082 00 BLZ 662 900 00



Präzisionsmessgeräte, Sensoren und Messsysteme
für elektrische, thermische und mechanische Größen



EG-Herstellererklärung

EC- Certificate of manufacture Conformity according to EN ISO/IEC 17050-1:2004

Name des Herstellers: burster präzisionsmesstechnik gmbh & co kg
Manufacturer's Name:

Adresse des Herstellers: Talstr. 1-5
Manufacturer's Address: 76593 Gernsbach, Germany

erklärt unter alleiniger Verantwortung, dass das gelieferte Produkt
declares under sole responsibility that the product as originally delivered

Produktname: In-Line-Messverstärker für DMS-Sensoren
Product Name: In-Line Amplifier for Strain Gauge Sensors

Modellnummer(n) (Typ): 9236-Vxxx
Models Number / Type:

Produktoptionen: Diese Erklärung beinhaltet obengenannte Produkte mit allen Optionen
Options *This declaration covers all options of the above product(s)*

mit den folgenden europäischen Richtlinien übereinstimmt und entsprechend das CE-Zeichen trägt:
complies with the requirements of the following applicable European Directives, and carries the CE marking accordingly:

2006/95/EC Elektrische Betriebsmittel zur Verwendung innerhalb bestimmter Spannungsgrenzen
Low Voltage *Electrical Equipment designed for use within certain voltage limits*

2004/108/EC Elektromagnetische Verträglichkeit
EMC *Electromagnetic Compatibility*

Die oben beschriebenen Produkte sind konform mit den Anforderungen der folgenden Dokumente:
The objects of the declaration described above are in conformity with the requirements of the following documents:

Sicherheit: IEC 61010-1:2001 / EN 61010-1:2001 Messkategorie 1 Schutzklasse III
Safety requirements: CAT 1 *Safety class 3*

EMV Störaussendung: IEC/CISPR 11:2003 + A1:2004 + A2:2006 / EN 55011:2007 + A2:2007
EMC Generic emission:

EMV Störfestigkeit: IEC 61326-1:2005 / EN 61326-1:2006 Industrie Bereich
EMC Generic immunity: *Industrial environment*

Ergänzende Informationen: / Additional Information:

Das Produkt wurde in einer typischen Konfiguration getestet. Die Inbetriebnahme ist solange untersagt, bis festgestellt wurde, dass das Endprodukt, in welches unser Erzeugnis eingebaut werden soll, den Bestimmungen der EG-Richtlinien entspricht. Um optimale Störfestigkeit zu erreichen ist das Produkt über geschirmte Leitungen anzuschließen. *Das Produkt benötigt weniger als 50 Watt.

*The product was tested in a typical configuration. The initiation is prohibited until it can be stated that the final product, in which our product shall be installed, corresponds to the definitions of the EC guidelines. In order to reach optimal electromagnetic immunity the device has to be conducted with shielded line. *The product requires less than 50 W.*

Diese Konformitätserklärung betrifft alle nach Ausstellungsdatum ausgelieferten Produkte:

This declaration of conformity applies to above-listed products placed on the EU market after:

Gernsbach 08.05.2009 i.V. Christian Karius
Datum / date Quality Manager

Dieses Dokument ist entsprechend EN ISO/IEC 17050-1:2004 Abs. 6.1g ohne Unterschrift gültig / According EN ISO/IEC 17050 this document is valid without a signature.

burster präzisionsmesstechnik gmbh & co kg · Talstr. 1-5 · D-76593 Gernsbach (Postfach 1432 D-76587 Gernsbach) Tel. 07224/645-0 · Fax 645-88
www.burster.de · www.burster.com · info@burster.de

Sitz der Gesellschaft: HRA 530170 Mannheim · Komplementär: burster präzisionsmesstechnik Verwaltungs-GmbH · Sitz der Gesellschaft: Gernsbach · HRB 530130 Mannheim
Geschäftsführer: Matthias Burster · Prokurist: Edgar Miggler · UST-Identnr.: DE 144 005 098 · Steuernr.: 39454/10503
Dresdner Bank AG Rastatt Kto. 06 307 073 00 BLZ 662 800 53 · Volksbank Baden-Baden* Rastatt eG Kto. 302 082 00 BLZ 662 900 00





Amplifier 9235



9236 in tube housing

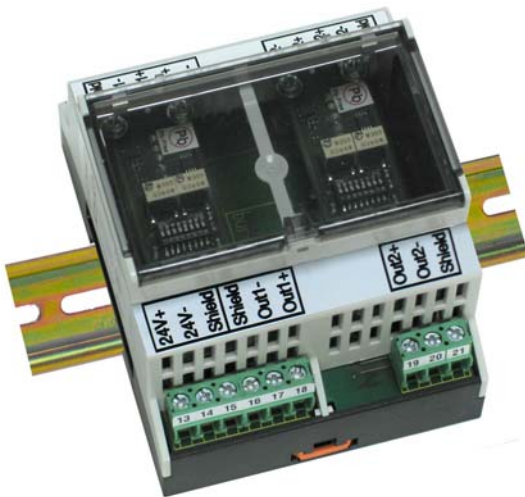

9236 as mounting rail version (2 channels)



9236 as mounting rail version (4 channels)





Warning!

The following instructions must be followed to prevent electric shock and injuries:

- To reduce the danger of fire and electrical shock, rain and other humidity should be avoided.
- To avoid the risk of an electrical shock, please do not open the housing. Repairs and services must be effected only by qualified and well trained personnel.
- This instrument works on 15-30 VAC. Please make sure that the operational voltage of the instrument is equal to the local feeding voltage. Check the power cable prior to start of operation.
- If any parts or fluids should enter the device please take off the power cable immediately. Qualified personnel must check the instrument before you operate it the next time.
- If you do not want to use the device for a longer period of time you should take off the power cable. Always pull on the connector, **not** on the cable.
- Assure a sufficient airflow so that excessive heat inside the device is avoided.
- Do **not** place the instrument on surfaces such as carpets or blankets or near materials such as curtains or wall textiles that could hinder the air circulation.
- Do **not** place the device near sources of heat such as radiators, hot air outlets or at places where it is exposed to direct sunlight, light bulbs, excessive dust, mechanical vibration or impacts
- Keep the device in sufficient distance to other instruments, machines or installations that are the source to magnetic fields.
- Do **not** place heavy objects on the devices.
- If the device is brought in from a cold to a warm room there might be liquid condensing in the interior of the device. Please wait a few hours before you operate the instrument
- The necessary law and safety regulations have to be complied with for every application case. This is valid also for the use of the accessories.
- The measuring amplifier does **not** have an approval for hazardous areas; the device does **not** work with safety barriers connected on the sensor side.



Contents

1. Introduction	13
1.1 Intended use.....	13
1.2 Customer service.....	14
1.2.1 Factory warranty	14
1.2.2 Contact details for technical queries	14
1.2.3 Head office's address	14
2. Preparing for use.....	15
2.1 Unpacking.....	15
2.2 Storage	15
2.3 Power excitation	15
3. 9235 Mounting and Operation	17
3.1 Mounting the 9235.....	17
3.1.1 Terminal assignment 9235.....	17
3.1.2 Mechanical installation of 9235.....	19
3.2 Operation of 9235.....	20
3.2.1 Controls of 9235.....	20
3.2.2 Switching on 9235.....	20
3.2.3 Functional test of 9235.....	20
3.2.4 Sensor excitation by 9235.....	20
3.2.5 Setting the zero point of 9235	20
3.2.6 Setting the sensitivity of 9235	21
3.2.7 Input reference point 9235	21
3.2.8 Cut-off frequency 9235	21

4.	9236 Mounting and Operation	23
4.1	Mounting the 9236	23
4.1.1	Opening the tube housing 9236	23
4.1.2	Terminal assignments 9236	24
4.1.3	Mechanical installation of 9236	27
4.2	Operation of 9236	28
4.2.1	Controls of 9236	28
4.2.2	Switching on 9236	28
4.2.3	Functional test of 9236	28
4.2.4	Sensor excitation by 9236	29
4.2.5	Setting the zero point of 9236	29
4.2.6	Setting sensitivity of 9236	29
4.2.7	Input reference point 9236	31
4.2.8	Cut-off frequency 9236	31
4.2.9	Output voltage 9236	31
5.	Calibrate	33
5.1	Calibrating with a physical magnitude	33
5.2	Calibrating with a strain gauge simulator	34
5.3	Calibrating with a precision voltage source	35
5.4	Shunt-Calibration	36
6.	Cleaning and maintenance	39
6.1	Cleaning	39
6.2	Maintenance	39
7.	Technical data of 9235	41
8.	Technical data of 9236	43

1. Introduction

In practical applications it oftentimes becomes necessary to transform the measuring signal of a sensor in the most simple way to a standard signal in the sensor's nearby environment. This makes a transfer of the measurement values to the central metrology department or the system's control easily possible over larger distances with low losses.

The In-Line-Amplifier offers this function in an ideal way as it is placed in the connecting cable. Based on its compact and sturdy construction and its low weight it can be used in almost all applications. The IP67 version of the 9236 (tube housing) is designed mainly for use outside the switchboard at almost all places and is configured firmly to one sensor. The tube housing is made of aluminum, very stable and offers good protection in rough, environment.

Users who want to integrate the amplifier on a present board or in another housing can choose it as an open element with connecting clamps instead of plug contacts.

The In-Line-Amplifier itself is operated at 15 V DC to 30 V DC. From this it generates a stable supply voltage for the sensor. The measuring signals of the sensor that usually range from 0 ... 5 mV up to 0 ... 10 mV for bridge circuits with strain gauges are amplified to analog 0 ... 10 V. The characteristics of the sensor are preset roughly by the DIP-switches. The fine tuning of the zero point and amplifier setting is done with multirange trimmers. Short circuit proof sensor supply and protection against polarity reversal for the amplifier support an extra of security at installation. The mounting of the amplifier – if necessary at all – is realized for the IP67 version of the 9236 (tube housing) by clamping or gluing of the housing whereas the open board has mounting holes for screws of type M2.5. The limit frequency of the amplifier is >1kHz, its weight <100 g.

1.1 Intended use

The device serves for signal processing of strain gage sensors.

Every other use is declared as not appropriate.

The device is **not intended to be used as a safety device**. Its use under safety-critical conditions is prohibited.

The amplifier is **not** suitable for use in medical equipment. Its use in medical equipment is therefore prohibited.

The measurement amplifier does **not** have an approval for hazardous areas; the device does **not** work with safety barriers connected on the sensor side.

The safe and sound use of this device does imply an appropriate transport, handling, storage, setup and mounting as well as careful operation and maintenance.

1.2 Customer service

For repair queries

Please contact us:

Telephone 0049 (0)7224-645-53

Please have your serial number ready for such enquiries. This information is essential in order to find out the technical status of the device and hence provide help quickly.

The serial number is shown on the type plate.

1.2.1 Factory warranty

burster präzisionsmesstechnik gmbh & co kg provides a manufacturer's warranty for a period of 24 months after delivery.

Any repairs required during this time will be made without charge.

Damage caused by improper use of the device is not covered by the warranty.

If the device needs to be returned for repairs, please note the following requirements for packing and shipping:

- If you have a problem with the device, please attach a note to the case summarizing the fault.
- The amplifier must be shipped only in its original packaging provided by us or in a container capable of providing an equivalent degree of protection.

The technical data can change at any time without notification. We also state explicitly that we do not accept liability for consequential damage.

1.2.2 Contact details for technical queries

If you have any questions relating to the amplifier, please contact your representative or go directly to burster präzisionsmesstechnik gmbh & co. kg.

1.2.3 Head office's address

burster präzisionsmesstechnik gmbh & co kg
Talstraße 1 – 5
D-76593 Gernsbach
Telephone: 0049 (0)7224 – 645 – 0
Fax: 0049 (0)7224 – 645 – 88
E-Mail: info@burster.de

2. Preparing for use

Note:

If any transport damage is visible, the device must not be switched on **under any circumstances**.

Note:

The amplifier must be shipped only in its original packaging provided by us or in a container capable of providing an equivalent degree of protection.

2.1 Unpacking

- Unpack the unit carefully.

If you suspect that the unit has been damaged during shipping, notify the delivery company within 72 hours. The packaging should be retained for examination by a representative of the manufacturer and/or the delivery company.

- Verify that all items are present.

The delivery includes the following parts as standard:

- Amplifier
- Manual

- Inspect the instrument carefully for damage.

2.2 Storage

- The amplifier must be stored under the following conditions only:
 - dry
 - no condensation
 - temperature between 0 °C and 60 °C

2.3 Power excitation

Supply voltage: 15-30 V DC unregulated

Current consumption: ≤ 20 mA per channel

3. 9235 Mounting and Operation

3.1 Mounting the 9235

- Locate the sensor and the measuring instrument outside the range of high-energy equipment.

This includes transformers, motors, contactors, frequency converters and so forth. Otherwise the electromagnetic fields from such equipment will act with their full effect on the measuring chain, causing incorrect measurements.
- Lay the measuring lines separately from high-power cables.

If the measuring lines are laid parallel to such cables, interference will be coupled in inductively and capacitively.

In some cases it will be helpful to place an extra shield as additional protection over the measuring cable, or to lay it in a metal tube or pipe.

Ensure that the measurement cables are kept at least 0.5 m from power lines.

Twist the power and control cables (15 twists per meter).

Note:

At mounting on conductive ground, the cable shield can be linked to the housing additionally. Check the potential bonding.

3.1.1 Terminal assignment 9235

Version with D-Submin Connectors

Note:

Use only shielded measurement leads. The cable shield is usually not connected to the sensor housing on burster sensors. The shield of the cable should be connected to the plug housing which is electrically connected with the amplifier housing. The cable shield is usually connected via the supply line or the process instruments to protective ground.

The shield may also be connected with pin 3 from socket and bushing. As a result, the shield would be on the function ground of model 9235. The potential bondings of the electronics connected in the measurement chain have to be respected.

Note:

If the shield plug is connected with sensor housing, let it be disconnected with the plug housing.

Socket (sensor's side)		Connector	
1 +	SENSOR EXCITATION	2 +	SUPPLY VOLTAGE
3	SHIELD (Optional)	3	NC
5 -	SENSOR EXCITATION	5	SUPPLY GROUND
6 +	SIGNAL INPUT	7 □	OUTPUT VOLTAGE
9 -	SIGNAL INPUT	9	OUTPUT GROUND

Note:

The pins 3, 5 are connected with each other.

Note:

Please keep the protection caps for transport use.

Note:

The connections of sensor socket pin 3 (shield) and pin 5 (sensor excitation) as well as the supply resp. process electronics pin 3 (shield), pin 5 (supply ground) and pin 9 (output ground) are all linked with each other.

Version with clamps

Note:

Use only shielded measurement cables. The cable shield of burster sensors is usually not connected to the sensor housing. If you mount the amplifier to a conductive housing, it is recommended to link the shield directly to the housing. The housing is then usually connected via the supply or process instrumentation to protective ground. Optionally, the cable shields can be connected to the clamps 3 of socket and plug. The shields are then linked to functional ground of model 9235. The potential bondings of the process instruments in the measuring chain have to be respected.

Clamp "Sensor"	Clamps without description
1 + SENSOR EXCITATION	1 + SUPPLY VOLTAGE
2 - SENSOR EXCITATION	2 SUPPLY GROUND
3 NC	3 NC
4 + SIGNAL INPUT	4 ± OUTPUT VOLTAGE
5 - SIGNAL INPUT	5 OUTPUT GROUND

Note:

The pins 2 and 3 are connected to each other.

Note:

The connections of sensor connection socket clamp 3 (shield) and clamp 2 (sensor excitation) as well as the supply resp. process electronics pin 3 (shield), clamp 2 (supply ground) and clamp 5 (output ground) are connected with each other.

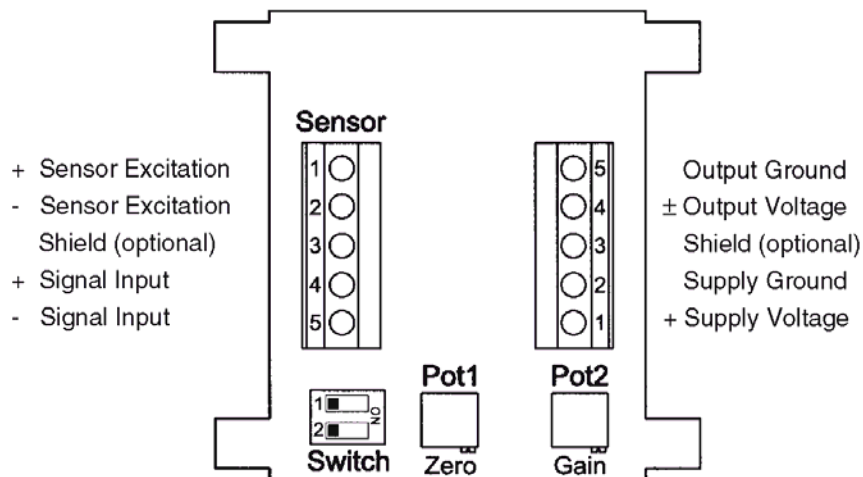

Figure 1: Pin 1 of the clamps is marked. View point is on the adaptive opening of the clamps: pin 1 is on the left side.

Grounding and potential bonding

Measuring inputs and outputs are neither divided on potential between one and the other nor on the supply voltage. The housing is insulated from the electronic

- Contact the housing only via the connector's housings.
- Recognize the potential bonding of the sensor, cable shield and process electronics.

3.1.2 Mechanical installation of 9235

Board without housing

The board version features 4 borings for screws M2.5 in a pitch of 40 mm x 37.2 mm.

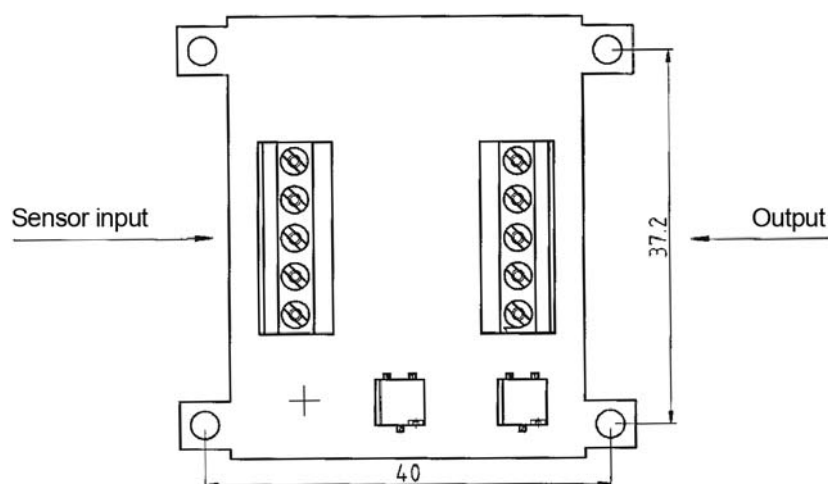

3.2 Operation of 9235

3.2.1 Controls of 9235

Zero point and amplification fine adjustment

Two borings can be found on the side panel. Through this borings you will reach the potentiometer for fine tuning of zero point and amplification.

Sensitivity

Through the boring in the top the 9235 you may reach the switch for setting of the nominal sensitivity.

3.2.2 Switching on 9235

- Apply the excitation voltage.

The device is switched on by applying the supply voltage.

The warm-up takes approx. 10 min.

If the supply voltage is switched off during a running measurement the amplifier would continue the measurement after the energy is switched back on.

3.2.3 Functional test of 9235

Note:

The 9235 does not have optical or acoustical signal generator.

- Switch on the amplifier without having sensors or instruments connected
- Check the voltage on +SUPPLY VOLTAGE.

The factory setting of the 9235 is 2.5 V.

3.2.4 Sensor excitation by 9235

The excitation voltage of sensors is asymmetrical, ground related and short-circuit proof.

The maximum current is approx. 10 mA.

3.2.5 Setting the zero point of 9235

- Turn the potentiometer at the side panel of 9235.

The screw driver blades' width must not be greater 1 mm.

The setup range of the potentiometer is approx. 25 % of the measuring range.

3.2.6 Setting the sensitivity of 9235

- Choose the nominal sensitivity using the DIP switches

Nominal sensitivity mV/V	Switch 1 above	Switch 2 below	Range of sensitivity mV/V
1	closed (right position)	closed (right position)	0.8 ... 1.3
1.5	opened (left position)	closed (right position)	1.2 ... 2.0
2	opened (left position)	opened (left position)	1.6 ... 2.6

- Make the fine tuning of amplification by setting the potentiometer at the side panel of the amplifier.

The screw driver blades' width must not be greater 1 mm.

The setup range of the potentiometer is approx. $\pm 23\%$ of the measuring range.

3.2.7 Input reference point 9235

The input amplifier is designed as a differential amplifier. This means that the negative signal input is not linked to ground. (If a ground linkage is needed it would need to be done externally. This is of importance for calibration of voltage sources, for example)

3.2.8 Cut-off frequency 9235

The cut-off frequency of the amplifier is >1 kHz.



4. 9236 Mounting and Operation

4.1 Mounting the 9236

- Locate the sensor and the measuring instrument outside the range of high-energy equipment.
This includes transformers, motors, contactors, frequency converters and so forth. Otherwise the electromagnetic fields from such equipment will act with their full effect on the measuring chain, causing incorrect measurements.

- Lay the measuring lines separately from high-power cables.

If the measuring lines are laid parallel to such cables, interference will be coupled in inductively and capacitively.

In some cases it will be helpful to place an extra shield as additional protection over the measuring cable, or to lay it in a metal tube or pipe.

Ensure that the measurement cables are kept at least 0.5 m from power lines.

Twist the power and control cables (15 twists per meter).

4.1.1 Opening the tube housing 9236



Risk of damage.

Before opening the tube housing always undo both PG cable glands.

Before opening or closing the tube housing, isolate the 9236 from the power supply.

With the version of the 9236 in the tube housing, all controls and connections are located inside the housing.

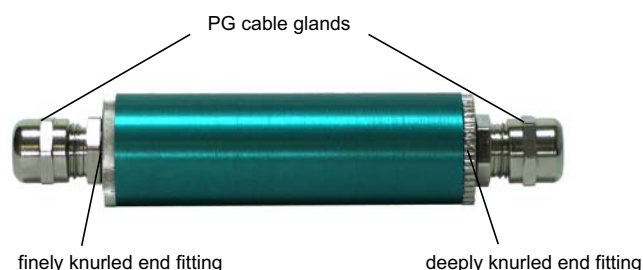

Figure 2: One of the end fittings has deep knurling

How to open the tube housing

- Undo the PG cable glands at both ends of the tube housing.
By doing this you reduce the risk of damaging the connecting cable when opening the housing.
- Unscrew the deeply knurled end fitting from the housing.
The end fittings on the housing are connected to the rest of the housing via a threaded fitting.
- Now carefully slide the end fitting away from the housing.
- Unscrew the housing from the finely knurled end fitting.
- Slide the housing away from the circuit board.

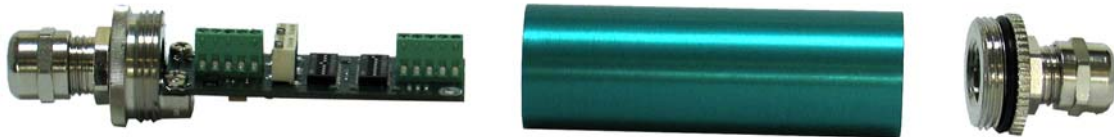

Figure 3: Once the housing is unscrewed from the end fittings, the circuit board is exposed.

4.1.2 Terminal assignments 9236

Connect the 9236 exclusively to power supplies that are equipped with a safety transformer in accordance to EN 61558.

Note:

Devices connected to the input and output circuits that are connected to the 9236's signal lines must also be fitted with a safety transformer to EN 61558.

Note:

Always use shielded measurement cables. With burster sensors, the cable shield is not usually connected to the sensor housing. Place the connecting cable's shield on the connector shells, which are electroconductively connected to the measuring amplifier housing. As a rule, the cable shield should be connected to (protective) ground via the power supply lead and/or subsequent evaluation electronics.

Alternatively, you can connect the cable shield. If you do this, the shield is connected to the functional ground (FE) of the 9236. When doing this, take into account the ground connections of the input-side and output-side electronics.

Note:

If the shield connector connects to the sensor housing then it must not be connected to the plug connector.

Functional ground

With the IP67 version, the cable shield is always placed on the tube housing.

- Ensure a proper ground connection when installing on a conductive material.

The measurement inputs and outputs are not electrically isolated from each other or from the supply voltage. The housing is isolated from the electronics.

- Electrical connections with the housing should only be made via the plug connector housings.
- Ensure proper ground connections for the sensor, cable shield and subsequent electronics.

Terminal assignment for circuit board and version in tube housing

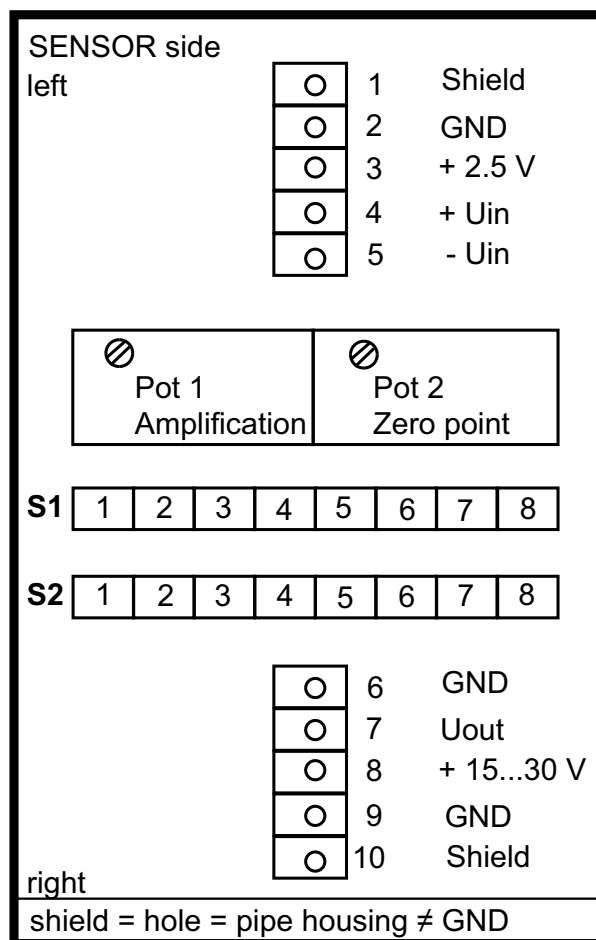

Terminal assignment for mounting rail version, 2-channel

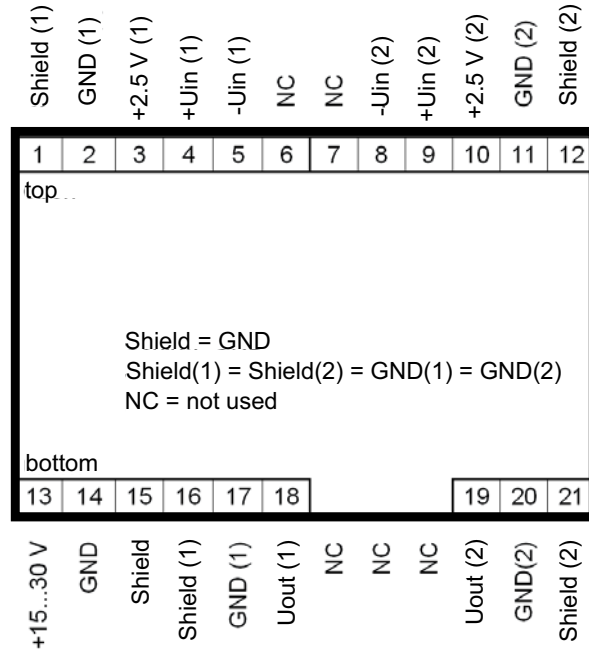

Terminal assignment for mounting rail version, 3 or 4-channel

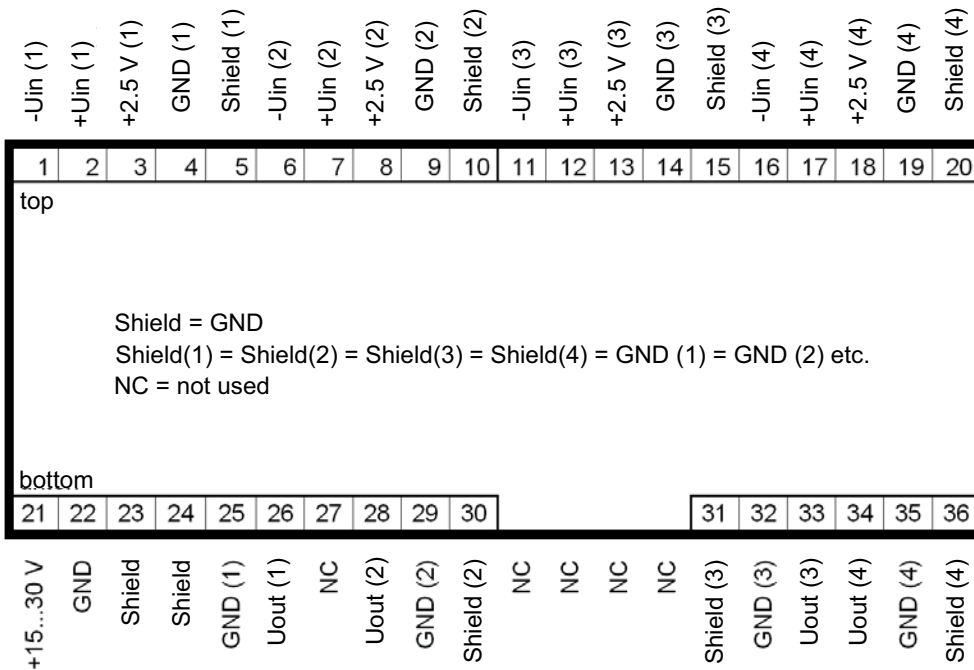

4.1.3 Mechanical installation of 9236

Circuit board without housing

The circuit board version has four pre-drilled holes for M2.5 bolts in a grid of 14.6 x 53.6 mm.

Tube housing

- Secure this version of the 9236 using conventional screw clips or cable ties.

The **tube housing** provides **IP67** protection. The module is therefore protected against ingress of dust and water.

Mounting rail housing

Secure the measuring amplifier to an EN mounting rail.

4.2 Operation of 9236

4.2.1 Controls of 9236

The 9236 has one circuit board for each channel. This circuit board contains all the controls that are required for operation of the 9236.

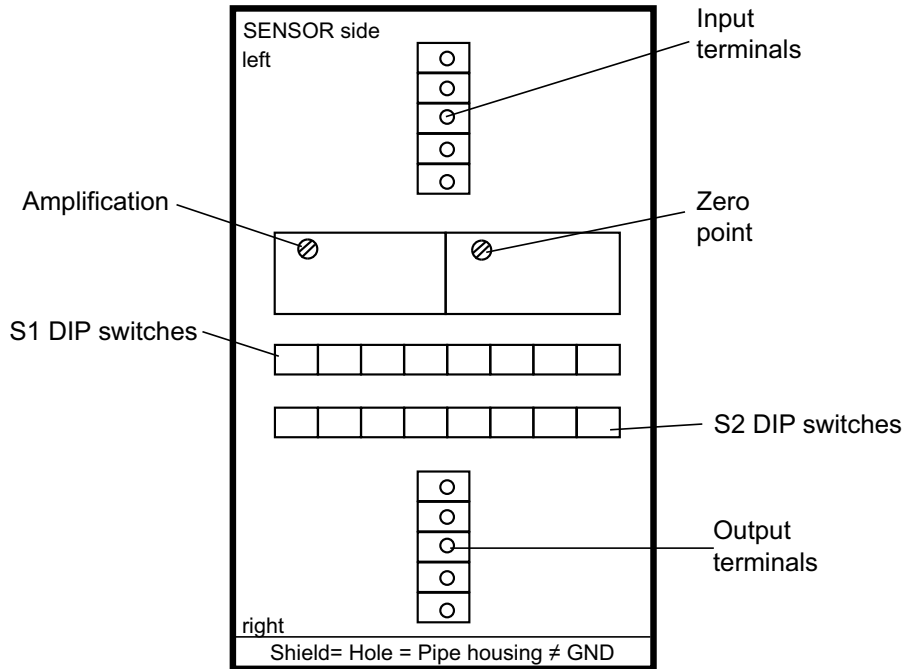

4.2.2 Switching on 9236

Before switching on the 9236, you have to connect all sensors and appliances.

- Connect the device to the excitation voltage.

The device is switched on by applying the excitation voltage.

Warm-up period takes approx. 10 min.

If the excitation voltage is switched off during a running measurement the amplifier would continue the measurement after the energy is switched back on.

4.2.3 Functional test of 9236

Note:

The 9236 does not have an optical or acoustic signal generator.

- Switch on the 9236 without sensors or devices connected to it.
- Check the sensor excitation voltage.

The 9236 is factory set to 2.5 V.

4.2.4 Sensor excitation by 9236

The sensor excitation voltage is asymmetrical, ground related and short-circuit proof.

The maximum current is approx. 10 mA.

4.2.5 Setting the zero point of 9236

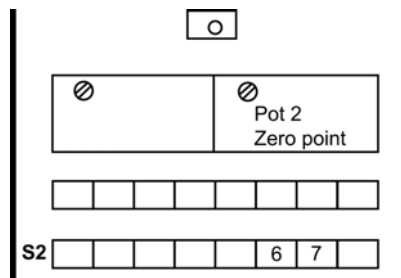

- Set the zero point by turning potentiometer 2 (zero point).

The potentiometer's adjustment range is $\pm 25\%$ of the measuring range, switchable to $\pm 5\%$.

This adjustment range is determined via the two DIP switches S2-6 and S2-7. If both switches are in the "OFF" position, the adjustment range is at its smallest. If both switches are in the "ON" position, the adjustment range is at its largest. All switch positions can be combined as required; this may result in asymmetrical adjustment ranges.

4.2.6 Setting sensitivity of 9236

The 9236 is factory set to the default sensitivity of 1.5 mV/V. On the 9236, the DIP switches S1-1 to S1-8 and S2-1 to S2-5 are used to set a different sensitivity.

Switches S2-6 to S2-8 are used for a different purpose.

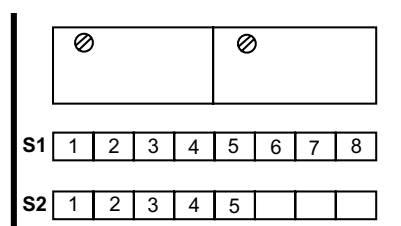

Figure 4: The S1 DIP switches and some of the S2 DIP switches determine the sensitivity.



Caution!

Risk of damage to components.

Before opening or closing the housing, isolate the 9236 from the power supply.

How to set the sensitivity of the 9236:

- Disconnect the 9236 from the power supply.
- Open the housing of the 9236, if applicable.
- Set DIP switches S1-1 to S1-8 and S2-1 to S2-5 to the "OFF" position.
- Look up the appropriate sensitivity in the following table.

Number	Sensitivity (mV/V)
S1-1	0.5
S1-2	0.75
S1-3	1
S1-4	1.25
S1-5	1.5
S1-6	2
S1-7	2.5
S1-8	3
S2-1	5
S2-2	10
S2-3	15
S2-4	20
S2-5	30

- Set the associated DIP switch to the "ON" position.

After you have set the sensitivity on the 9236, you can now finely adjust it.

- For fine adjustment, connect the 9236 to the power supply.

- Turn potentiometer 1 (amplification).

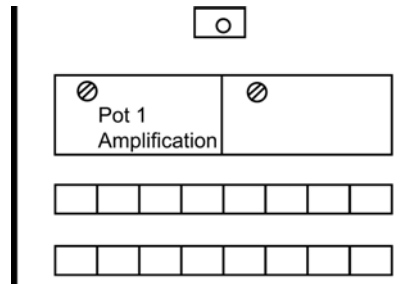

The adjustment range of this potentiometer is approx. $\pm 20\%$ of the nominal amplification.

- Disconnect the 9236 from the power supply again.
- Close the housing of the 9236.

4.2.7 Input reference point 9236

The input amplifier is designed as a high impedance differential amplifier. This means that the negative signal input is not linked to ground. (If a ground linkage is needed it would need to be done externally. This is of importance for calibration of voltage sources, for example)

4.2.8 Cut-off frequency 9236

The cut-off frequency is ≥ 1 kHz (-3 dB).

4.2.9 Output voltage 9236

The 9236 offers you two different ranges for the output voltage (± 5 V or ± 10 V). The standard factory setting is the ± 10 V range.

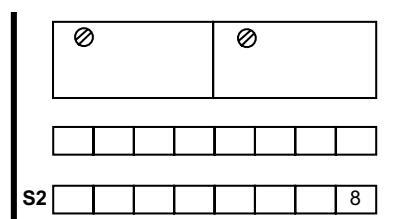

Figure 5: The DIP switch S2-8 is used to set the output voltage.

How to set the output voltage:

If you want to set the output voltage to ± 5 V:

- Set DIP switch S2-8 to the "OFF" position.

If you want to set the output voltage to ± 10 V:

- Set DIP switch S2-8 to the "ON" position.



5. Calibrate

The amplifier should be tested after approximately 2-3 years by the manufacturer. We extend this interval gladly, if the instrumentation characteristics are not fully used.

Please contact us.

In principle there are two various methods you can use to calibrate the amplifier.

After adjustment you must check the device's settings.

5.1 Calibrating with a physical magnitude

Function

The sensor is subjected to a known physical magnitude. The calibration is carried out in this way over the entire measuring chain, consisting of the sensor and display device or amplifier.

Calibration

- Remove any load from the sensor.
- Adjust the zero point.
- Load the sensor with a known reference weight.
- Adjust the reference scale value.

If desired, we can prepare factory calibration or recalibration certificates for the sensor or for the entire measuring chain.

These measurements are carried out at the factory on weight measurement installations.

Please contact us.

5.2 Calibrating with a strain gauge simulator

If you cannot specifically load strain gauge sensors, for example because no suitable weights are available, you will need to simulate the appropriate measuring signal using a strain gauge simulator.

Because strain gauge sensors often have "curved" characteristic values (referred to as nominal characteristics), usually a simulator cannot replicate them exactly. In this case, set the simulator to the next lower characteristic value. You will then need to calculate the corresponding amplifier voltage.

Calibration

- Remove any load from the connected sensor.
- Adjust the zero point.
- Disconnect the sensor from the amplifier.
- Connect the amplifier to the strain gauge simulator.

Strain gauge sensors usually have "curved" characteristic values that you cannot directly set on the simulator.

Therefore, proceed as follows:

- Set the simulator to the next lower characteristic value.
- Now calculate the amplifier output voltage with simulator connected (U_{asim}).

To calculate U_{asim} you need these values:

- U_a : Required amplifier output voltage when sensor is subject to nominal load.
- K_{sim} : Characteristic value set on the simulator.
- C : Characteristic value of the sensor to be simulated. Output signal (characteristic value).

You can now calculate U_{asim} using this formula:

$$U_{\text{asim}} = U_a \cdot \frac{K_{\text{sim}}}{C}$$

- Set the calculated value of U_{asim} at the amplifier output.
- Adjust the reference value.

Example

A type 8438-100 kN sensor is to be simulated. According to the test certificate, this sensor has a characteristic value (C) of 1.678 mV/V.

The required amplifier output voltage (U_a) should be 10 V.

A burster type 9405 strain gauge simulator is used for the simulation. This simulator does not enable you to set the exact characteristic value. Therefore the next lower value of 1.5 mV/V is selected. This is the characteristic value K_{sim} .

If this value is now used in the formula, it produces the amplifier output voltage with simulator connected (U_{asim}):

$$U_{asim} = U_a \cdot \frac{K_{sim}}{C} = 10 \text{ V} \cdot \frac{1.5 \text{ mV/V}}{1.678 \text{ mV/V}} = 8.939 \text{ V}$$

5.3 Calibrating with a precision voltage source

You can always use this calibration method if you use a sensor whose output signal is a voltage. In this case you replace the sensor with a precision voltage source.

You can only use this method to check that the amplifier is functioning.

Note:

The supply voltage of full-bridge strain gauge sensors affects the result of the measurement. It is possible that the actual supply voltage will vary slightly from the rated supply voltage. If you want to verify the proper function of the instrumentation amplifier using a voltage source, you must measure the sensor supply voltage with a precision digital voltmeter, and then calculate the calibration voltage.

Calibration

- Remove any load from the connected sensor.
- Adjust the zero point.
- Disconnect the sensor from the amplifier.
- Connect the amplifier to the precision voltage source.
- Set the precision voltage source to a voltage that corresponds to the sensor's signal when subject to nominal load.
- Adjust the reference value.

5.4 Shunt-Calibration

You are able to a calibration shunt between negative input terminals and the negative sensor excitation terminal. For this method of calibration, the sensor has to be connected to the amplifier.

Such a shunt is generally used to tune a strain-gauge bridge according to requirements. If the value of the calibration shunt and the tuning step generated by it are known, then this technique can be used to calibrate the measuring chain.

The specification sheets of most strain-gauge sensors generally state the value of the calibration resistor and the related tuning step as a percentage of the rated characteristic value or directly in mV/V.

Note:

You can use this calibration method to calibrate the measuring chain and check the electrical function of the sensor. It is **not** possible to verify the measurement properties of the sensor.

Calibrate

- Remove any load from the connected sensor.
- Adjust the zero point.
- Connect the shunt between the negative input terminal and the negative sensor excitation terminal on the amplifier.

As a result of connecting the shunt, the sensor's strain gauge full bridge is unbalanced by a certain amount, the calibration offset.

This depends on the sensor and the shunt (resistor) used. Since a particular shunt causes a particular calibration offset, you can calibrate the measuring chain in this way.

You can find the size of the shunt and the associated calibration offset in the sensor's data sheet.

- Now adjust the amplifier's output voltage.

Example

A measuring chain consisting of an amplifier and a strain gauge sensor (350 Ω) have to be calibrated with a calibration offset. The sensor's nominal characteristic value is 1.5 mV/V, the sensor excitation voltage is 2.5 V. The required amplifier output voltage (U_a) is 10 V.

On the sensor's test certificate, the shunt (calibration resistance) is specified as 100 kΩ and the associated calibration offset is 1.2 mV/V.

Given	Strain gauge sensor	350	Ω
	Characteristic	1,5	mV/V
	Calibration step	1,2	mV/V
	Calibration shunt resistor	100	kΩ
	Sensor excitation voltage	2,5	V
	required amplifier output voltage U_a	10	V

Wanted The amplifier output voltage U_{aKAL} to be set if a 100 kΩ calibration shunt has been connected.

Step 1 Calculate and set the gain “v” for 1.5 mV/V as described in the example in Chapter 3 and 4.

Step 2 Calculate the step in the input signal caused by the shunt

$$U_{eKAL} = \text{Tuning step} \times \text{excitation voltage}$$

In this example 3,000 mV.

Step 3 Calculate the amplifier output voltage U_{aKAL} (to be fine-adjusted) when U_{eKAL} (= 3.000 mV in this example) is applied instead of the input voltage U_e supplied by the sensor (3.750 mV in this example) :

$$U_{aKAL} = \frac{U_a \cdot U_{eKAL}}{U_e} = \frac{10 \text{ V} \cdot 0,003 \text{ V}}{0,00375 \text{ V}} = 8,000 \text{ V}$$

U_e = Output of the sensor x excitation voltage

U_a = Output of the amplifier with U_e

In this example, 8.000 V are to be set at the amplifier output.

6. Cleaning and maintenance

6.1 Cleaning

- Use only cleaning agents that are free from organic or concentrated inorganic solvents.
A damp cloth is sufficient.

6.2 Maintenance

The 9243 does not require any maintenance by the user.

Any required repairs must be performed only by the manufacturer.

7. Technical data of 9235

Connectable sensors	strain gauge sensors
Bridge resistance:	Strain gauge full bridge from 350 Ω up to 5 kΩ
Connection technology:	4-wire (no sense lines) No function with safety barriers!
Sensor excitation voltage	2.5 V ±<0.1 % short-circuit proof, not adjustable
Excitation current:	<20 mA
Configurable sensitivity:	1 / 1.5 / 2 mV/V
Default setting:	1,5 mV/V
General amplifier values	
Amplification	(905 / 604 / 453)*(3.3 ... 5.5) Overlapping adjustment ranges
Remaining waviness:	<5 mV _{eff}
Noise:	<2 μV _{eff} related to input
Zero point::	Adjustment range approx. 25 % of meas. range
Temperature coefficient:	<100 ppm / K (so OK?)
Zero point drift::	<0.4 μV / K typ.
Excitation voltage:	15 ... 24 ... 30 V Power input approx. 15 mA (with sensor 350 Ω) Protected against polarity reversal
Output:	Voltage output 0 ... ±10 V Inner resistance 470 Ω Range: approx. ±10.4 V without load
Cut-off frequency:	approx. 1 kHz (-3 db)
Protection class:	IP20
Dimensions (L x W x D):	approx. 62 x 55 x 16 mm incl. plug
Weight:	<70 g (with housing)
Connection:	D-Sub / terminals
Operating temperature range:	0 ... 60 °C
Humidity:	10 ... 80 %, no condensation

No potential division between measurement circle and supply



8. Technical data of 9236

Connectable sensors	Strain gauges
Bridge resistance:	Strain gauge full bridge from 350 Ω up to 5 k Ω
Connection technology:	4-wire No function with safety barriers!
Sensor excitation:	2.5 V
Excitation current:	10 mA
Configurable sensitivity:	0.5 mV/V ... 30 mV/V
Default setting:	1.5 mV/V
Analog output	
Output voltage, selectable:	0 ... ± 5 V / 0 ... ± 10 V (default) selectable
Output impedance:	440 Ω
General amplifier values	
Error of measurement:	0.1 % F.S.
Zero point:	$\pm 25/5\%$ (default) of measurement range selectable
Temperature coefficient:	<100 ppm/K
Zero drift:	<0.4 μ V/K
Auxiliary power:	15 ... 30 V DC
Current consumption:	20 mA / 1 channel
Power consumption:	approx. 0.3 VA
Cut-off frequency:	≥ 1 kHz
Range of operating temperature:	0 ... 60 $^{\circ}$ C
Humidity:	10 ... 80 %, no condensation

Model 9235/36

Multichannel amplifier



Housing IP67	
Kind of housing:	Tube housing
Connection:	via PG7 at screw terminals
Dimensions:	120 x 25 mm
Material:	Aluminum
Protection class:	IP67
Weight:	150 g
Housing IP20 2-4 channel	
Kind of housing	Mounting rail housing
Connection:	at screw terminals
Dimensions (H x D x W):	90 x 63 x 108 mm
Material:	Plastic
Protection class:	IP20
Weight:	150 g
Open board	
Connection:	at screw terminals
Dimensions (L x W x D):	65 x 19 x 15 mm
Mounting:	4 holes for screws M2,5 in Grid 14.6 x 53.6 mm
Weight:	50 g