

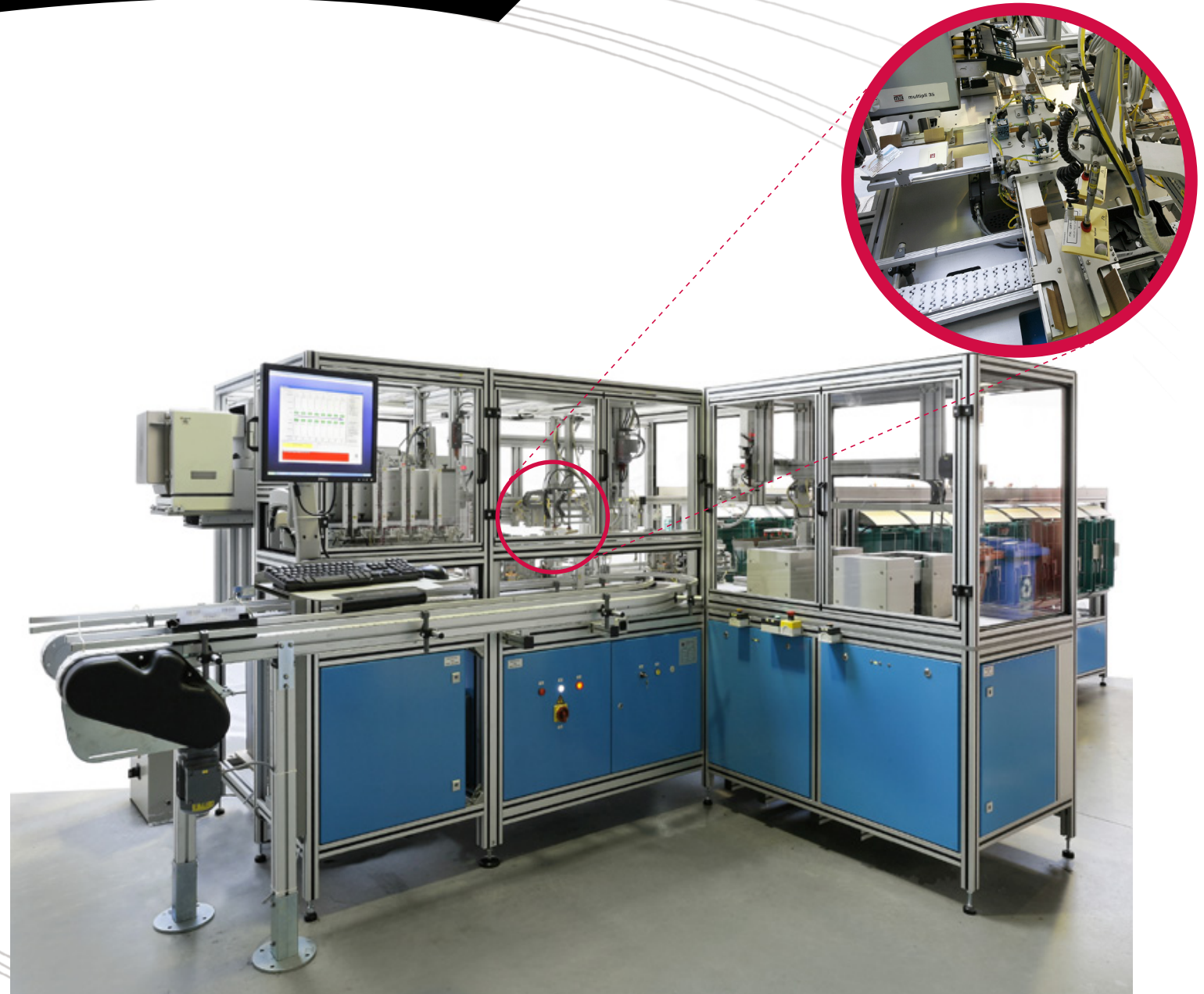

Automation & Robotics

Dispatch Packaging Unit for Prescription Lenses

The Dispatch Packaging Unit for Prescription Lenses is a large scale production machine which gathers both prescription lens envelopes (right and left), a delivery note, ID card, and cleaning clothe along with other accessories; and places them into a larger dispatch envelope. Optional is the automatic sorting between different destinations to reduce and optimize shipping times and costs, while the completely automatic packaging prevents any mispackaging. With the capacity of the machine up to 300 jobs per hour (depending on the materials loaded), the machine can be installed behind the Automatic Packaging Unit for Prescription Lenses



Main Features

Technical Specifications

Benefits

Options

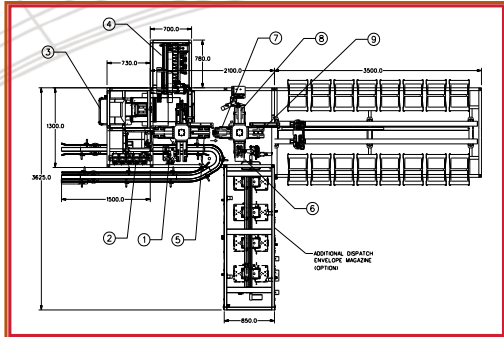

I. Carousel A : preparing contents of dispatch envelope

The 4 stations are :

1. Loading station of packaged RX-lenses
2. Optional :
 - printing and placing of lens ID card (5 magazines)
 - anti-slip film integration (1 magazine)
3. Printing of delivery note
4. Optional :
 - cleaning clothes integration (5 magazines)
 - lens advertisement/booklet integration (4 magazines)
5. Introduction of the total gripper contents into the dispatch envelope

II. Carousel B : for the dispatch envelope manipulation

The 4 stations are :

6. Loading station of dispatch envelope
- Optional :
 - 2 to 4 additional dispatch envelope magazines
7. Opening station of dispatch envelope and introduction of its contents
8. Dispatch envelope sealing station
9. Unloading station dispatch envelope

III. Optional distribution : sorting of the dispatch envelopes into 16 or more different tour boxes (E)

Type : MSEVP

The sale of all of Automation & Robotics products is subject to the company's applicable Warranty and Limitations of Warranty and to the company's Standard Terms and Conditions of Sale.

Ranges :

- FOR LENSES - SEALED ENVELOPES
Dimensions : 80 x 80 mm => 95 x 95 mm
- DISPATCH ENVELOPES WITH WINDOW
Dimensions : 152 mm x 290 mm
- DELIVERY NOTES:
DIN A4 (folded in 3) OR DIN A5 (folded in 2)
Up to 3 different types of delivery notes

Printing :

- Printing and folding of delivey notes
Choice between different printing layouts
- Printing of lens ID cards

Closing of dispatch envelope:

Automatic sealing of dispatch envelope
In standard : manual sealing station

Distributor : pre-sorting into 16 or more tour boxes

Boxes : boxes for special carrier service

Capacity : up to 300 jobs/hour

- Fully automatic machine
- Zero mispackaging
- Correspondance between lens envelope, delivery note, marketing materials and dispatch envelopes
- Large printing options (different printing lay-outs)
- Possibility to print a lens Ident-card
- Connection with the main computer
- Large packaging capacity
- Pre-sorting
- Tour selection menu
- Counting of lenses per tour box
- Automatic presentation of an empty tour box while the full one is taken off by the operator
- Customized software
- Statistics
- Interactive dialog and diagnostics
- Multi lingual menus
- Remote maintenance

- Printing and dispensing of lens Ident-Card
- Dispensing of anti-slip film (max. 1 magazine)
- Possibility of several dispatch envelope magazines (maximum 3 additional)
- 5 wipers magazines
- 4 booklet magazines
- Possibility to have 1 or 2 rows of 16 tour boxes

Parc industriel de Lambermont
Rue des Ormes 111
B-4800 Verviers - Belgium

Tél.: +32 (0)87 322 323
Fax: +32 (0)87 310 406
e-mail: aut-rob@ar.be

T.V.A.: BE 0423.637.107
R.P.M.: Verviers
www.ar.be



Automation & Robotics