



English



User Manual

UPSI-IP-2 Series

UPS SYSTEM
IP65 / 67



Legend of used symbols

Symbol	Description
	Attention! Important hazard warning.
	Do not dispose of in the domestic waste.
	Warning of electrical voltage.

Revision Directory

Date	Change
25.05.2021 Revision 0-1	Initial version
19.11.2021 Revision 1-0	Release version
16.12.2021 Revision 1-1	Chapter B2, C and F1 updated
11.02.2022 Revision 1-2	Chapter B4 included
22.02.2023 Revision 1-3	Chapter B4 Software description updated 5pole USB plug changed into 8pole multifunctional interface



A Brief specification

A1 Overview table

VERSION	INPUT VOLTAGE	OUTPUT VOLTAGE	OUTPUT CURRENT	BATTERY TECHNOLOGY
UPSI-1208IP-23U	12VDC	12...11.35 VDC (depending on load)	8 A nom.	EDLC (Supercap): BP-SUC-10066
UPSI-1208IP-23UW	7...36VDC			
UPSI-2406IP-24U	24VDC	24...23.3 VDC (depending on load)	6 A nom.	EDLC (Supercap): BP-SUC-16090
UPSI-2406IP-24UW	8...36VDC		5.4 A nom.*	
UPSI-2406IP-26U	24VDC		6 A nom.	LiFePO4: BP-LFP-1375
UPSI-2406IP-26UW	8...36VDC	4.6 A nom.*		

*UPSI-2406IP-24UW: 5.4...6 A without charging mode (SOC = 100%), see derating curve on page 8

*UPSI-2406IP-26UW: 4.6...6 A without charging mode (SOC = 100%), see derating curve on page 10



A2 Brief specification UPSI-1208IP-23U / UPSI-1208P-23UW

UPSI-1208IP-23U / 1208IP-23UW

12V/8A

- ✓ **Outdoor DC UPS for extreme environments in robust aluminium housing with IP65/67 protection**
- ✓ **Already integrated Supercaps as energy storage (9.8 kJ)**
- ✓ **Temperature range -20...+70°C**
- ✓ **Based on UPSI-1208/-2406 technology incl. features**
- ✓ **Preassembled mounting bracket**
- ✓ **Pressure compensation element to prevent condensation inside**
- ✓ **External multifunctional interface**
- ✓ **Power and USB cable set with 3 m length each inclusive**
- ✓ **-23UW with additional wide range input**



TECHNICAL DATA	UPSI-1208IP-23U	UPSI-1208IP-23UW
Input voltage*	12 VDC (11.5...16VDC)	7...36 VDC
Input current	9.2 A max.	~14 A max. (depending on input voltage and load)
Output voltage*	12...11.35 VDC (depending on load)	
Output current	8 A nominal	
Capacitive load	3000 µF (at start)	
Charging method	CC/CV/CP	
Protection	Reverse polarity at input, Overcurrent protection at output, Short circuit protection at output	Overtemperature protection (DC/DC-converter), Over current protection at output, Short circuit protection at output
Interface	USB, HID UPS	
Battery technology	EDLC (Supercaps): 9.8 kJ (6.6 kJ useful) / 2.72 Wh (1.83 Wh useful)	
Ambient temperature	Operating: -20...+70°C Storage / Transport: -30...+70°C	
Temperature derating	–	See derating curve next page
Operating altitude	≤4000 m	
Max. permitted humidity	≤95 % (at +25 °C)	
Dimensions W/ H / D	202 x 232 x 110 mm (without connectors and mounting brackets)	
Housing size	2 (UPSI-IP-2 series)	
Weight	3.45 kg	3.55 kg
Input and output cable	3x 2.5 mm ² (incl. functional earth – FE) each, length 3 m, open end	

*At housing inlet and outlet, without input and output cables

Backup time* UPSI-1208IP-23U / -23UW

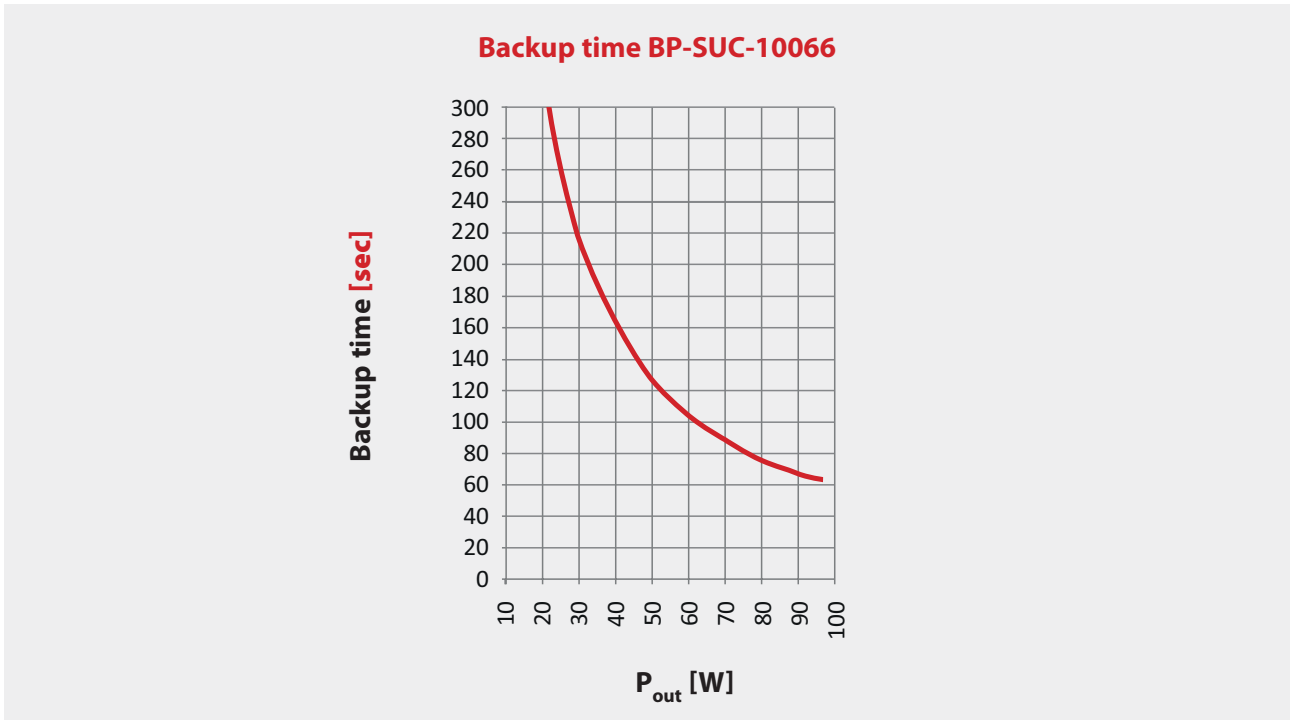

*Backup time depends on battery capacitance, load and temperature. At very high or low temperatures a reduction of backup time occurs. Unless otherwise specified, the values apply to measurements at +25 °C

Derating UPSI-1208IP-23UW

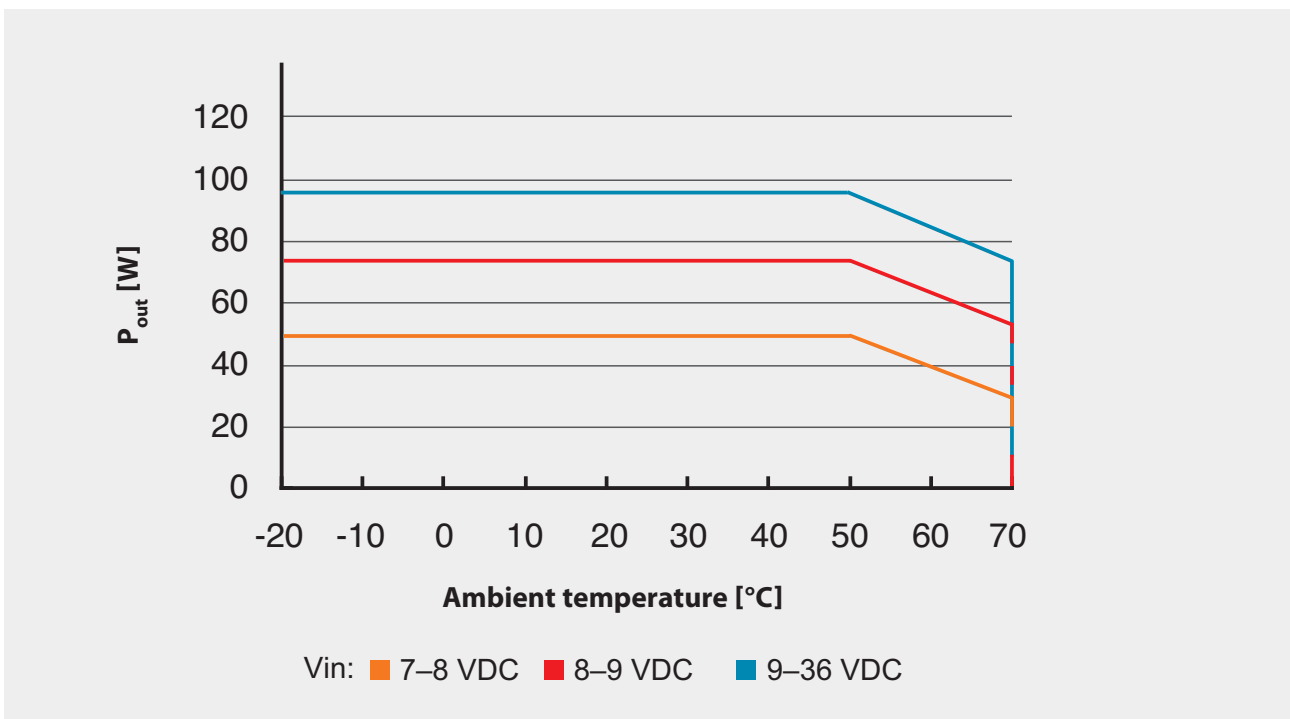

A3 Brief specification UPSI-2406IP-24U / UPSI-2406P-24UW

UPSI-2406IP-24U / 2406IP-24UW

24V/6A | 24V/5.4A

- ✓ **Outdoor DC UPS for extreme environments in robust aluminium housing with IP65/67 protection**
- ✓ **Already integrated Supercaps as energy storage (13.5 kJ)**
- ✓ **Temperature range -20...+70°C**
- ✓ **Based on UPSI-1208/-2406 technology incl. features**
- ✓ **Preassembled mounting bracket**
- ✓ **Pressure compensation element to prevent condensation inside**
- ✓ **External multifunctional interface**
- ✓ **Power and USB cable set with 3 m length each inclusive**
- ✓ **-24UW with additional wide range input**



TECHNICAL DATA	UPSI-2406IP-24U	UPSI-2406IP-24UW
Input voltage*	24 VDC (22.8...30VDC)	8...36 VDC
Input current	7.5 A max.	~14.2 A max. (depending on input voltage and load)
Output voltage*	24...23.3 VDC (depending on load)	
Output current	6 A nominal	5.4 A nominal, 5.4...6 A without charging mode (SOC = 100%), see also derating curve on next page
Capacitive load	3000 µF (at start)	
Charging method	CC/CV/CP	
Protection	Reverse polarity at input, Overcurrent protection at output, Short circuit protection at output	Overtemperature protection (DC/DC-converter), Over current protection at output, Short circuit protection at output
Interface	USB, HID UPS, RS232, Relay (not usable together)	
Battery technology	EDLC (Supercaps): 13.5 kJ (9.0 kJ useful) / 3.75 Wh (2.5 Wh useful)	
Ambient temperature	Operating: -20...+70°C Storage / Transport: -30...+70°C	
Temperature derating	–	See derating curve next page
Operating altitude	≤4000 m	
Max. permitted humidity	≤95 % (at +25°C)	
Dimensions W/ H / D	202 x 232 x 110 mm (without connectors and mounting brackets)	
Housing size	2 (UPSI-IP-2 series)	
Weight	3.69 kg	3.79 kg
Input and output cable	3x 2.5 mm ² (incl. functional earth – FE) each, length 3 m, open end	

*At housing inlet and outlet, without input and output cables

Backup time* UPSI-2406IP-24U / -24UW

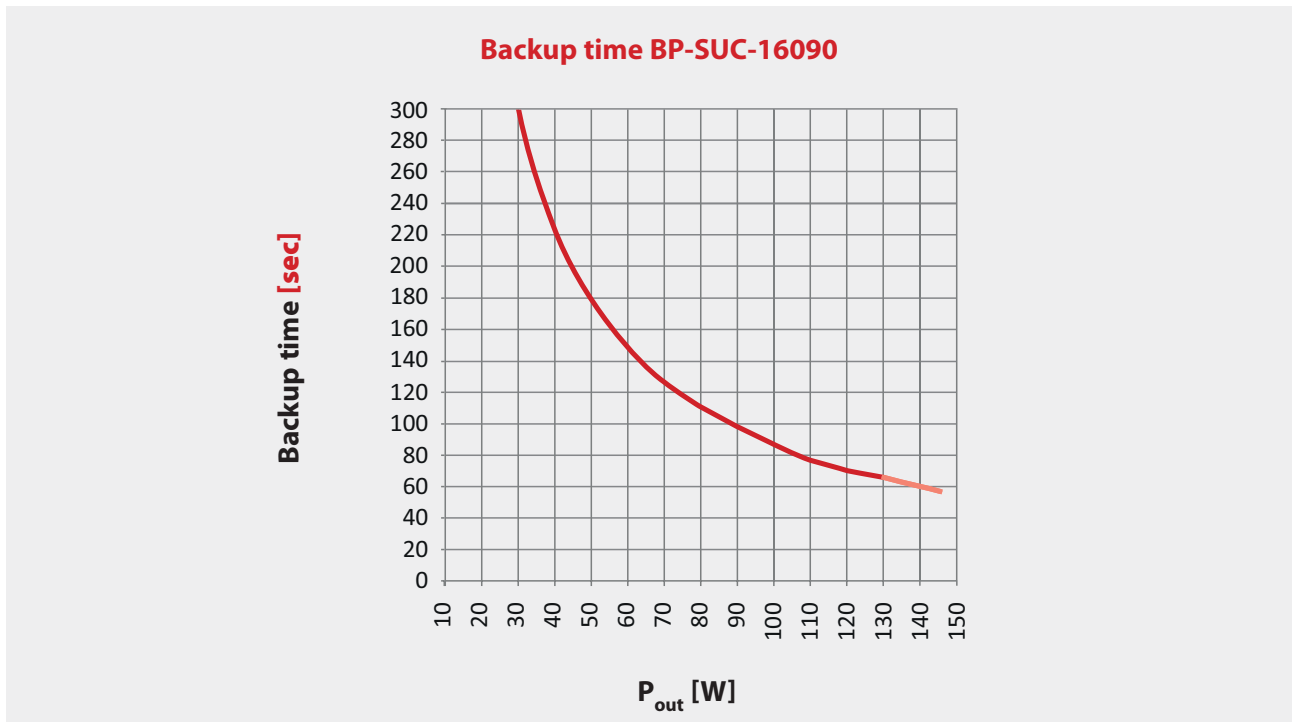

*Backup time depends on battery capacitance, load and temperature. At very high or low temperatures a reduction of backup time occurs. Unless otherwise specified, the values apply to measurements at +25 °C

Derating UPSI-2406IP-24UW

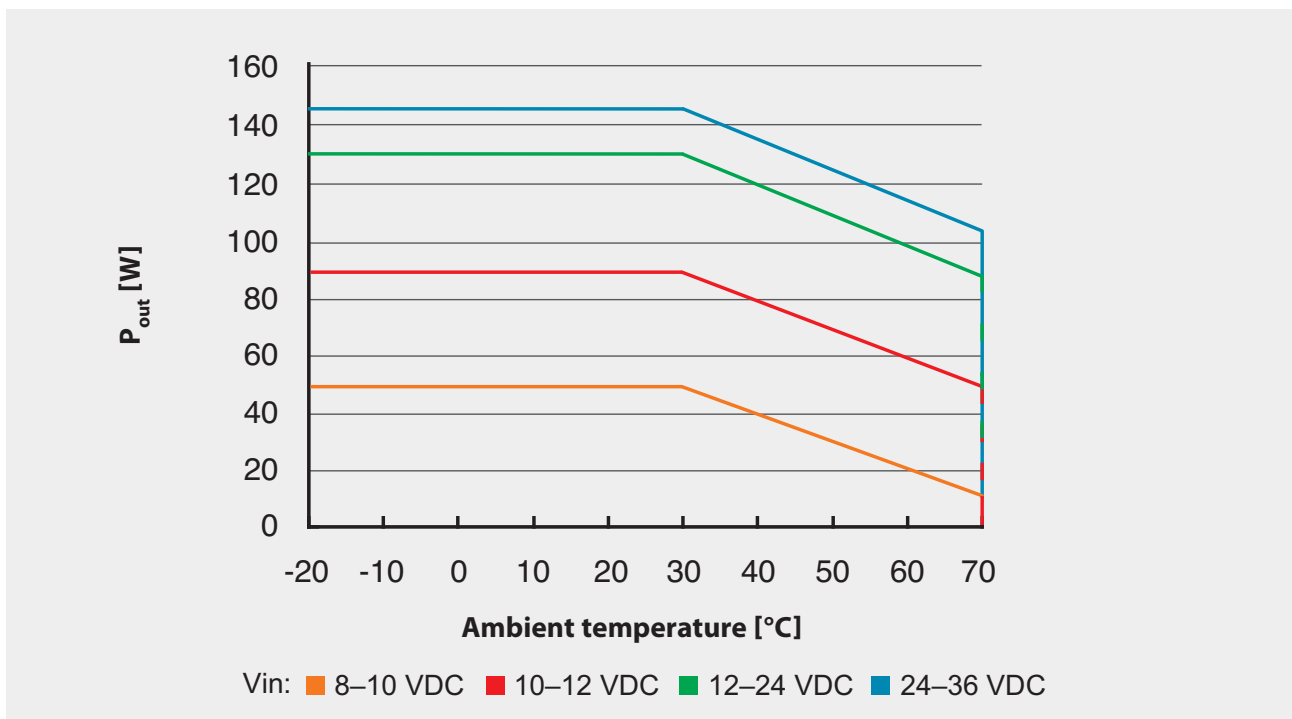

A4 Brief specification UPSI-2406IP-26U / UPSI-2406P-26UW

UPSI-2406IP-26U / 2406IP-26UW

24V/6A | 24V/4.6A

- ✓ **Outdoor DC UPS for extreme environments in robust aluminium housing with IP65/67 protection**
- ✓ **Already integrated LiFePO4 battery as energy storage (99 Wh)**
- ✓ **Temperature range -20...+55°C**
- ✓ **Based on UPSI-1208/-2406 technology incl. features**
- ✓ **Preassembled mounting bracket**
- ✓ **Pressure compensation element to prevent condensation inside**
- ✓ **External multifunctional interface**
- ✓ **Power and USB cable set with 3 m length each inclusive**
- ✓ **-26UW with additional wide range input**



TECHNICAL DATA	UPSI-2406IP-26U	UPSI-2406IP-26UW
Input voltage*	24 VDC (22.8...30VDC)	8...36 VDC
Input current	7.4 A max.	~12.9 A max. (depending on input voltage and load)
Output voltage*	24...23.3 VDC (depending on load)	
Output current	6 A nominal	4.6 A nominal, 4.6...6 A without charging mode (SOC = 100%), see also derating curve on next page
Capacitive load	3000 µF (at start)	
Charging method	CC/CV/CP	
Protection	Reverse polarity at input, Overcurrent protection at output, Short circuit protection at output	Overtemperature protection (DC/DC-converter), Over current protection at output, Short circuit protection at output
Interface	USB, HID UPS, RS232, Relay (not usable together)	
Battery technology	LiFePO4: 7.5 Ah / 99 Wh	
Ambient temperature	Operating: -20...+55°C Storage / Transport: -30...+55°C, (recommended SOC at storage: 80%)	
Temperature derating	See derating curves next page	
Operating altitude	≤4000 m	
Max. permitted humidity	≤95% (at +25°C)	
Dimensions W/ H / D	202 x 232 x 110 mm (without connectors and mounting brackets)	
Housing size	2 (UPSI-IP-2 series)	
Weight	3.72 kg	3.82 kg
Input and output cable	3x 2.5 mm ² (incl. functional earth – FE) each, length 3 m, open end	

*At housing inlet and outlet, without input and output cables

Backup time* UPSI-2406IP-26U / -26UW

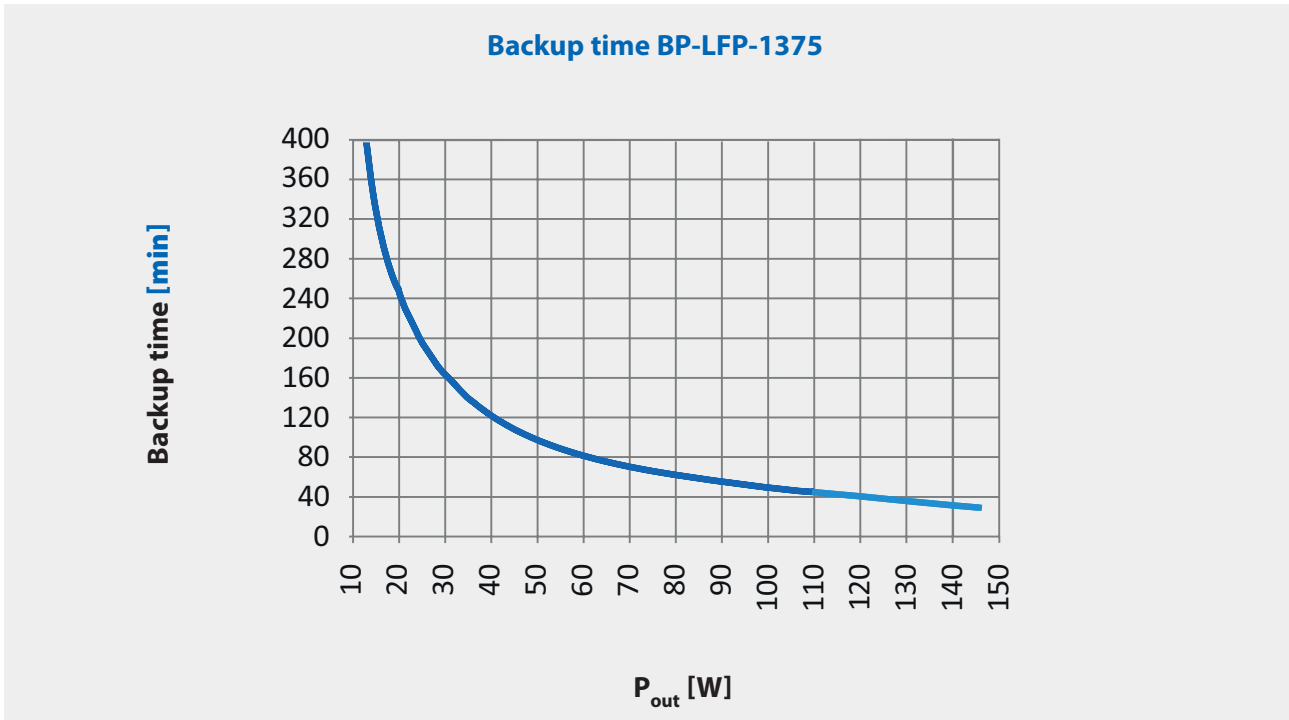

*Backup time depends on battery capacitance, load and temperature. At very high or low temperatures a reduction of backup time occurs. Unless otherwise specified, the values apply to measurements at +25 °C

Derating UPSI-2406IP-26U

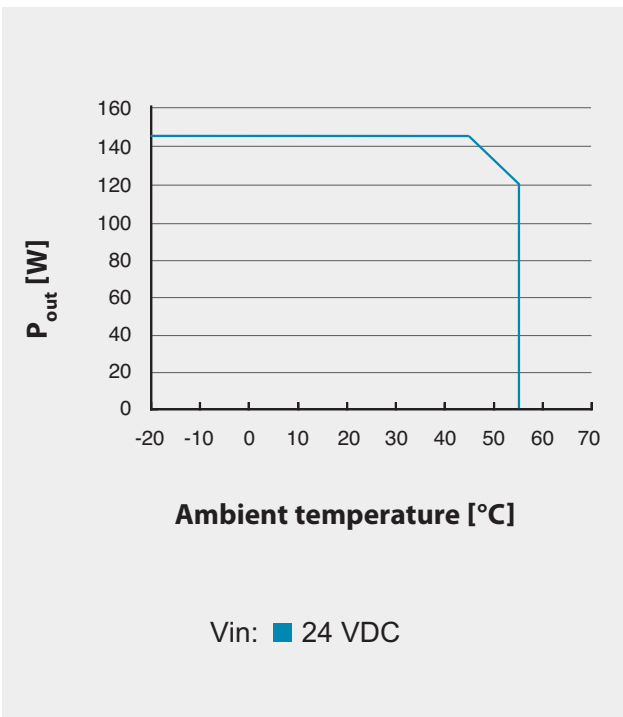

Derating UPSI-2406IP-26UW

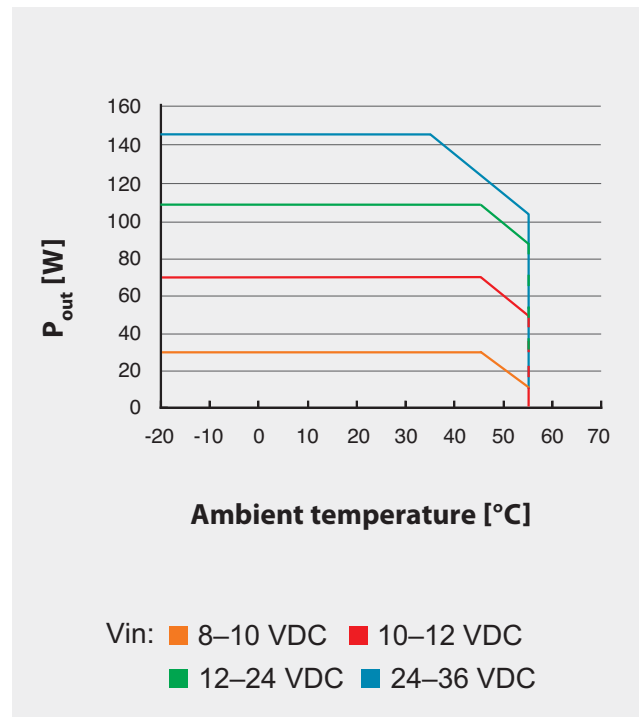

A	Brief specification	4
A1	Overview table.....	4
A2	Brief specification UPSI-1208IP-23U / UPSI-1208P-23UW	5
A3	Brief specification UPSI-2406IP-24U / UPSI-2406P-24UW	7
A4	Brief specification UPSI-2406IP-26U / UPSI-2406P-26UW	9
B	Introduction and description	12
B1	Description of the product and its functions	12
B2	Intended use – devices.....	13
B3	Intended use – connecting cables.....	13
B4	Software.....	14
C	Safety instructions.....	16
D	Technical Data.....	18
D1	Input- and output data UPSI-1208IP-23U	18
D2	Input- and output data UPSI-1208IP-23UW.....	19
D3	Input- and output data UPSI-2406IP-24U	20
D4	Input- and output data UPSI-2406IP-24UW.....	21
D5	Input- and output data UPSI-2406IP-26U	22
D6	Input- and output data UPSI-2406IP-26UW.....	23
D7	General Technical Data	24
D8	Drawing.....	31
E	Name / Address / Support E-Mail / Phone number of the manufacturer.....	31
F	General Data	32
F1	Assembly and installation advice	32
F2	Convection and installation position.....	32
F3	Description of connectors.....	33
F4	Dimensioning the upstream power supply	34
F5	Connecting diagram.....	36
F6	Initial operation.....	39
F7	Overview connector / Counterpart with description / Scope of delivery.....	40
F8	Accessories.....	40
F9	Charging time	41
F10	Reverse polarity / Overcurrent / Short circuit	41
F11	Backup time in battery mode.....	41
F12	Behaviour in case of exceeding maximum backup time.....	41
F13	Status LED.....	42
F14	Shutdown diagram.....	43
F15	Recommendations for a long UPS service life.....	44
F16	Maintenance.....	44
F17	Disposal.....	44
F18	Disclaimer.....	44
F19	Preventive measures and rules when operating the UPS system.....	44

B Introduction and description

Read carefully before initial operation!

This manual shall help the user to get familiar with the product and its components and features. It shall provide information as accurately and completely as possible.

The manual as well as all documents has to be read and followed strictly before installation. Otherwise in certain situations warranty and guarantee can be cancelled partly or completely. Any liability on the part of Bicker Elektronik is excluded for possible existing errors as well as non-compliance with the instructions for use and installation.

B1 Description of the product and its functions

The UPS devices of the UPSI-IP-2 series (hereinafter also called UPS) are DC/DC UPS systems with numerous digital features and high performance. The UPSI-1208 or UPSI-2406 is combined with an already integrated energy storage. Thereby Supercaps (also EDLCs) or a LiFePO4 battery are used. The primary use of the UPS is to secure the supply during power failures and/or voltage fluctuations. The application which should be protected is connected to the output of the UPS. The devices have IP65/67 protection and have been developed for the specific use under extreme conditions.

The -XX**U** versions require a rated dimensioned power supply of 12 VDC or 24 VDC at the input.

The -XX**UW** versions have an additional DC/DC converter, which is connected upstream of the UPS PCB and enables work with wide input range (7/8...36 VDC, **W** = Wide input range).

After the input voltage is applied, the UPS works in normal mode automatically. The input voltage is activated and the integrated energy storage device is charged simultaneously. The charging current depends dynamically on the load current at the UPS output. The green status LED lights up continuously when the UPS is in this state.

In the event of a voltage drop or a voltage fluctuation of the input voltage (below undervoltage limit), the UPS is switched to battery mode (also backup mode). The -XX**UW** versions can partially (depending on the situation, even completely) absorb this, so that the device is only switched to battery mode if there is a real voltage dropout at the input.

The application at the UPS output is supplied via the energy storage device, if the device is in battery mode. The backup time (also buffer time) depends on the used energy storage, the value of the output current and the software settings of the UPS. An important feature is that the output voltage in battery mode is always regulated to 12 VDC or 23.5 VDC and does not decrease as the voltage of the energy storage device drops. If the UPS operates in battery mode, the status LED is flashing (1 Hz flashing). For devices with an integrated LiFePO4 battery, this has to be recharged as soon as possible after a full discharge cycle in battery mode.

When the input voltage returns, the UPS is automatically switched back to normal mode and charging of the energy storage device is continued.

The UPS can also be used for user-initiated shutdowns of the supply voltage or cycles. Application examples are the replacement of larger batteries in vehicles in which the electronics should continue to be supplied, the opening and closing of safety valves after a malfunction or the shutdown of a system.

A pressure compensating element on the connection side of the housing prevents condensation inside the device.

B2 Intended use – devices

These devices are primarily designed for use under difficult and extreme environmental conditions and can be used both indoors and outdoors. They have been developed for professional use in areas such as industrial control, communication and measurement technology. These products must not be used in devices or systems in which a malfunction leads to serious injuries or endangers human life.

Unlike the standard models of the UPSI series (Open Frame or DIN-rail mounting), the housing of the UPSI-IP-2 series have IP65/67 protection. This means that the components mounted in the housing (UPS PCB and energy storage as well as DC/DC converter and input filter PCBs for -XXUW-versions) are completely protected against contact and dust (IP6x) as well as against water jets from any direction (IPx5) and water penetration when temporarily immersed in water (IPx7).

Complete protection according to IP65/67 is only given if the cables included in the scope of delivery (input, output, USB) are connected / plugged in.

If the USB interface is not required and the related USB cable is not plugged in, a suitable protective cap from Binder Connector has to be attached instead (not included in the scope of delivery). This is optionally available at Bicker Elektronik (article number „PSZ-1104“)

For permanent underwater operation, the devices are expressly **not suitable**.

B3 Intended use – connecting cables

The connection cables included in the scope of delivery may only be used with the UPS devices in accordance with the manufacturer's specifications.

The connection cables (type „ÖLFLEX® SMART 108“ from the LAPP brand) are VDE approved control cables for occasional flexible use and fixed installation under medium load conditions. They are also suitable for use in dry, damp or wet areas. If using outdoors, observe the indicated temperature range and use with UV protection. They are largely resistant to certain oils at room temperature. They are suitable for occasional, non-automated movements. The maximum tensile load is 15 N/mm² of conductor cross-section during installation and operation. Compulsory guidance is not permitted.

B4 Software

Two different software solutions are available for the UPS Gen² devices, which should be selected depending on the operating mode or desired functions.

The models have the native UPS device group “HID Power Class” integrated via USB. Most operating systems recognize the UPS via Plug & Play as HID UPS or HID battery without additional drivers and can be operated with the operating system’s own energy settings, which means self-sufficient operation without additional software. In this scenario, only the UPS Gen² Configuration Software is required to configure the internal UPS parameters.

If more functions are required, such as running a script before shutdown, the “UPScom - UPS Management Software” is the right choice. Unlike the “UPS Gen² Configuration Software”, this is permanently installed and started on the system.

UPS Gen2 Configuration Software

The UPS Gen² Configuration Software is used for setting parameters and programming new firmware for all UPSI Gen² devices under Microsoft® Windows. The software tool also shows the operating status of the UPS and its energy storage and can be connected to the device via USB.

The UPS Gen2 software tool provides additional setting options in HID power mode, such as time-bound shutdown and other important functions.

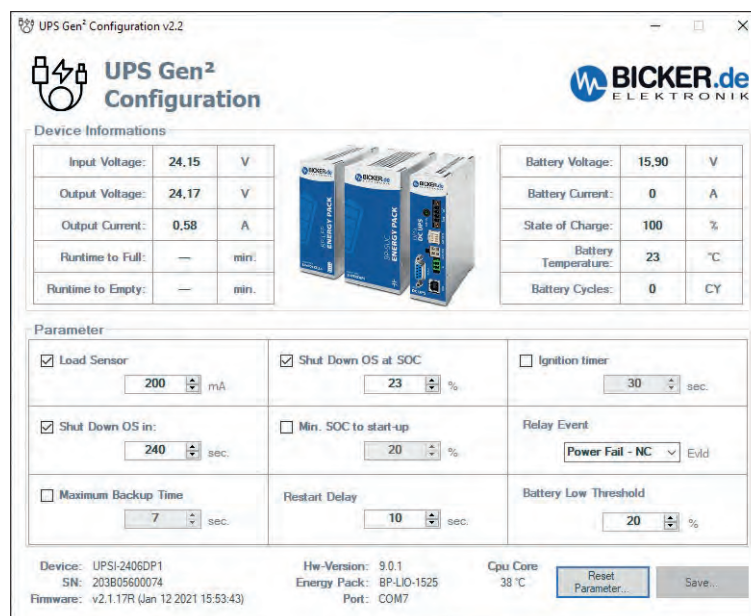

DOWNLOAD
UPS Gen2 Configuration Software

DOWNLOAD
User Manual

UPScom - UPS Management Software

During a power fail, the “UPScom” software enables controlled shutdown and switch off of connected equipment to prevent data loss or corruption. The responsive WEB UI is called up in a web browser to set and pre-program all parameters of the DC UPS system as well as for real-time monitoring with a display of the charge status.

Adjustable parameters include load sensor (mA), shutdown delay, maximum backup time, minimum load capacity before system start, email notifications and running scripts or programs before the system shuts down.

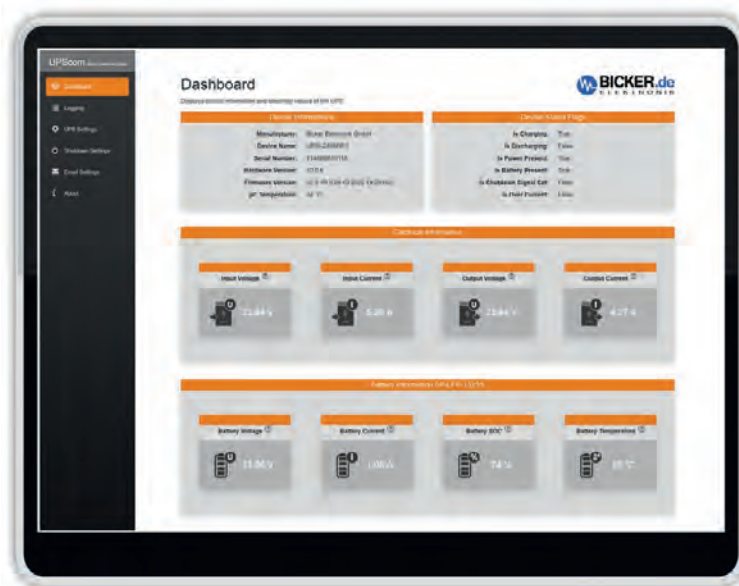

DOWNLOAD
UPScom for Windows® – All CPU

DOWNLOAD
UPScom for Linux – All CPU

C Safety instructions



WARNING!

Disregarding of following issues can result in electric shock, fire, serious injury or death.

1. Care must be taken to ensure proper and professional wiring.
2. The device pack must not be exposed to fire and temperatures outside the specification.
3. The device may only be submerged temporarily (not permanently) for up to 30 minutes under water to a depth of 1 meter.
4. The device may only be exposed to water jets up to a maximum water volume of 12.5l/min.
5. The device must not be opened, short-circuited, reversed, overheated or otherwise soldered / welded.
6. Changes or attempts to repair the device are to be omitted.
7. Effects of foreign objects on the device must be avoided (e.g. metal parts).
8. Do not put obviously damaged devices into operation (e.g. dents, burn marks, rough contamination).
9. Device must not be dropped.
10. All parts of the device and accessories must not be eaten or swallowed.
11. A current limited source is to be used. The required current values for the UPS are described in this manual.
12. The UPS is supplied with voltage from both the input source and the energy storage. The latter is still energized even after the input source has been disconnected.
13. The input and output connectors must not be plugged in or disconnected under load.
14. Appropriate safety precautions have to be taken by the user so that the input and output connectors can not be accidentally disconnected.
15. In order to correctly lock the input and output connectors with the cable connectors, they have to be tighten by hand (approx. 0.5 Nm).
16. Complete protection according to IP65 / 67 is only given if all connection cables (input, output, USB) are correctly connected. If USB is not used, the connection has to be covered with a suitable protective cap.



ATTENTION!

1. Improper use and opening of the device will void the warranty.
2. The device may only be used as intended.
3. The national accident prevention and safety regulations must be observed.
4. The assembly of the device and the electrical installation have to be state of the art.
5. The electrical, thermal and mechanical limit values have to be observed.
6. The UPS wiring specifications - as described in this manual - have to be followed.

D Technical Data

D1 INPUT- AND OUTPUT DATA UPSI-1208IP-23U		
Unless otherwise stated, all specifications apply to 25 °C ambient temperature, 24 VDC input voltage and nominal output current (I_N).		
Input voltage*	12 VDC	
Input voltage range*	11.5 VDC...16 VDC	
Electric strength max.	18 VDC	
Fixed connect threshold		
Undervoltage	11.3 VDC	
Voltage drop Input/Output	0.65 VDC (depending on load)	
Current consumption		
I_N ($U_N, I_{OUT} = I_N, I_{CHARGE} = 0$)	8.2 A	
I_{MAX} ($U_N, I_{OUT} = I_{STAT.BOOST}, I_{CHARGE} = \max$)	9.2 A	
I_{DYN} ($U_N, I_{OUT} = I_{DYN.BOOST}, I_{CHARGE} = 0$)	9.7 A	
$I_{NO-LOAD}$ ($U_N, I_{OUT} = 0, I_{CHARGE} = 0$)	<200 mA	
I_{CHARGE} ($U_N, I_{OUT} = 0, I_{CHARGE} = \max$)	3.9 A	
Power consumption		
P_N ($U_N, I_{OUT} = I_N, I_{CHARGE} = 0$)	98.5 W	
P_{MAX} ($U_N, I_{OUT} = I_{STAT.BOOST}, I_{CHARGE} = \max$)	110.5 W	
P_{DYN} ($U_N, I_{OUT} = I_{DYN.BOOST}, I_{CHARGE} = 0$)	116.5 W	
P_{CHARGE} ($U_N, I_{OUT} = 0, I_{CHARGE} = \max$)	47 W	
Internal input fuse	Yes (15 A)	
Switch-on time / Switch-on time battery start (BS)	<5 sec / n.a.	
	NORMAL MODE	BATTERY MODE
Output voltage*	12...11.35 VDC (depending on load)	12...11.85 VDC (depending on load)
Capacitive load	3000 μ F (at start)	n.a.
Output current		
I_N	8 A	8 A
$I_{STAT.BOOST}$	8.4 A	8.4 A
$I_{DYN.BOOST}$	8.5...9.5 A for max. 3 s	8.5...9.5 A for max. 3 s
I_{SFB}	30 A (5 ms)	30 A (5 ms)
Output power		
P_N ($U_N, I_{OUT} = I_N, I_{CHARGE} = 0$)	91 W	95 W
$P_{STAT.BOOST}$ ($U_N, I_{OUT} = I_{STAT.BOOST}, I_{CHARGE} = 0$)	95.5 W	100 W
$P_{DYN.BOOST}$ ($U_N, I_{OUT} = I_{DYN.BOOST}, I_{CHARGE} = 0$)	96.5...108 W for max. 3 s	101...112 W for max. 3 s
Short-circuit proof	Yes	
No-load proof	Yes	
Overcurrent shutdown	8.5...9.5 A for max. 3 s; 9.6...10.8 A for max. 100 ms; >10.8 A for max. 5 ms	
Switching time normal mode >> battery mode	<600 μ s	

*At housing inlet and outlet, without input and output cables

D2 INPUT- AND OUTPUT DATA UPSI-1208IP-23UW All specifications apply to 25 °C ambient temperature		
Input voltage*	12 VDC	
Input voltage range*	7 VDC ... 36 VDC	
Electric strength max.	36 VDC	
Fixed connect threshold		
Undervoltage (at $I_{OUT}=0$; $I_{CHARGE}=0$)	4.25 VDC	
Voltage drop Input/Output (at $U_{IN} = 12V$)	0.65 VDC (depending on load)	
Power consumption		
I_N at $U_{IN} = 24V$; $I_{OUT} = 8A$; $I_{CHARGE} = 0$	4.25 A	
I_N at $U_{IN} = 12V$; $I_{OUT} = 8A$; $I_{CHARGE} = 0$	8.5 A	
I_{MAX} at $U_{IN} = 24V$; $I_{OUT} = I_{STAT.BOOST}$; $I_{CHARGE} = \max$	4.8 A	
I_{MAX} at $U_{IN} = 12V$; $I_{OUT} = I_{STAT.BOOST}$; $I_{CHARGE} = \max$	9.7 A	
I_{DYN} at $U_{IN} = 24V$; $I_{OUT} = I_{DYN.BOOST}$; $I_{CHARGE} = 0$	4.9 A	
I_{DYN} at $U_{IN} = 12V$; $I_{OUT} = I_{DYN.BOOST}$; $I_{CHARGE} = 0$	10 A	
$I_{NO-LOAD}$ at $U_{IN} = 24V/12V$; $I_{OUT} = 0$; $I_{CHARGE} = 0$	<150 / <300 mA	
I_{CHARGE} at $U_{IN} = 24V/12V$; $I_{OUT} = 0$; $I_{CHARGE} = \max$	2.4 A / 3.9 A	
Power consumption		
P_N at $U_{IN} = 24V$; $I_{OUT} = 8A$; $I_{CHARGE} = 0$	102 W	
P_N at $U_{IN} = 12V$; $I_{OUT} = 8A$; $I_{CHARGE} = 0$	102 W	
P_{MAX} at $U_{IN} = 24V$; $I_{OUT} = I_{STAT.BOOST}$; $I_{CHARGE} = \max$	115 W	
P_{MAX} at $U_{IN} = 12V$; $I_{OUT} = I_{STAT.BOOST}$; $I_{CHARGE} = \max$	116.5 W	
P_{DYN} at $U_{IN} = 24V$; $I_{OUT} = I_{DYN.BOOST}$; $I_{CHARGE} = 0$	118 W	
P_{DYN} at $U_{IN} = 12V$; $I_{OUT} = I_{DYN.BOOST}$; $I_{CHARGE} = 0$	120 W	
P_{CHARGE} at $U_{IN} = 24V/12V$; $I_{OUT} = 0$; $I_{CHARGE} = \max$	48...47 W	
Internal input fuse	Yes (20 A)	
Switch-on time / Switch-on time battery start (BS)	<5 sec / n.a.	
	NORMAL MODE	BATTERY MODE
Output voltage*	12...11.35 VDC (depending on load)	12...11.85 VDC (depending on load)
Capacitive load	3000 μ F (at start)	n.a.
Output current		
I_N at $U_{IN} = 9...36V$	8 A	8 A
I_N from $U_{IN} = 8V$	6.25 A	6.25 A
I_N from $U_{IN} = 7V$	4.17 A	4.17 A
$I_{STAT.BOOST}$ at $U_{IN} = 24...36V$	8.4 A	8.4 A
$I_{DYN.BOOST}$ at $U_{IN} = 24...36V$	8.5...9.5 A for max. 3 s	8.5...9.5 A for max. 3 s
I_{SFB}	30 A (5 ms)	30 A (5 ms)
Output power		
P_N at $U_{IN} = 9...36V$; $I_{OUT} = 8A$; $I_{CHARGE} = 0$	91 W	95 W
P_N at $U_{IN} = 8V$; $I_{OUT} = 6.25A$; $I_{CHARGE} = 0$	72 W	74.5W
P_N at $U_{IN} = 7V$; $I_{OUT} = 4.17A$; $I_{CHARGE} = 0$	49 W	50 W
$P_{STAT.BOOST}$ at $U_{IN} = 24...36V$; $I_{OUT} = I_{STAT.BOOST}$; $I_{CHARGE} = 0$	95.5 W	100 W
$P_{DYN.BOOST}$ at $U_{IN} = 24...6V$; $I_{OUT} = I_{DYN.BOOST}$; $I_{CHARGE} = 0$	96.5...108 W for max. 3 s	101...112 W for max. 3 s
Short-circuit proof	Yes	
No-load proof	Yes	
Overcurrent shutdown	8.5...9.5 A for max. 3 s; 9.6...10.8 A for max. 100 ms; >10.8 A for max. 5 ms	
Switching time normal mode >> battery mode	<600 μ s	

*At housing inlet and outlet, without input and output cables

D3 INPUT- AND OUTPUT DATA UPSI-2406IP-24U

Unless otherwise stated, all specifications apply to 25 °C ambient temperature, 24 VDC input voltage and nominal output current (I_N).

Input voltage*	24 VDC	
Input voltage range*	22.8 VDC...30 VDC	
Electric strength max.	35 VDC	
Fixed connect threshold		
Undervoltage	22 VDC	
Voltage drop Input/Output	0.4 VDC (depending on load)	
Current consumption		
I_N ($U_N, I_{OUT} = I_N, I_{CHARGE} = 0$)	6.1 A	
I_{MAX} ($U_N, I_{OUT} = I_{STAT.BOOST}, I_{CHARGE} = \max$)	7.5 A	
I_{DYN} ($U_N, I_{OUT} = I_{DYN.BOOST}, I_{CHARGE} = 0$)	7.6 A	
$I_{NO-LOAD}$ ($U_N, I_{OUT} = 0, I_{CHARGE} = 0$)	<100 mA	
I_{CHARGE} ($U_N, I_{OUT} = 0, I_{CHARGE} = \max$)	2.4 A	
Power consumption		
P_N ($U_N, I_{OUT} = I_N, I_{CHARGE} = 0$)	146 W	
P_{MAX} ($U_N, I_{OUT} = I_{STAT.BOOST}, I_{CHARGE} = \max$)	180 W	
P_{DYN} ($U_N, I_{OUT} = I_{DYN.BOOST}, I_{CHARGE} = 0$)	182 W	
P_{CHARGE} ($U_N, I_{OUT} = 0, I_{CHARGE} = \max$)	58 W	
Internal input fuse	Yes (15 A)	
Switch-on time / Switch-on time battery start (BS)	<5 sec / n.a.	
	NORMAL MODE	BATTERY MODE
Output voltage*	24...23.6 VDC (depending on load)	23.6...23.3 VDC (depending on load)
Capacitive load	3000 μ F (at start)	n.a.
Output current		
I_N	6 A	6 A
$I_{STAT.BOOST}$	6.3 A	6.3 A
$I_{DYN.BOOST}$	6.4...7.5 A for max. 3 s	6.4...7.5 A for max. 3 s
I_{SFB}	30 A (5 ms)	30 A (5 ms)
Output power		
P_N ($U_N, I_{OUT} = I_N, I_{CHARGE} = 0$)	142 W	140 W
$P_{STAT.BOOST}$ ($U_N, I_{OUT} = I_{STAT.BOOST}, I_{CHARGE} = 0$)	149 W	147 W
$P_{DYN.BOOST}$ ($U_N, I_{OUT} = I_{DYN.BOOST}, I_{CHARGE} = 0$)	150...176 W for max. 3 s	149...175 W for max. 3 s
Short-circuit proof	Yes	
No-load proof	Yes	
Overcurrent shutdown	6.4...7.5 A for max. 3 s; 7.6...10.8 A for max. 100 ms; >10.8 A for max. 5 ms	
Switching time normal mode >> battery mode	<600 μ s	

*At housing inlet and outlet, without input and output cables

D4 INPUT- AND OUTPUT DATA UPSI-2406IP-24UW
All specifications at 25°C ambient temperature

Input voltage*	24 VDC	
Input voltage range*	8 VDC ... 36VDC	
Electric strength max.	36 VDC	
Fixed connect threshold		
Undervoltage (at $I_{OUT}=0$; $I_{CHARGE}=0$)	4.3 VDC	
Voltage drop Input/Output (at $U_{IN} = 24V$)	0.4 VDC (depending on load)	
Current consumption		
I_N at $U_{IN} = 24V$; $I_{OUT} = 6A$; $I_{CHARGE} = 0$	6.3 A	
I_N at $U_{IN} = 12V$; $I_{OUT} = 5.4A$; $I_{CHARGE} = 0$	11.67 A	
I_{MAX} at $U_{IN} = 24V$; $I_{OUT} = I_{STAT.BOOST}$; $I_{CHARGE} = 0$	6.6 A	
I_{MAX} at $U_{IN} = 12V$; $I_{OUT} = 5.4A$; $I_{CHARGE} = \max$	14.2 A	
I_{DYN} at $U_{IN} = 24V$; $I_{OUT} = I_{DYN.BOOST}$; $I_{CHARGE} = 0$	7.8 A	
$I_{NO-LOAD}$ at $U_{IN} = 24V / 12V$; $I_{OUT} = 0$; $I_{CHARGE} = 0$	<150 / <300 mA	
I_{CHARGE} at $U_{IN} = 24V / 12V$; $I_{OUT} = 0$; $I_{CHARGE} = \max$	2.4 A / 4.9 A	
Power consumption		
P_N at $U_{IN} = 24V$; $I_{OUT} = 6A$; $I_{CHARGE} = 0$	151 W	
P_N at $U_{IN} = 12V$; $I_{OUT} = 5.4A$; $I_{CHARGE} = 0$	140 W	
P_{MAX} at $U_{IN} = 24V$; $I_{OUT} = I_{STAT.BOOST}$; $I_{CHARGE} = 0$	158.5 W	
P_{MAX} at $U_{IN} = 12V$; $I_{OUT} = 5.4A$; $I_{CHARGE} = \max$	170 W	
P_{DYN} at $U_{IN} = 24V$; $I_{OUT} = I_{DYN.BOOST}$; $I_{CHARGE} = 0$	187 W	
P_{CHARGE} at $U_{IN} = 24V / 12V$; $I_{OUT} = 0$; $I_{CHARGE} = \max$	58...59 W	
Internal input fuse	Yes (20 A)	
Switch-on time / Switch-on time battery start (BS)	<5 sec / n.a.	
	NORMAL MODE	BATTERY MODE
Output voltage*	24... 23.6 VDC (depending on load)	23.6...23.3 VDC (depending on load)
Capacitive load	3000 µF (at start)	n.a.
Output current		
I_N at $U_{IN} = 24...36V$	6 A	6 A
I_N from $U_{IN} = 12V$	5.4 A	5.4 A
I_N from $U_{IN} = 10V$	3.75 A	3.75 A
I_N from $U_{IN} = 8V$	2.08 A	2.08 A
$I_{STAT.BOOST}$ at $U_{IN} = 24...36V$	6.3 A	6.3 A
$I_{DYN.BOOST}$ at $U_{IN} = 24...36V$	6.4...7.5 A for max 3 s	6.4...7.5 A for max 3 s
I_{SFB}	30 A (5 ms)	30 A (5 ms)
Output power		
P_N at $U_{IN} = 24...36V$; $I_{OUT} = 6A$; $I_{CHARGE} = 0$	142 W	140 W
P_N at $U_{IN} = 12V$; $I_{OUT} = 5.4A$; $I_{CHARGE} = 0$	128 W	127 W
P_N at $U_{IN} = 10V$; $I_{OUT} = 3.75A$; $I_{CHARGE} = 0$	89 W	88 W
P_N at $U_{IN} = 8V$; $I_{OUT} = 2.08A$; $I_{CHARGE} = 0$	49 W	49 W
$P_{STAT.BOOST}$ at $U_{IN} = 24...36V$; $I_{OUT} = I_{STAT.BOOST}$; $I_{CHARGE} = 0$	149 W	149 W
$P_{DYN.BOOST}$ at $U_{IN} = 24...36V$; $I_{OUT} = I_{DYN.BOOST}$; $I_{CHARGE} = 0$	152...177 W for max. 3 s	150...175 W for max. 3 s
Short-circuit proof	Yes	
No-load proof	Yes	
Overcurrent shutdown	6.4...7.5 A for max. 3 s; 7.6...10.8 A for max. 100 ms; >10.8 A for max. 5 ms	
Switching time normal mode >> battery mode	<600 µs	

*At housing inlet and outlet, without input and output cables

D5 INPUT- AND OUTPUT DATA UPSI-2406IP-26U

Unless otherwise stated, all specifications apply to 25 °C ambient temperature, 24 VDC input voltage and nominal output current (I_N).

Input voltage*	24 VDC	
Input voltage range*	22.8 VDC...30 VDC	
Electric strength max.	35 VDC	
Fixed connect threshold		
Undervoltage	22 VDC	
Voltage drop Input/Output	0.4 VDC (depending on load)	
Current consumption		
I_N ($U_N, I_{OUT} = I_N, I_{CHARGE} = 0$)	6.1 A	
I_{MAX} ($U_N, I_{OUT} = I_{STAT.BOOST}, I_{CHARGE} = \max$)	7.4 A	
I_{DYN} ($U_N, I_{OUT} = I_{DYN.BOOST}, I_{CHARGE} = 0$)	7.6 A	
$I_{NO-LOAD}$ ($U_N, I_{OUT} = 0, I_{CHARGE} = 0$)	<100 mA	
I_{CHARGE} ($U_N, I_{OUT} = 0, I_{CHARGE} = \max$)	2.25 A	
Power consumption		
P_N ($U_N, I_{OUT} = I_N, I_{CHARGE} = 0$)	146 W	
P_{MAX} ($U_N, I_{OUT} = I_{STAT.BOOST}, I_{CHARGE} = \max$)	177 W	
P_{DYN} ($U_N, I_{OUT} = I_{DYN.BOOST}, I_{CHARGE} = 0$)	182 W	
P_{CHARGE} ($U_N, I_{OUT} = 0, I_{CHARGE} = \max$)	54 W	
Internal input fuse	Yes (15 A)	
Switch-on time / Switch-on time battery start (BS)	<5 sec / n.a.	
	NORMAL MODE	BATTERY MODE
Output voltage*	24...23.6 VDC (depending on load)	23.6...23.3 VDC (depending on load)
Capacitive load	3000 μ F (at start)	n.a.
Output current		
I_N	6 A	6 A
$I_{STAT.BOOST}$	6.3 A	6.3 A
$I_{DYN.BOOST}$	6.4...7.5 A for max. 3 s	6.4...7.5 A for max. 3 s
I_{SFB}	30 A (5 ms)	30 A (5 ms)
Output power		
P_N ($U_N, I_{OUT} = I_N, I_{CHARGE} = 0$)	142 W	140 W
$P_{STAT.BOOST}$ ($U_N, I_{OUT} = I_{STAT.BOOST}, I_{CHARGE} = 0$)	149 W	147 W
$P_{DYN.BOOST}$ ($U_N, I_{OUT} = I_{DYN.BOOST}, I_{CHARGE} = 0$)	150...176 W for max. 3 s	149...175 W for max. 3 s
Short-circuit proof	Yes	
No-load proof	Yes	
Overcurrent shutdown	6.4...7.5 A for max. 3 s; 7.6...10.8 A for max. 100 ms; >10.8 A for max. 5 ms	
Switching time normal mode >> battery mode	<600 μ s	

*At housing inlet and outlet, without input and output cables

D6 INPUT- AND OUTPUT DATA UPSI-2406IP-26UW All specifications at 25 °C ambient temperature		
Input voltage*	24 VDC	
Input voltage range*	8 VDC ... 36VDC	
Electric strength max.	36 VDC	
Fixed connect threshold		
Undervoltage (at $I_{OUT}=0$; $I_{CHARGE}=0$)	4.3 VDC	
Voltage drop Input/Output (at $U_{IN} = 24V$)	0.4 VDC (depending on load)	
Current consumption		
I_N at $U_{IN} = 24V$; $I_{OUT} = 6A$; $I_{CHARGE} = 0$	6.3 A	
I_N at $U_{IN} = 12V$; $I_{OUT} = 4.6A$; $I_{CHARGE} = 0$	9.85 A	
I_{MAX} at $U_{IN} = 24V$; $I_{OUT} = I_{STAT.BOOST}$; $I_{CHARGE} = 0$	6.6 A	
I_{MAX} at $U_{IN} = 12V$; $I_{OUT} = 4.6A$; $I_{CHARGE} = \max$	12.8 A	
I_{DYN} at $U_{IN} = 24V$; $I_{OUT} = I_{DYN.BOOST}$; $I_{CHARGE} = 0$	7.8 A	
$I_{NO-LOAD}$ at $U_{IN} = 24V / 12V$; $I_{OUT} = 0$; $I_{CHARGE} = 0$	<150 / <300 mA	
I_{CHARGE} at $U_{IN} = 24V / 12V$; $I_{OUT} = 0$; $I_{CHARGE} = \max$	2.3 A / 4.7 A	
Power consumption		
P_N at $U_{IN} = 24V$; $I_{OUT} = 6A$; $I_{CHARGE} = 0$	151 W	
P_N at $U_{IN} = 12V$; $I_{OUT} = 4.6A$; $I_{CHARGE} = 0$	118 W	
P_{MAX} at $U_{IN} = 24V$; $I_{OUT} = I_{STAT.BOOST}$; $I_{CHARGE} = 0$	158.5 W	
P_{MAX} at $U_{IN} = 12V$; $I_{OUT} = 4.6A$; $I_{CHARGE} = \max$	154 W	
P_{DYN} at $U_{IN} = 24V$; $I_{OUT} = I_{DYN.BOOST}$; $I_{CHARGE} = 0$	187 W	
P_{CHARGE} at $U_{IN} = 24V / 12V$; $I_{OUT} = 0$; $I_{CHARGE} = \max$	55...56 W	
Internal input fuse	Yes (20 A)	
Switch-on time / Switch-on time battery start (BS)	<5 sec / n.a.	
	NORMAL MODE	BATTERY MODE
Output voltage*	24... 23.6 VDC (depending on load)	23.6...23.3 VDC (depending on load)
Capacitive load	3000 μ F (at start)	n.a.
Output current		
I_N at $U_{IN} = 24...36V$	6 A	6 A
I_N ab $U_{IN} = 12V$	4.6 A	4.6 A
I_N ab $U_{IN} = 10V$	2.92 A	1.25 A
I_N ab $U_{IN} = 8V$	1.25 A	1.25 A
$I_{STAT.BOOST}$ at $U_{IN} = 24...36V$	6.3 A	6.3 A
$I_{DYN.BOOST}$ at $U_{IN} = 24...36V$	6.4...7.5 A for max 3 s	6.4...7.5 A for max 3 s
I_{SFB}	30 A (5 ms)	30 A (5 ms)
Output power		
P_N at $U_{IN} = 24...36V$; $I_{OUT} = 6A$; $I_{CHARGE} = 0$	142 W	140 W
P_N at $U_{IN} = 12V$; $I_{OUT} = 4.6A$; $I_{CHARGE} = 0$	109 W	108 W
P_N at $U_{IN} = 10V$; $I_{OUT} = 2.92A$; $I_{CHARGE} = 0$	69 W	68 W
P_N at $U_{IN} = 8V$; $I_{OUT} = 1.25A$; $I_{CHARGE} = 0$	30 W	29 W
$P_{STAT.BOOST}$ at $U_{IN} = 24...36V$; $I_{OUT} = I_{STAT.BOOST}$; $I_{CHARGE} = 0$	149 W	149 W
$P_{DYN.BOOST}$ at $U_{IN} = 24...36V$; $I_{OUT} = I_{DYN.BOOST}$; $I_{CHARGE} = 0$	152...177 W for max. 3 s	150...175 W for max. 3 s
Short-circuit proof	Yes	
No-load proof	Yes	
Overcurrent shutdown	6.4...7.5 A for max. 3 s; 7.6...10.8 A for max. 100 ms; >10.8 A for max. 5 ms	
Switching time normal mode >> battery mode	<600 μ s	

*At housing inlet and outlet, without input and output cables

D7 General Technical Data

ENERGY STORAGE UPSI-1208IP-23U / UPSI-1208IP-23UW	
Installed type	BP-SUC-10066
Battery technology	EDLC (Supercaps)
Charging method	CC / CV / CP
Nominal voltage U_N	10.4 V
End-of-charge voltage	10.4 V
Charging current	4.5...5.0 A, 15 A max.
Undervoltage protection	5.0V
Nominal capacity	9.8 kJ (6.6 kJ useful) / 2.72 Wh (1.83 Wh useful)
Charging time (I_{charge_max})	~6 min...6 min 30 sec
Buffer time (I_N)	1 min 15 sec
ENERGY STORAGE UPSI-2406IP-24U / UPSI-2406IP-24UW	
Installed type	BP-SUC-16090
Battery technology	EDLC (Supercaps)
Charging method	CC / CV / CP
Nominal voltage U_N	15.2V
End-of-charge voltage	15.2V
Charging current	4.5...5.0A, 16A max.
Undervoltage protection	5.0V
Nominal capacity	13.5 kJ (9.0 kJ useful) / 3.75 Wh (2.5 Wh useful)
Charging time (I_{charge_max})	~7 min...7 min 30 sec
Buffer time (I_N)	1 min 5 sec
ENERGY STORAGE UPSI-2406IP-26U / UPSI-2406IP-26UW	
Installed type	BP-LFP-1375
Battery technology	LiFePo4
Charging method	CC / CV / CP
Nominal voltage U_N	13.2V
End-of-charge voltage	13.8V
Charging current	$\leq 1C$ (4.5 A max.)
Undervoltage protection	2.4V (Cell level)
Nominal capacity	7.5 Ah / 99 Wh
Charging time (I_{charge_max})	~115 min
Buffer time (I_N)	31 min

CONNECTION DATA INPUT / OUTPUT (HOUSING)

Connector	Input	Output
Connector type	Flange plug	Flange socket
Design	Pin (male), straight	Socket (female), straight
Connection locking	Central screw	
Chassis-internal contact type: Stranded wire to connectors	Screw clamp type	
Mechanical service lifetime	>500 plug cycles	
Stranded wire size and cross section internal	Outward and downward stranded wires (Power): AWG16 (app. 1.5 mm ²) FE stranded wire: AWG18 (app. 1.0 mm ²)	

CONNECTION DATA INPUT / OUTPUT (CABLE)

Connector	Input	Output
Connector type	Cable socket	Cable plug
Design	Socket (female), straight	Pin (male), straight
Chassis-internal contact type: Stranded wire to connectors	Screw clamp type	
Mechanical service lifetime	>500 plug cycles	
Tightening force / Torque	0.5 Nm (hand-tightened)	
Type of cable	ÖLFLEX® SMART 108 - PVC control cable, 3G2,5	
Cable construction	Fine wire strands of bare copper, PVC conductor isolation, T12; Two-layer design, PVC, TM2; Colour: outside silver grey, inside black	
Outside diameter cable	8.1 mm	
Stranded wire cross section	2x Stranded wire (Power): each 2.5 mm ² ; 1x Stranded wire (FE): 2.5 mm ²	
Minimum bending radius	Occasional flexing: 15x outer diameter Fixed installation: 4x outer diameter	
Temperature range	Occasional flexing: -5 °C...+70 °C max. conductor temp. Fixed installation: -40 °C...+80 °C max. conductor temp.	

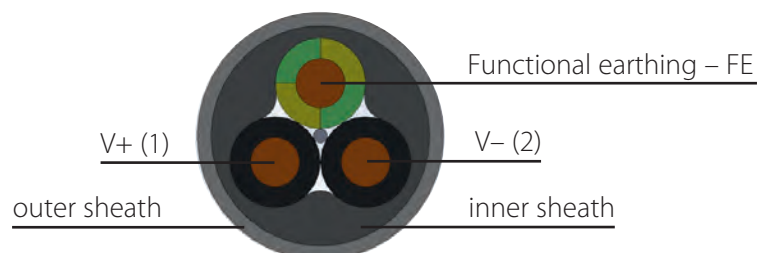

CONNECTION DATA – MULTIFUNCTIONAL INTERFACE

Connector type	Flange socket
Design	Socket (female), straight
Connection locking	Snap
Chassis-internal contact type: stranded wire to connectors	Solder
Mechanical service lifetime	>500 plug cycles
Stranded wire size and cross section internal	5x AWG24 (ca. 0.25 mm ²)

MULTIFUNCTIONAL INTERFACE – USB

Transmission physics	USB 2.0
Topology	Point-to-point
Protocol	VCOM, HID
Transmission length	≤3 m
Access time	<1 s
Chipset	NXP
Electrical isolation	No

MULTIFUNCTIONAL INTERFACE – RS232

Transmission physics	RS232 light (TX/RX)
Topology	Point-to-point
Symbol rate (baud rate)	38400
Transmission length	≤10 m
Access time	<1 s
Voltage level	-6 VDC...+6 VDC
Electrical isolation	No

MULTIFUNCTIONAL INTERFACE – RELAY

Switch contact (potential free)	Relay
Switching voltage	24 VDC
Current carrying capacity	1 A
Status (configurable)	Power Fail Alarm
State - signal assignment	NO (Normally Open) / NC (Normally Closed) – configurable Software (see UPS Gen ² configuration software manual)
Conductor cross-section	AWG24

GENERAL DATA	
Flammability class according to UL 94	V0
Weight	UPSI-1208IP-23U: 3.45 kg UPSI-1208IP-23UW: 3.55 kg UPSI-2406IP-24U: 3.69 kg UPSI-2406IP-24UW: 3.79 kg UPSI-2406IP-26U: 3.72 kg UPSI-2406IP-26UW: 3.82 kg
UPS connection in parallel	No
UPS connection in series	No

HOUSING	
Degree of protection	IP 65/67
Protection class	III (with FE)
Mounting type	Wall or surface mounting (or equal)
Housing version	Aluminium die-cast housing, EN AC – AlSi12(Fe); powder-coated, colour RAL 7001 silver grey
Dimension W / H / D	202 mm / 232 mm / 110 mm (without connectors and mounting brackets)

ENVIRONMENTAL CONDITIONS	
Ambient temperature (operation)*	UPSI-1208IP-23U, UPSI-1208IP-23UW, UPSI-2406IP-24U, UPSI-2406IP-24UW: -20...+70 °C UPSI-2406IP-26U, UPSI-2406IP-26UW: -20...+55 °C
Ambient temperature (start up without load)	UPSI-1208IP-23U, UPSI-1208IP-23UW, UPSI-2406IP-24U, UPSI-2406IP-24UW: -30 °C UPSI-2406IP-26U, UPSI-2406IP-26UW: -20 °C
Ambient temperature (storage / transport)	UPSI-1208IP-23U, UPSI-1208IP-23UW, UPSI-2406IP-24U, UPSI-2406IP-24UW: -30...+70 °C UPSI-2406IP-26U, UPSI-2406IP-26UW: -30...+55 °C , (recommended SOC at storage: 80 %)
Max. permitted humidity	≤95 % (at +25 °C)
Operating altitude	≤4000 m
Climate class	3K24 (EN 60721-3-3:2020-5)
Degree of pollution	4
Overvoltage category	
EN 61010-1	I
EN 61010-2-201	I
Indoor / Outdoor use	Yes / Yes
Testing of environmental influences (shock and vibration)	n.a. (possible upon consultation)

STANDARDS	
Safety extra-low voltage	IEC 61010-1 (SELV) IEC 61010-2-201

APPROVALS	
UL	n.a. (possible upon consultation)
CSA	n.a. (possible upon consultation)
CB Scheme	n.a. (possible upon consultation)

*Derating due to the ambient temperature has to be observed.
(see derating curves in the brief specifications on the previous pages)

INTERFERENCE IMMUNITY ACCORDING TO EN 61000 (INDUSTRY)	
Basic standard CE	Fulfilled requirements according to EN 61000 (CE) (Interference immunity of industrial environment)
Electrostatic discharge EN 61000-4-2 Contact discharge Air discharge Comment	4 kV 8 kV Criterion B
Electromagnetic HF field EN 61000-4-3 Frequency range Test field strength Frequency range Test field strength Comment	80 MHz ... 1 GHz 10 V/m 1.4 GHz ... 2 GHz 3 V/m Criterion A
Fast transients (Burst) EN 61000-4-4 Test voltage Comment	2 kV Criterion A
Surge voltage load (Surge) EN 61000-4-5 Test voltage L-N Test voltage L-PE, N-PE Comment	±0.5 kV ±1 kV Criterion A
Power frequency magnetic field immunity EN 61000-4-8 Test level Comment	30 A/m Criterion A

EMISSION ACCORDING TO EN 55016-2-3 (DOMESTIC)	
Basic standard CE	Fulfilled requirements according to EN 55016-2-3 (CE) (Domestic)
Conducted emission from the power port EN 55016-2-3 Frequency range Comment	150 kHz–30 MHz Conform
Electric field radiated emission EN 55016-2-3 Frequency range Comment	30 MHz–1 GHz Conform

LEGEND	
Criterion A	Normal operating behavior within the defined limits.
Criterion B	Temporary impairment of the operating behavior, that is corrected by the device itself.

D8 Drawing

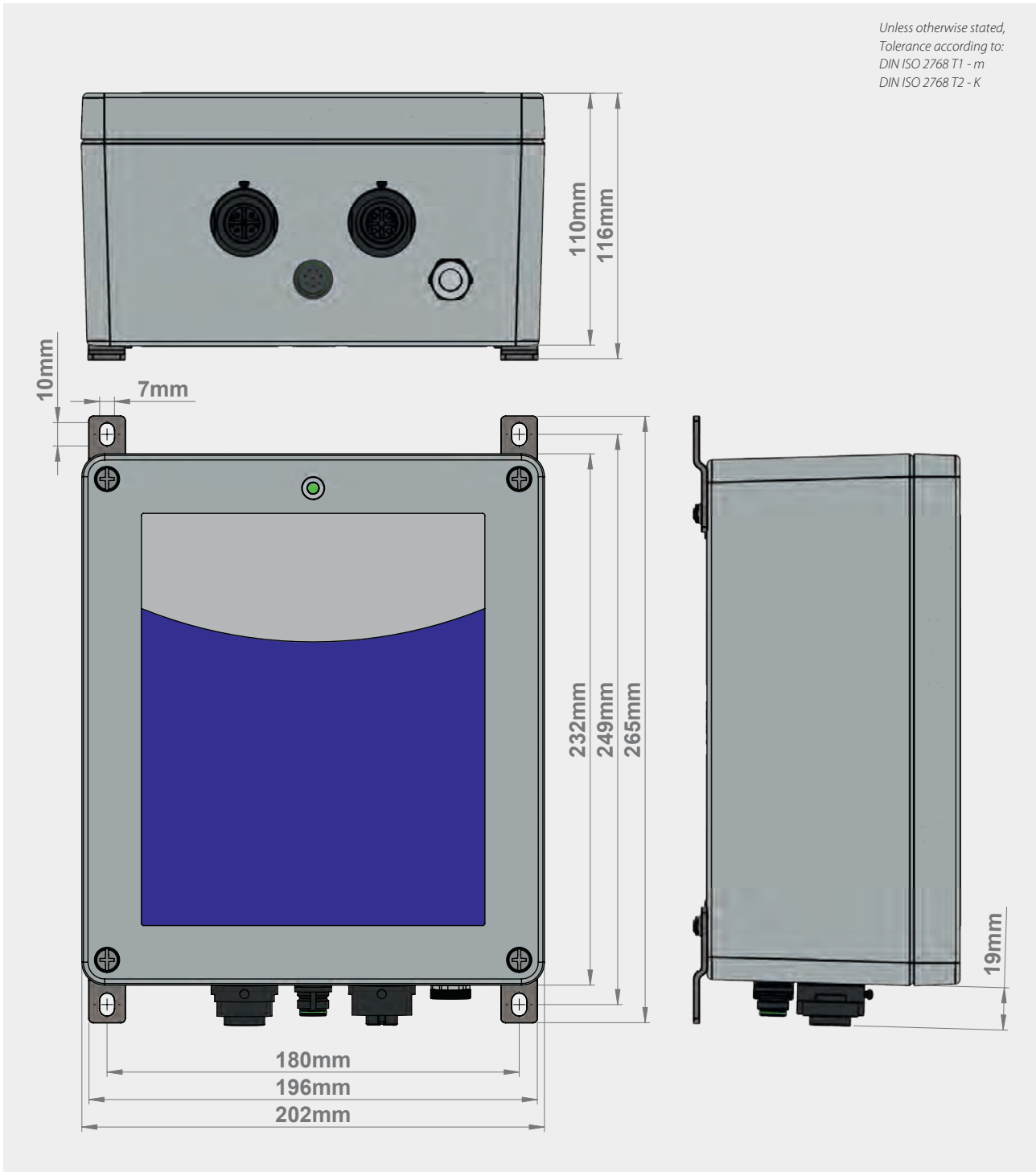

E Name / Address / Support E-Mail / Phone number of the manufacturer

Bicker Elektronik GmbH · Ludwig-Auer-Straße 23 · 86609 Donauwörth · Germany

E-Mail: support@bicker.de · Tel.: +49 (0) 906 70595-0

F General Data

F1 Assembly and installation advice



Installation and operation of this device is only allowed to be executed by a qualified

electrician! The application has to be separated from any power during the mounting process.

The connector cables have to be correctly locked with the device connections and may only be screwed hand-tight (max. 0.5 Nm). Pay attention to correct polarity! Before commissioning, the connections must be checked for correctness. The interface cable is plugged to the multi-

functional interface using snap-in technology and has to lock with it accordingly. If a cable is not plugged in, the connector has to be covered with a suitable protective cap (not included in the scope of delivery, optionally available, article number „PSZ-1104“).

The two functional earth strands (green/yellow) of the input and output lines are internally connected to both housing parts, the four mounting brackets and the input and output GND (V_{IN-} / V_{OUT-}) of the UPS board as well as PIN 3 and 4 of the USB connection.

F2 Convection and installation position

It is recommended to mount the device vertically (on edge) or „horizontally“ on a suitable wall or surface in order to achieve the best possible convection. Another installation position should be avoided if possible, as operation up to the highest ambient temperature can not be guaranteed. Although the device can basically be operated without external air convection, care should still be taken to ensure that there is enough convection around it so that the generated heat can be dissipated. Care should be taken not to install it in or at slim and narrow places such as niches, corners, crevices or the like, as this can cause it to be heated by other sources or devices and thus drastically reduce the service lifetime or errors and dangers can occur.

A distance of at least 100 mm (10 cm) in all directions from the housing wall to other, neighboring devices should be maintained.

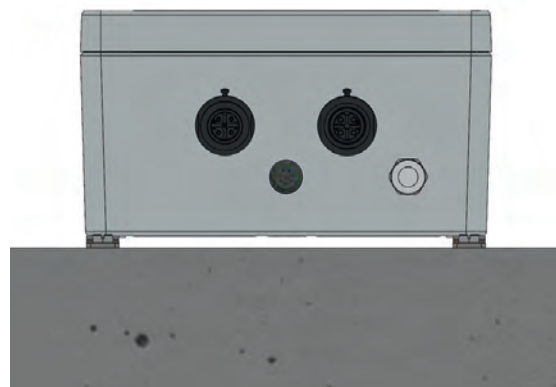
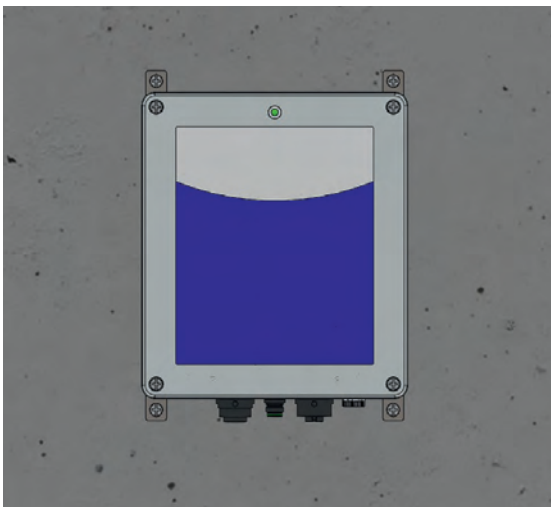

The devices comply with the IP protection class 65/67.

F3 Description of connectors

INPUT



PIN	FUNCTION
1	Vin +
2	Vin - (GND)
3	n.a
	FE

OUTPUT



PIN	FUNCTION
1	Vout +
2	Vout - (GND)
3	n.a
	FE

MULTIFUNCTIONAL INTERFACE



PIN	FUNCTION
1	Relay +
2	Relay -
3	TXD
4	RXD
5	V+
6	Data+
7	Data-
8	Common GND / Shield

F4 Dimensioning the upstream power supply

Ensure that the upstream power supply is correctly dimensioned to guarantee the charging process of the batteries and the correct functioning of the application. For charging the energy storage even at higher load must be taken care of.

The input has to be supplied from a SELV or PELV power supply. In order to operate the UPS devices with complete functionality, the upstream power supply has to provide at least the following sizes and use **no** constant current function.

UPSI-1208IP-23U: 12 V/10 A, app. 120 W

UPSI-2406IP-24U: 24 V/7.5 A, app. 180 W

UPSI-2406IP-26U: 24 V/7.5 A, app. 180 W

UPSI-1208IP-23UW: app. 125 W

UPSI-2406IP-24UW: app. 190 W

UPSI-2406IP-26UW: app. 170 W

If less load than the maximum load is required at the output, the voltage supply can be dimensioned according to the following tables (column 3 in each case).

UPSI-1208IP-23U / UPSI-2406IP-24U / UPSI-2406IP-26U:

UPSI-1208IP-23U		
I_{LOAD} [A]	I_{CHARGE} [A]	I_{IN-MIN} [A]
0	3.9	4
1	3.6	5
2	3.2	6
3	2.9	6.5
4	2.4	7
5	2.1	7.5
6	1.7	8
7	1.4	9
8	1.0	10

UPSI-2406IP-24U		
I_{LOAD} [A]	I_{CHARGE} [A]	I_{IN-MIN} [A]
0	2.4	3
1	2.25	3.5
2	2.0	4
3	1.75	5
4	1.6	6
5	1.4	7
6	1.1	7.5

UPSI-2406IP-26U		
I_{LOAD} [A]	I_{CHARGE} [A]	I_{IN-MIN} [A]
0	2.25	2.5
1	2.1	3.5
2	2.0	4
3	1.7	5
4	1.6	6
5	1.4	7
6	1.1	7.5

UPSI-1208IP-23UW / UPSI-2406IP-24UW / UPSI-2406IP-26UW:

In these devices with a wide range input, an additional DC/DC converter is connected upstream of the UPS, so that a continuous specification of the input current I_{IN-MIN} is not possible. The input voltage can vary between 7/8 to 36 V DC, depending on this the input current changes. Added to this is the heat loss from the DC/DC converter ($P_{DC/DC}$) of max. 10 % $P_{CHARGE+LOAD}$.

This means that only the input power (P_{IN-MIN}) can be specified:

UPSI-1208IP-23UW				
I_{LOAD} [A]	P_{LOAD} [W]	P_{CHARGE} [W]	$P_{CHARGE+LOAD}$ [W]	P_{IN-MIN} [W] required
0	0	~48	~48	55
1	12	~42	~54	60
2	24	~40	~64	70
3	36	~35	~71	80
4	48	~31.5	~79	90
5	60	~27	~87	100
6	72	~23	~95	105
7	84	~20	~104	115
8	96	~15.6	~111.5	125

UPSI-2406IP-24UW				
I_{LOAD} [A]	P_{LOAD} [W]	P_{CHARGE} [W]	$P_{CHARGE+LOAD}$ [W]	P_{IN-MIN} [W] required
0	0	~58	~58	70
1	24	~54	~78	85
2	48	~48	~96	110
3	72	~46	~118	130
4	96	~44	~140	155
5	120	~42	~162	180
5.4	130	~40	~170	190
6	144	0	144	160*

UPSI-2406IP-26UW				
I_{LOAD} [A]	P_{LOAD} [W]	P_{CHARGE} [W]	$P_{CHARGE+LOAD}$ [W]	P_{IN-MIN} [W] required
0	0	~55	~55	65
1	24	~50	~74	85
2	48	~48	~96	110
3	72	~46.5	~118.5	130
4	96	~45	~141	155
4.6	110	~43.5	~153.5	170
5	120	0	120	135*
6	144	0	144	160*

*With the two devices UPSI-2406IP-24UW and UPSI-2406IP-26UW, a load more than 5.4 A or 4.6 A is possible if the energy storage device is fully charged at this time (SOC = 100 %) and charging no longer takes place.

F5 Connecting diagram

Several possibilities:
USB / RS232 / Relay

A special accessory cable
for each function



CONNECTING ORDER

1. APPLICATION (V_{OUT})
2. DC SOURCE (V_{IN})
3. INTERFACE CABLE (ACCESSORY)

Dismantling order reverse to connection!



V_{IN}/V_{OUT} - ATTENTION!

1. Note polarity!
2. Pay attention to the maximum cable length. The supplied cables should not be lengthened because if the cables are too long, an unintentional power fail may be triggered (e.g. due to a voltage level change in the event of load drop).

WIRING DIAGRAM: UPSI-1208IP-23U / 2406IP-24U / 2406IP-26U

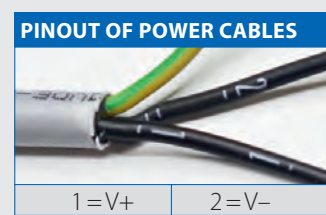
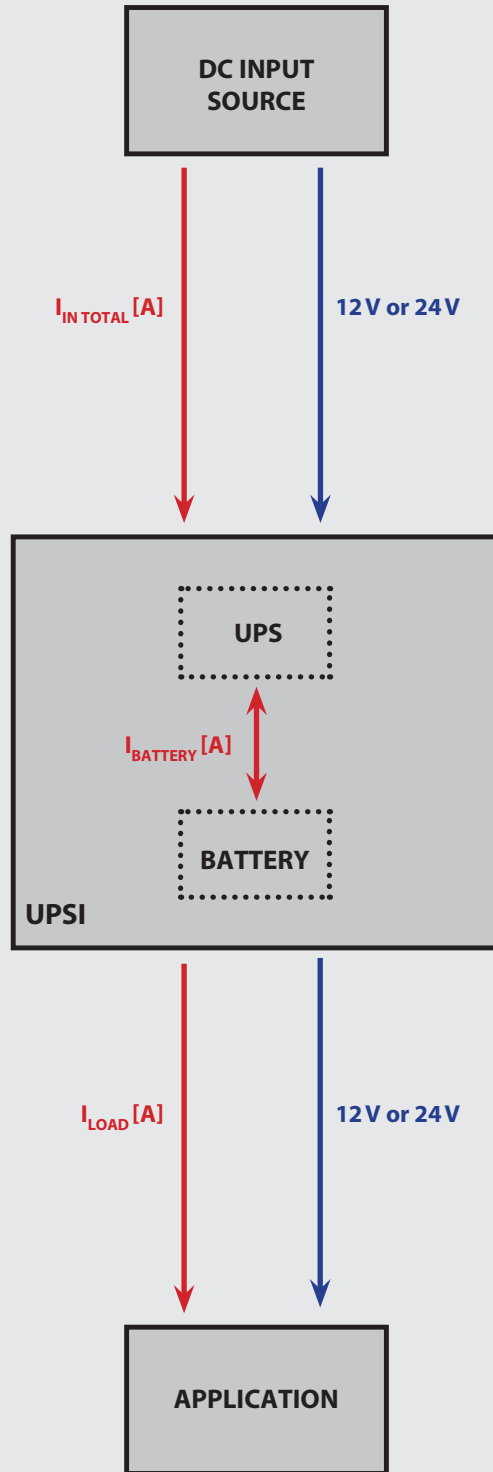

WIRING DIAGRAM: UPSI-1208IP-23UW / 2406IP-24UW / 2406IP-26UW

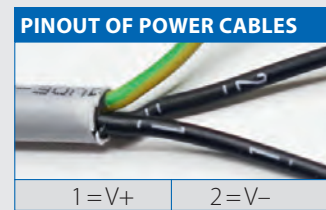
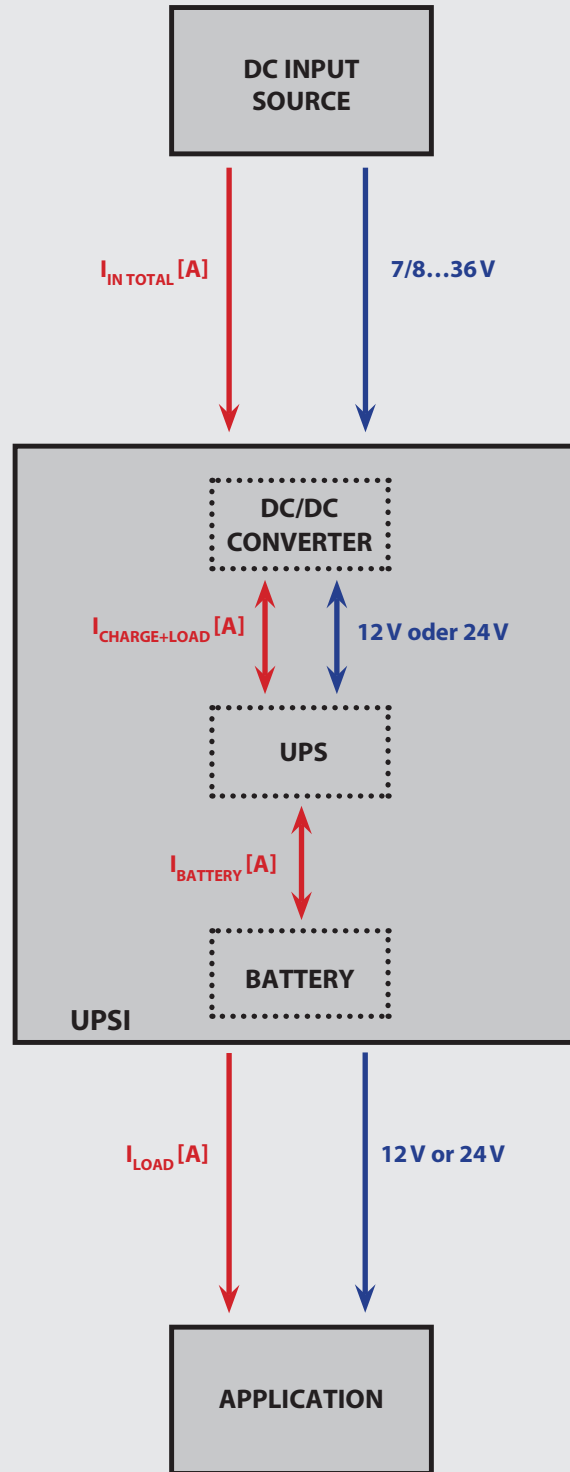

F6 Initial operation

The correct installation of the UPS has to be ensured.

It is started by connecting the supply voltage:

For UPSI-1208IP-23U / UPSI-2406IP-24U / UPSI-2406IP-26UW:

If a voltage more than 11.5 V or 22.5 V is connected via the input lines, the energy storage device is queried and transmits its data. The UPS sets the corresponding end-of-charge voltage and releases the pack. After that the charging of the energy storage starts. The applied voltage at the input of the UPS is passed through to the output, reduced by a current-dependent voltage drop. The device charges the energy storage and monitors the upstream voltage thresholds at the input (UPS function).

For UPSI-1208IP-23UW / UPSI-2406IP-24UW / UPSI-2406IP-26UW:

If a voltage, more than the values specified in Part D „Technical data“ of the respective device, is applied via the input lines, the integrated DC/DC converter starts operation and converts the applied input voltage to a constant 12V or 24V. This voltage is passed through to the UPS, the energy storage is queried and its data is transmitted. The UPS sets the corresponding end-of-charge voltage and releases the pack. After that the charging of the energy storage starts. The applied voltage at the input of the UPS is passed through to the output. The device charges the energy storage and monitors the upstream voltage thresholds at the input (UPS function).

It must be ensured that the source supplies enough current to guarantee the charging process (see chapter F4 „Dimensioning the upstream power supply“).



Even after disconnecting the upstream source and also no voltage is measurable at the output, the UPS can be still powered by the energy storage.

F7 Overview connector / Counterpart with description / Scope of delivery

CONNECTOR	PART NO. HOUSING END	PART NO. CABLE END
V _{IN}	Binder 09422315004	Binder 9902100004
V _{OUT}	Binder 09422415004	Binder 9902090004
Multifunctional Interface	Binder 9991280008	Binder 9991250008

SCOPE OF DELIVERY	
QUANTITY	DESCRIPTION
1x device	UPSI-1208IP-23U, UPSI-1208IP-23UW, UPSI-2406IP-24U, UPSI-2406IP-24UW, UPSI-2406IP-26U or UPSI-2406IP-26UW
1x	V _{IN} cable, 3x 2.5 mm ² (inclusive FE), length 3 m, open end
1x	V _{OUT} cable, 3x 2.5 mm ² (inclusive FE), length 3 m, open end
1x	USB cable, length 3 m, with type A connector

F8 Accessories

PSZ-1108	Relay Cable
PSZ-1109	RS232 Cable
PSZ-1110	USB Cable
PSZ-1104	Cover multifunctional interface

F9 Charging time

Charging times depend on energy storage, input voltage and the load current.

F10 Reverse polarity / Overcurrent / Short circuit

Reverse polarity (**ONLY** at UPSI-1208IP-23U / UPSI-2406IP-24U / UPSI-2406IP-26U):

The device has active reverse polarity protection at the input if the input strands are connected with reverse polarity while the device is still switched off (e.g. during commissioning). If the device operates in battery mode and the input strands are connected with reverse polarity, no reverse polarity protection is given.

Overcurrent:

If the load current at the output is too high, the device switches it off. For maximally allowed current values and peak current values refer to chapter D „Technical Data“. The status LED indicates the error status by means of a very rapid flashing sequence. A restart attempt occurs every 10 seconds in normal mode. During battery mode there is no restart attempt.

Short circuit:

In the event of a short-circuit at the output of the UPS, the output is immediately disconnected (<5 ms). The status LED indicates the error status by means of a very rapid flashing sequence. A restart attempt occurs every second in normal mode (non-latch). During battery mode there is no restart attempt. The impact of a short-circuit to the device depends on length and diameter (impedance) of the output wiring. In case of a short-circuit directly at the device output a damage of the device can occur.

F11 Backup time in battery mode

The nominal backup times can be found within the technical data of this user manual or the user manuals/datasheets of the used energy storages. At extreme low or high temperatures a reduction of the nominal backup times can occur.

F12 Behaviour in case of exceeding maximum backup time

When the given buffering times are exceeded, the output is separated on the basis of the discharge voltage of the corresponding energy storage (total discharge protection).

With supercapacitors in particular, an additional switch-off threshold can take effect if the discharge current of the energy storage device is too high (>15 A). This can occur at very high load currents at the output of the UPS. The lower the voltage of the energy storage device decreases, the higher the discharge current so that a constant power is ensured at the output of the UPS.

If the allowable output current during battery mode exceeds more than 70%, the converter switches off first, without separating the output immediately. In this case, the voltage at the output of the UPS can drop significantly below 12V or 24 V. This condition should be avoided by shutting down the system in time.

F13 Status LED

Valid from firmware version 2.1.19

MAIN STATES		
	Always on	Status: mains voltage >> Mains voltage is present.
	1 Hz flash (1 s on, 1 s off)	Status: Battery mode >> Mains voltage is not present.
INTERNAL STATES		
	1 x flash (LED is off briefly), pause 2 s	Status: Battery start* >> Manual start from the battery by pressing the BS button.
	2 x flash (LED is off briefly), pause 2 s	Status: Capacity not reached >> Capacity is required. Output is only activated when the battery is charged to set SOC.
	3 x flash (LED is off briefly), pause 2 s	Status: Shutdown >> UPS has received a shutdown signal and is waiting until the set load sensor value has fallen below.
	4 x flash (LED is off briefly), pause 2 s	Status: Reboot >> Output is deactivated and time until reboot runs (Reboot phase).
BATTERY FAILURES		
	1 x flash (LED is off a long time), pause 2 s	Status: No battery detected
	2 x flash (LED is off a long time), pause 2 s	Status: Battery overvoltage >> Charge voltage at battery is too high, battery is deactivated.
	3 x flash (LED is off a long time), pause 2 s	Status: Battery overcurrent >> Charge current at battery is too high, battery is deactivated.
	4 x flash (LED is off a long time), pause 2 s	Status: Battery temperature failure >> Battery temperature sensor was not detected or battery temperature is too high or low.
UPS FAILURES		
	Quick flashing without pause	Status: UPS failure >> Output current too low, UPS is deactivated. >> Overcurrent at output (charge current too high), output is deactivated >> Short circuit at output, output is deactivated >> Internal failure, UPS is deactivated.

* Not available with UPSI-IP-2 series

F14 Shutdown diagram

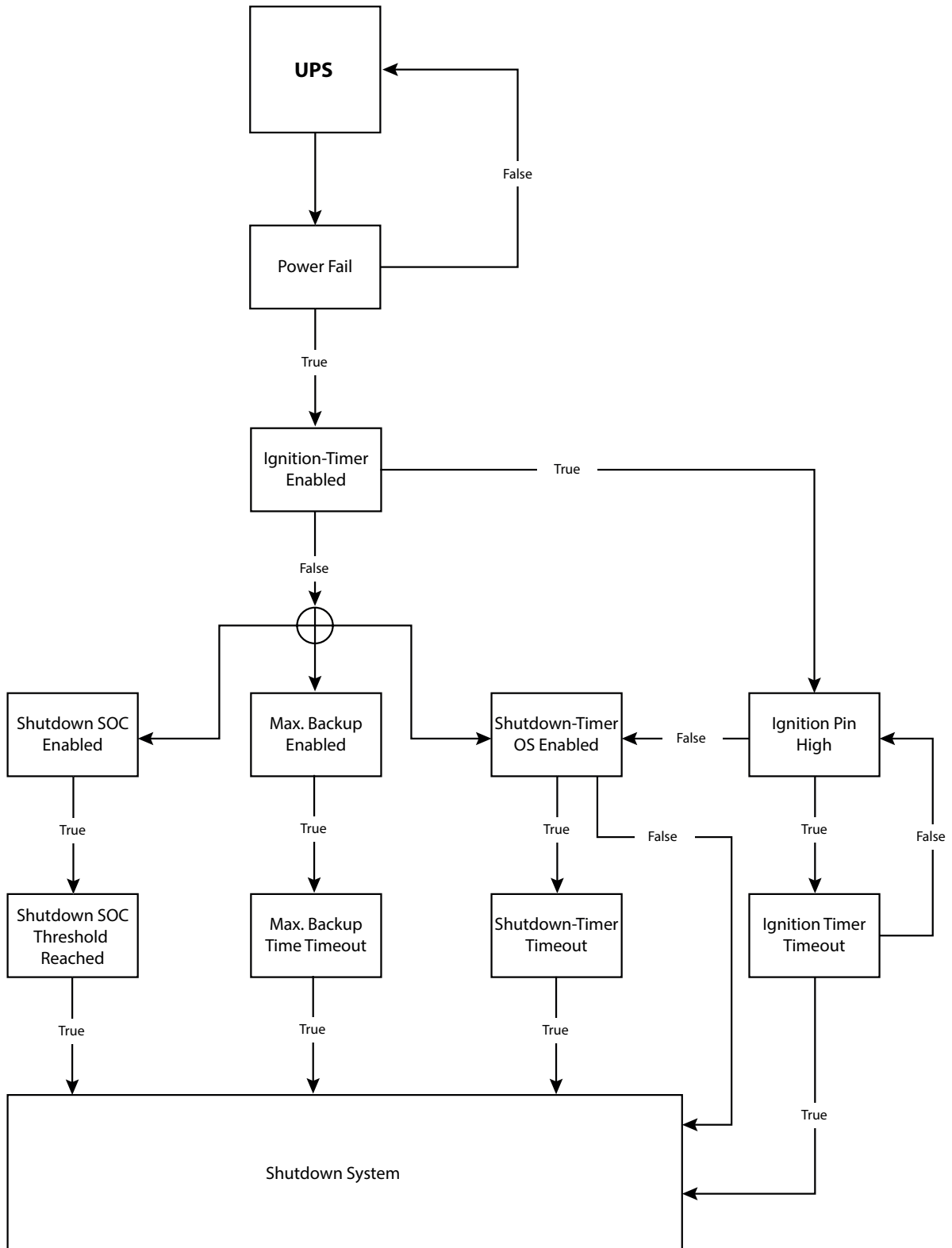

F15 Recommendations for a long UPS service life

Over time, the capacity of the Supercaps decreases and the ESR (equivalent series resistance) increases. However, EOL is often defined as a reduction in capacity to 70 % and a doubling of the ESR. An important aspect for the aging of the Supercaps is the end-of-charge voltage and the operating temperature. LiFePO₄ batteries also age over time depending on cycles, operating temperature and the level of the end-of-charge voltage. The end-of-charge voltages are optimized so that they are at an optimum between service life and performance.

To extend the lifetime of the system, the device should not be placed near sources of heat and should be placed within good air-circulation. When using a LiFePO₄ battery, a larger capacity than actually required should always be used. The less deep the packs are discharged, the longer the service life lasts.

F16 Maintenance

The UPS contains no serviceable parts. In case of a malfunction the upstream power source has to be disconnected and cables have to be removed. Use a dry cloth for cleaning!



F17 Disposal

Electric and electronic devices must not be disposed with domestic waste! Please consider to each country's own regulation about recycling and disposal of used batteries at the end of their lifetime or resending to any recycling organization.

F18 Disclaimer

We, the Bicker Elektronik GmbH, have checked the contents of this document for compliance with the hardware and software described. Nevertheless, deviations can not be ruled out, so we assume no liability for the complete agreement. The information in this publication is checked regularly, necessary corrections are included in the updated versions.

Suggestions for improvement as well as tips and criticism are always welcome.

F19 Preventive measures and rules when operating the UPS system

The voltage drop of the lines has to be kept in mind! The maximum charge current can cause huge voltage drops if too long supply lines are used. If the voltage drop is too high a shortfall of the threshold values is possible and a not intended Power Fail could be caused. With maximum load the voltage at the input of the device must not undercut the respective minimum value. Especially with the -XXUW versions with additional wide-range input, a low input voltage in combination with a high (even short-term) charge current can lead to a temporary high voltage drop!

Even after the upstream supply has been disconnected, the device continues to run for some time after the shortfall of the load sensor (setting of a threshold value for current: currents below this value will be classified as „system off“ (no load)).

A short direct at the output of the device can cause damage or destruction of the UPS. In the event of a fault, electrolytes can escape in liquid and gaseous form.

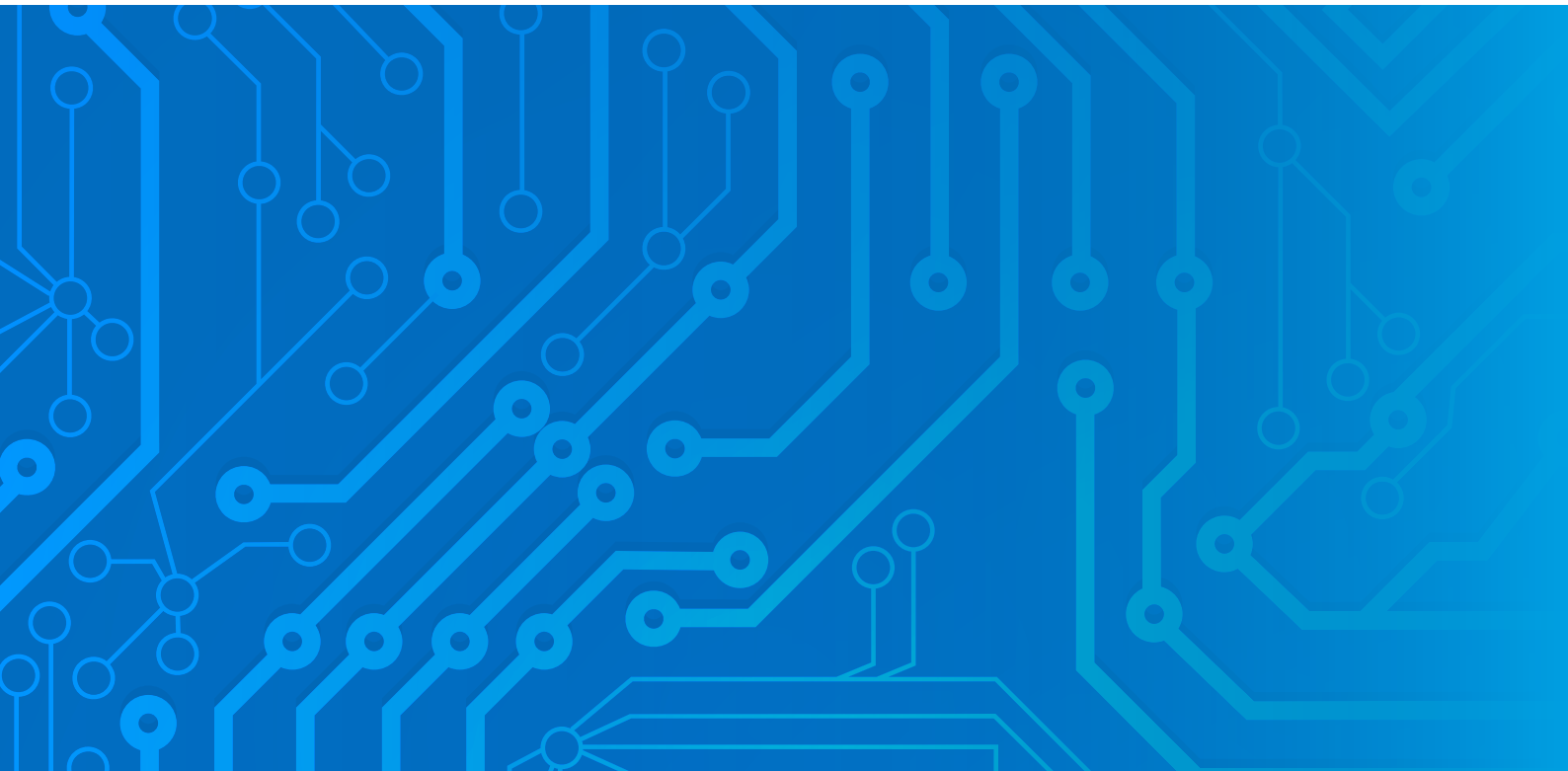

Note: Subject to errors and technical modifications!
Windows® is a registered trademark of the Microsoft Corp.
Status as at: 22.02.2023 – Revision 1-3



Bicker Elektronik GmbH
Ludwig-Auer-Straße 23
86609 Donauwörth · Germany
Tel. +49 (0) 906 70595-0
Fax +49 (0) 906 70595-55
E-Mail info@bicker.de
www.bicker.de