



## RCT

Torsionally Stiff Flange Couplings for Pump Drives

[www.reich-kupplungen.com](http://www.reich-kupplungen.com)



SIMPLY **POWERFUL.**





## D2C – Designed to Customer

The guiding principle of Designed to Customer is the recipe for success behind REICH. In addition to the catalogue products, we supply our customers with couplings developed to their specific requirements. The designs are mainly based on modular components to provide effective and efficient customer solutions. The special nature of our close cooperation with our partners ranges from; consulting, development, design, manufacture and integration to existing environments, to customer-specific production, logistics concepts and after-sales service - worldwide.

This customer-oriented concept applies to both standard products and production in small batch sizes.

The company policy at REICH embraces, first and foremost, principles such as customer satisfaction, flexibility, quality, prompt delivery and adaptability to the requirements of our customers.

REICH supplies not only a coupling, but a solution:

Designed to Customer – SIMPLY **POWERFUL**.

**D2C**  
Designed to Customer



# RCT

## Contents

## Coupling Information

- 04** General Technical Description

---

- 05** Advantages

---

- 06** Technical Layout

---

- 07** General Technical Data

---

- 08** Selection of the Coupling Size

---

- 11** Standard Hub Splines

---

- 12** Permissible Shaft Displacement

---

- 13** Bellhousing Flange PTF

---

- 14** Data Required for Coupling Size Selection

## Dimension Tables

- 09** Type RCT...F2

---

- 10** Type RCT...F2S

# RCT

## General Technical Description

### RCT

## Torsionally Stiff Flange Couplings for Pump Drives

With RCT couplings REICH offers an optimal drive solution for the connection of diesel engines to hydraulic pumps. Due to the torsionally stiff design of the RCT coupling, critical resonances can be shifted into the range above the operating speeds. This enables sub critical operation of the drive without passing through detrimental torsional vibration amplitudes.

The RCT coupling, like the decade-long proven ARCUSAFLEX® coupling, is designed as an axially pluggable flange coupling. The coupling element consists of a robust metal inner body with a thin rubber coating that effectively dampens torque shocks. In addition, small axial, radial and angular displacements which are common to flanged hydraulic drives can be compensated for.

Numerous standardized tooth profiles ensure a backlash-free clamping connection between the RCT coupling and the pump shaft. The coupling flanges are matched to SAE flywheel dimensions.

As a supplementary service, REICH also offers a multitude of bellhousing flanges through which the vast majority of combustion engines and hydraulic pumps can be connected.

REICH can also develop an optimised solution for non-standard designs following the principle “D2C - Designed to Customer”.



## RCT

Nominal torques from 300 Nm to 5 000 Nm

## RCT Advantages

### Salient features and advantages of the RCT coupling:

- Sub critical operation through high torsional stiffness
- Vibration and torque shock damping through flexible rubber coating
- High torque transmission capacity, fail-safe
- Ambient temperatures from -25 °C to +100 °C
- Compact, robust, maintenance-free
- Ease of assembly thanks to the plug-in axial design
- Backlash-free shaft-hub connection
- Compensation of axial, radial and angular displacements
- Multiple spline options for the connection to the pump shaft
- Bellhousing flanges for almost any mounting situation

# RCT

## Technical Layout

### RCT layout and materials

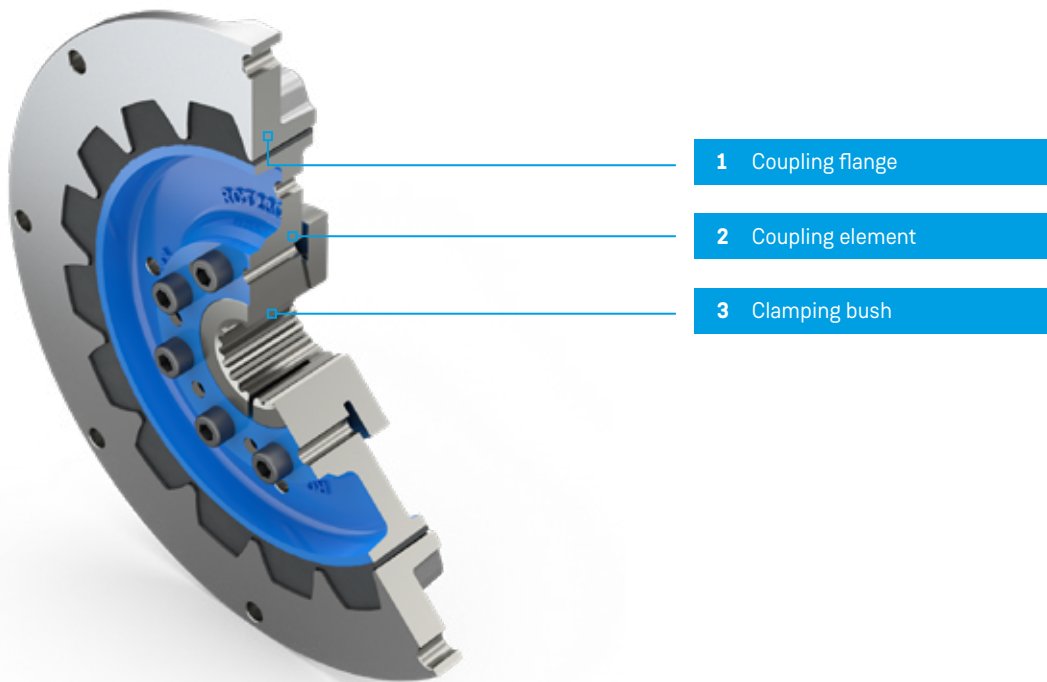

### Material Overview

Part No.	Designation	Materials
1	Coupling flange	Aluminium
2	Coupling element	Cast iron/rubber
3	Clamping bush	Steel

### Technical Note

The technical data applies only to the complete coupling or the corresponding coupling elements. It is the customer's/user's responsibility to ensure there are no inadmissible loads acting on any of the components. In particular, existing connections, e.g. bolted connections, must be checked with regard to the torques to be transmitted. If necessary, further measures, such as additional reinforcement with pins, may be necessary. It is the customer's/user's responsibility to make sure the dimensioning of the shaft and keyed or other connection, e.g. shrinking or clamping connection,

is correct. All components that can rust are protected against corrosion as standard.

REICH have an extensive range of couplings and coupling systems to cover nearly every drive configuration. Customized solutions can be developed and manufactured even in small batches or as prototypes. In addition calculation programs are available for all necessary dimensioning.

# RCT

## General Technical Data



### Standard Type

Coupling size	Nominal torque $T_{KN}$ [Nm]	Maximum torque $T_{Kmax}$ [Nm]	Continuous fatigue torque $T_{KW}$ (10 Hz) [Nm]	Dynamic torsional stiffness $C_{T dyn}$ [Nm/rad]				Relative damping $\psi$	Flange size SAE J 620	Maximum speed $n_{max}$ [min <sup>-1</sup> ]	Max. shaft displacement	
				$C_{T dyn}$							radial $\Delta K_r$ [mm]	angular $\Delta K_w$ [°]
				0.25 $T_{KN}$	0.5 $T_{KN}$	0.75 $T_{KN}$	1.0 $T_{KN}$					
30	300	900	150	45	80	110	130	1.6	6.5	4200	±0.5	±0.5
									7.5	4200		
									8	4200		
65	650	1950	325	115	215	280	325	1.6	8	4200	±0.5	±0.5
									10	3600		
									11.5	3500		
120	1200	3600	600	265	510	940	1110	1.6	10	3600	±0.5	±0.5
									11.5	3500		
									14	3000		
230	2300	6900	1150	675	1220	1810	2130	1.6	10	3600	±0.5	±0.5
									11.5	3500		
									14	3000		
500	5000	15000	2500	2200	4000	5900	6950	1.6	14	3000	±0.5	±0.5

### Coupling and bellhousing flange

Coupling size	Flange version	SAE flywheel connection	Total length of coupling	with bellhousing flange	SAE engine housing connection	SAE pump connection	Length of bellhousing flange	2-hole or 4-hole flange
RCT 120	F2.	11.5.	63.	PTF	3 -	C.	45.	4

Designation: RCT 120 F2. 11.5. 63. PTF 3-C. 45. 4

### Bore

Tooth profile according to ANSI B92.1 or DIN 5480	Toothing size	Toothing number	Toothing length
ANSI B92.1	- 16/32 -	21	L=54
DIN 5480	N45x2x30x	21	L=54

Designation: ANSI B92.1 - 16/32 - 21T L=54 or DIN 5480 N45x2x30x21 L=54

# RCT

## Selection of the Coupling Size

Usually the layout of the RCT coupling is based on the drive torque.  
A general safety factor of  $S = 1.1$  to  $1.3$  should be applied. Torsional vibration analysis can be undertaken on request.

**In selecting the coupling size the following should be satisfied:**

 The **nominal torque capacity of the coupling**  $T_{KN}$  shall be at least equal to the drive torque while taking the layout factors into account.

$$T_{KN} \geq T_{AN} \cdot S$$

 Calculate the **driving torque**  $T_{AN}$   
Given a driving power  $P_{AN}$  and a coupling speed  $n_{AN}$ , the driving torque is calculated as follows:

$$T_{AN} [\text{Nm}] = 9550 \frac{P_{AN} [\text{kW}]}{n_{AN} [\text{min}^{-1}]}$$



# RCT

Type RCT...F2.

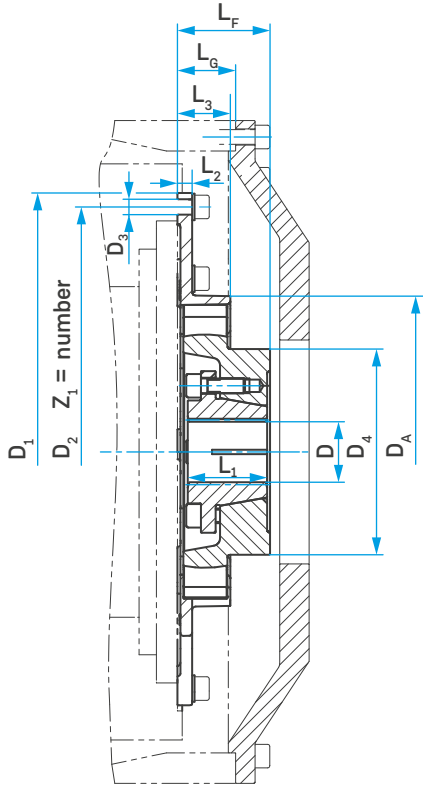

Long type Fig. 1

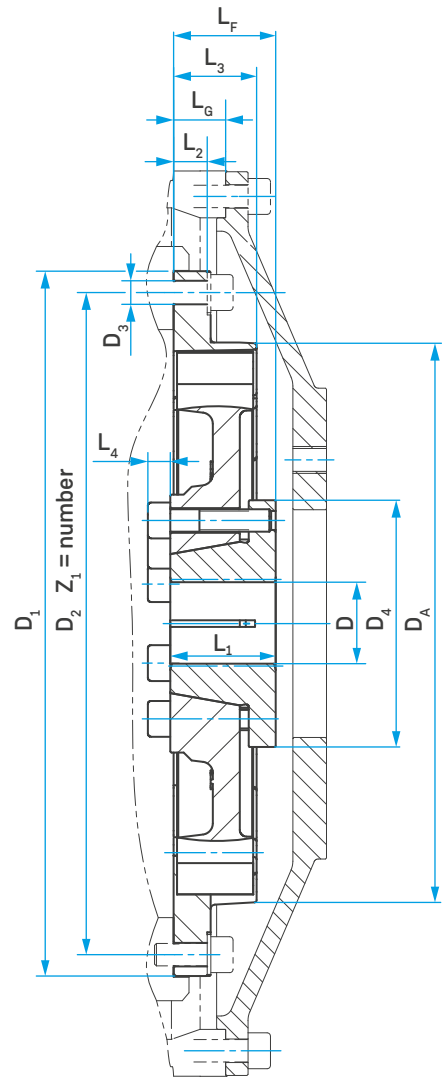

Long type Fig. 2

## Coupling details

Coupling size	Fig.	Flange connections						D max. [mm]	DA [mm]	D4 [mm]	L1 [mm]	L2 [mm]	L3 [mm]	L4 [mm]	LF [mm]	LG [mm]	J1 outside [kgm <sup>2</sup> ]	J2 inside [kgm <sup>2</sup> ]	Total mass [kg]			
		SAE J620	D1 [mm]	D2 [mm]	D3 [mm]	Z1																
30	1	6.5	215.9	200.0	8.5	6	40.0	137.0	76.0	44.0	10.0	30.0	-	51.0	30.2	0.0027	0.002	2.1				
		7.5	241.3	222.3	8.5	8													±2.0	62.0	0.0046	2.2
		8	263.5	244.5	10.5	6																
65	1	8	263.5	244.5	10.5	6	46.0	167.0	105.0	50.0	10.0	34.0	-	58.0	62.0	0.0060	0.007	4.0				
		10	314.3	295.3	10.5	8													±2.0	39.6	0.0153	4.5
		11.5	352.4	333.4	10.5	8																
120	1	10	314.3	295.3	10.5	8	51.0	212.0	140.0	54.0	10.0	36.0	-	63.0	53.8	0.0133	0.025	7.5				
		11.5	352.4	333.4	10.5	8													±2.0	39.6	0.0170	7.6
230	2	10	314.3	295.3	10.5	8	51.0	250.0	110.0	47.0	16.5	37.0	10.0	45.5	53.8	0.0235	0.04	8.0				
		11.5	352.4	333.4	10.5	8													±1.5	25.4	0.1230	10.6
		14	466.7	438.2	13.0	8																
500	2	14	466.7	438.2	13.0	8	80.0	357.0	150.0	47.0	16.5	40.0	10.0	47.0	25.4	0.1110	0.18	17.8				
														±3.0								

# RCT

Type RCT...F2S.

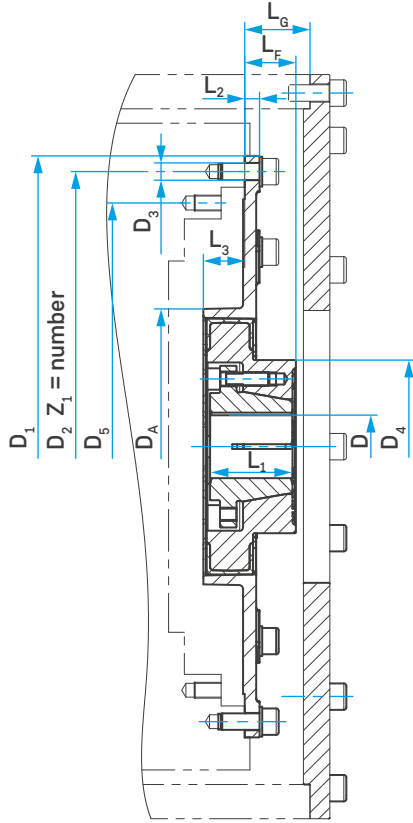

Short type Fig. 1

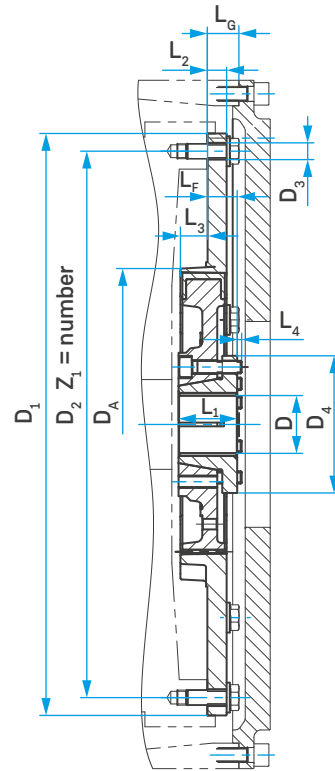

Short type Fig. 2

## Coupling details

Coupling size	Fig.	Flange connections						D max. [mm]	DA [mm]	D4 [mm]	L1 [mm]	L2 [mm]	L3 [mm]	L4 [mm]	LF [mm]	LG [mm]	J1 outside [kgm <sup>2</sup> ]	J2 inside [kgm <sup>2</sup> ]	Total mass [kg]
		SAE J 620	D1 [mm]	D2 [mm]	D3 [mm]	Z1													
30	1	6.5	215.9	200.0	8.5	6	40.0	137.0	76.0	44.0	9.0	21.0	-	28.0	30.2	0.0027		2.1	
		7.5	241.3	222.3	8.5	8								±2.0	30.2	0.0041	0.002	2.2	
		8	263.5	244.5	10.5	6								62.0	0.0046		2.2		
65	1	8	263.5	244.5	10.5	6	46.0	167.0	105.0	50.0	9.0	25.0	-	31.0	62.0	0.0060		4.0	
		10	314.3	295.3	10.5	8								±2.0	53.8	0.0105	0.007	4.3	
		11.5	352.4	333.4	10.5	8								39.6	0.0153		4.5		
120	1	10	314.3	295.3	10.5	8	51.0	212.0	140.0	54.0	9.0	27.0	-	34.0	53.8	0.0133	0.025	7.5	
		11.5	352.4	333.4	10.5	8								±2.0	39.6	0.0170		7.6	
230	2	10	314.3	295.3	10.5	8	51.0	250.0	110.0	47.0	15.5	21.5	≈3	24.0	53.8	0.0235		8.0	
		11.5	352.4	333.4	10.5	8								±1.5	39.6	0.0392	0.04	8.6	
		14	466.7	438.2	13.0	8								25.4	0.1230		10.6		
500		on request																	

**i** The short design requires sufficient installation space in the flywheel; feasibility must be checked by the customer

# RCT

## Standard hub toothing

### Preferred toothing

	Toothing size	Coupling size				
		RCT 30	RCT 65	RCT 120	RCT 230	RCT 500
ANSI B92.1 class 6	16/32 - 9T	•				
	16/32 - 13T	•	•			
	16/32 - 15T	•	•	•	•	
	12/24 - 14T	•	•	•	•	
	16/32 - 23T	•	•	•	•	
	12/24 - 17T	•	•	•	•	
	16/32 - 27T		•	•	•	•
	8/16 - 13T		•	•	•	•
	8/16 - 15T			•	•	•
	8/16 - 17T			•	•	•
DIN 5480 - 9H	25x1.5x18	•	•			
	30x2x14	•	•	•	•	
	35x2x16	•	•	•	•	
	40x2x18	•	•	•	•	
	45x2x21		•	•	•	
	50x2x24			•	•	•
	55x2x26			•	•	•
	60x2x28					•
70x3x22					•	

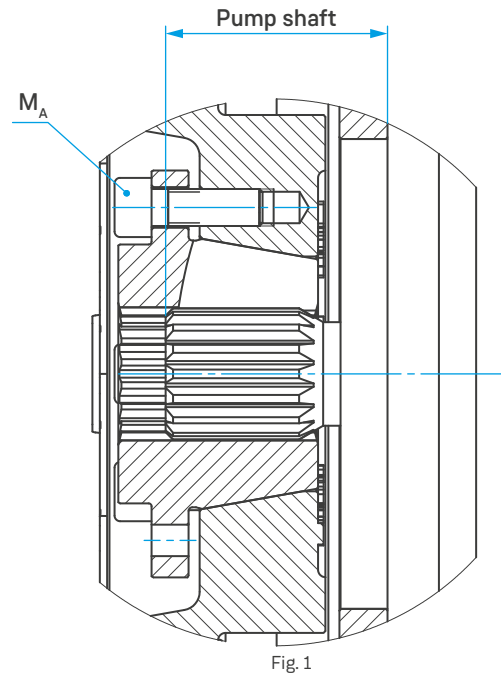

**i** Alternative tooth profiles and finish bore with keyway on request

### Tightening torques $M_A$

Coupling size		RCT 30	RCT 65	RCT 120	RCT 230	RCT 500
Bolt size		M6	M8		M10	
Tightening torques $M_A$	[Nm]	14	35		69	

# RCT

## Permissible shaft displacement

The permissibility of major shaft displacements depends on a number of factors such as coupling size, shore hardness of the element, operating speed and torque load of the coupling. The reference values listed below refer to an operating speed of  $\approx 1500 \text{ min}^{-1}$ . Precise alignment prevents premature wear of the rubber element. Observe the operating instructions.

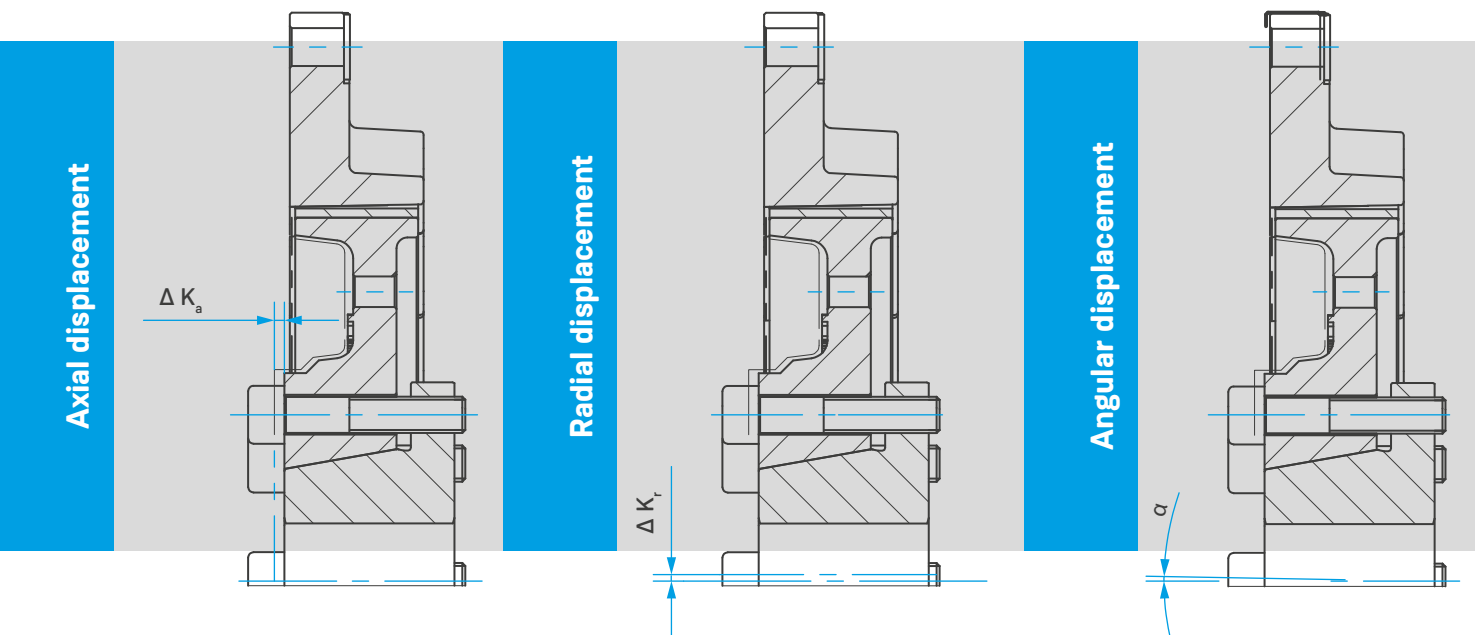

### Technical specifications

Coupling size			RCT 30	RCT 65	RCT 120	RCT 230	RCT 500
Max. permissible axial displacement	$\Delta K_a$	[mm]	$\pm 2.0$	$\pm 2.0$	$\pm 2.0$	$\pm 1.5$	$\pm 3.0$
Max. permissible radial displacement	$\Delta K_r$	[mm]	$\pm 0.5$	$\pm 0.5$	$\pm 0.5$	$\pm 0.5$	$\pm 0.5$
Max. permissible angular displacement	$\alpha$	[°]	$\pm 0.5$	$\pm 0.5$	$\pm 0.5$	$\pm 0.5$	$\pm 0.5$

**i** Short-term, larger displacements, e.g. when starting and stopping a diesel engine, are permissible. Further information on installation can be found in the operating instructions.

# RCT

## Bellhousingflange PFT

As a supplementary product to its RCT couplings, REICH offers matching bellhousing flanges: By means of the bellhousing flange the pump housing is mounted to the engine flywheel housing. The power is transmitted from the engine flywheel via the RCT coupling to the pump shaft.

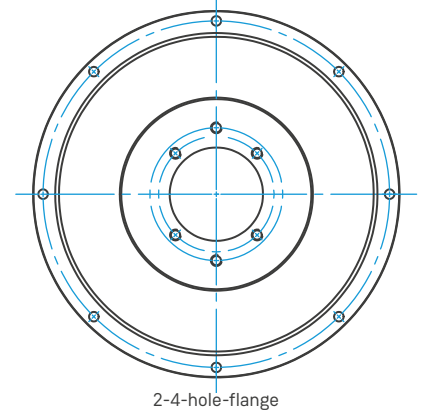
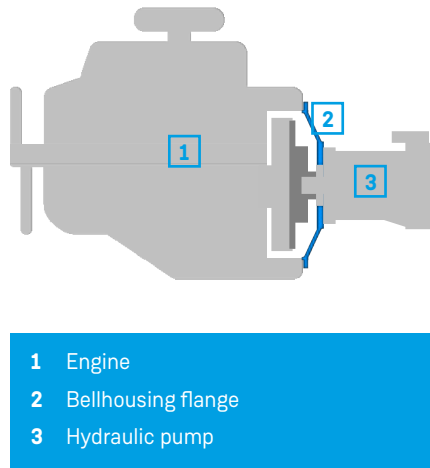
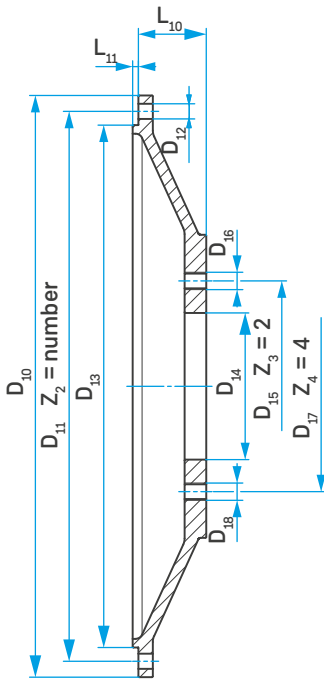

Fig. 1<sup>1)</sup>

### Flange details

Engine housing SAE J 617	Bell flange SAE J 744 2-4-hole	Engine side								Pump side				L <sub>10</sub> [mm]	L <sub>11</sub> [mm]
		D <sub>10</sub> [mm]	D <sub>11</sub> [mm]	Z <sub>2</sub>	D <sub>12</sub> [mm]	D <sub>13</sub> [mm]	D <sub>14</sub> [mm]	D <sub>15</sub> [mm]	Z <sub>3</sub>	D <sub>16</sub> [mm]	D <sub>17</sub> [mm]	Z <sub>4</sub>	D <sub>18</sub> [mm]		
5	A <sup>2)</sup>	356.0	333.4	8	11.0	314.3	82.55	106.4	2	Thread acc. to customer specs	-	-	Thread acc. to customer specs	Length acc. To application	4.0
	101.6						146.0	2	127.0		4				
4	A <sup>2)</sup>	404.0	381.0	12	11.0	362.0	82.55	106.4	2	Thread acc. to customer specs	-	-	Thread acc. to customer specs	Length acc. To application	4.0
	B						101.6	146.0	2		127.0	4			
	C						127.0	181.0	2		161.9	4			
3	B	451.0	428.6	12	11.0	409.6	101.6	146.0	2	Thread acc. to customer specs	127.0	4	Thread acc. to customer specs	Length acc. To application	4.0
	C						127.0	181.0	2		161.9	4			
	D						152.4	228.6	2		228.6	4			
	E						165.1	317.5	2		317.5	4			
2	C	489.0	466.7	12	11.0	447.7	127.0	181.0	2	Thread acc. to customer specs	161.9	4	Thread acc. to customer specs	Length acc. To application	5.0
	D						152.4	228.6	2		228.6	4			
	E						165.1	317.5	2		317.5	4			
1	C	552.0	530.2	12	12.0	511.2	127.0	181.0	2	Thread acc. to customer specs	161.9	4	Thread acc. to customer specs	Length acc. To application	5.0
	D						152.4	228.6	2		228.6	4			
	E						165.1	317.5	2		317.5	4			

1) Bellhousing flange/contour may differ 2) only 2-hole flange

The selection of both the bellhousing flange and the RCT coupling is subject to verification by REICH with regard to the existing mounting situation of the pump drive.

## Data Required for Coupling Size Selection

### Engine side:

1. Engine type: \_\_\_\_\_
2. Engine power: P \_\_\_\_\_ [kW]
3. Engine speed: n \_\_\_\_\_ [min<sup>-1</sup>]
4. In-line/V-engine: R/V \_\_\_\_\_ (angle)
5. Number of cylinders: \_\_\_\_\_
6. Total stroke volume:  $V_H$  \_\_\_\_\_ [ccm]
7. Moments of inertia (engine + flywheel): J \_\_\_\_\_ [kgm<sup>2</sup>]
8. Gas pressure diagram: \_\_\_\_\_
9. Vital information/rules for selecting the coupling size: \_\_\_\_\_
10. Drawing of engine flywheel and engine housing with position markings: \_\_\_\_\_

### Output side:

1. Application (generator, pump, compressor etc.): \_\_\_\_\_
2. Type: \_\_\_\_\_
3. Moments of inertia: J \_\_\_\_\_ [kgm<sup>2</sup>]
4. Shaft diameter: d \_\_\_\_\_ [mm]
5. Shaft length: l \_\_\_\_\_ [mm]
6. Drawing of the prime mover: \_\_\_\_\_

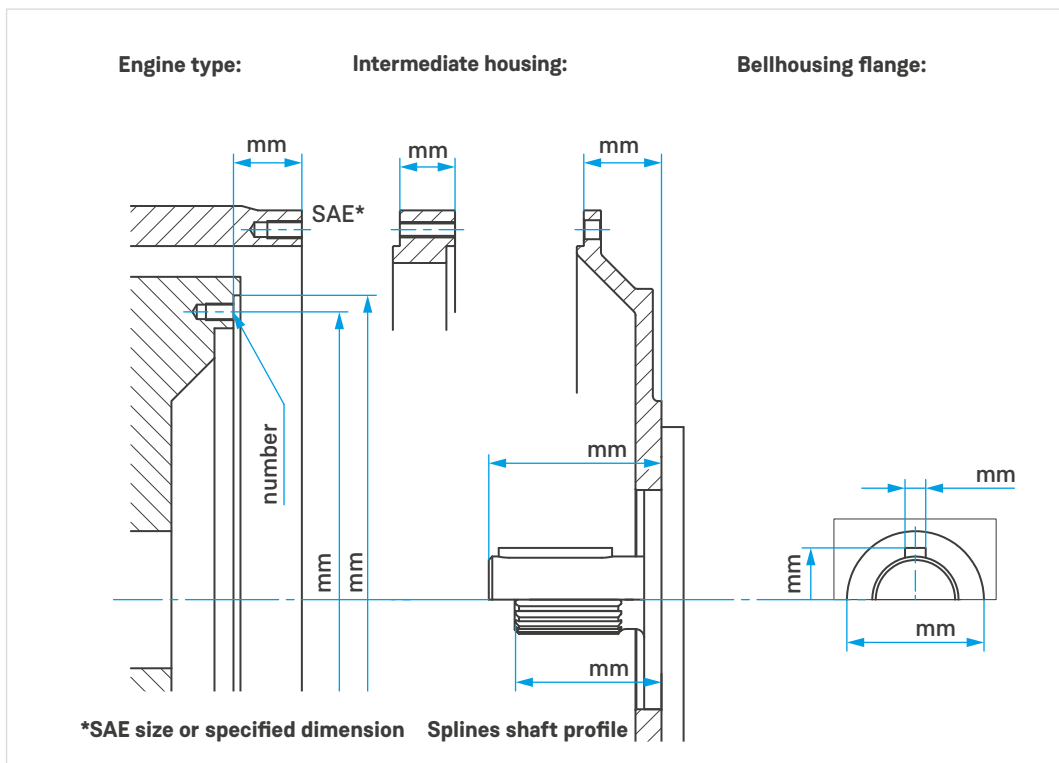











## RCT

SIMPLY **POWERFUL.** 



### Industrial solutions:

-  Power generation
-  Mobile applications
-  Test benches
-  Pumps & compressors
-  Industry
-  Ship & port engineering

### Headquarter:

Dipl.-Ing. Herwarth Reich GmbH  
Vierhausstrasse 53 · 44807 Bochum

 +49 234 959 16-0

 [mail@reich-kupplungen.com](mailto:mail@reich-kupplungen.com)

 [www.reich-kupplungen.com](http://www.reich-kupplungen.com)

### Copyright ISO 16016 to be observed:

The reproduction, distribution and utilisation of this document as well as the communication of its contents to others without explicit authorisation is prohibited. Offenders will be held liable for the payment of damages. All rights reserved in the event of the grant of a patent, utility model or design. © REICH - Dipl.- Ing. Herwarth Reich GmbH

### March 2022 edition

The present RCT catalogue edition renders parts of the previous RCT catalogues obsolete. All dimensions in millimetres. We reserve the right to change dimensions and/or design without prior notice. Texts and illustrations, dimensional and performance data have been compiled with the utmost care. There is no guarantee, however, that the information is accurate; in particular, there is no guarantee that products will match the illustrations in terms of technology, colour, shape and configuration or that the products will correspond to the proportions of the illustrations. We also reserve the right to make changes due to printing errors or mistakes.