

BENZ Nanofix[®]

- + Modular quick-change system
- + Can be used in very small workspaces
- + Simple handling
- + Convincing performance

METAL MACHINING



BENZ NANOFIX®

MODULAR QUICK-CHANGE SYSTEM

QUICK CHANGE IN CONFINED SPACES

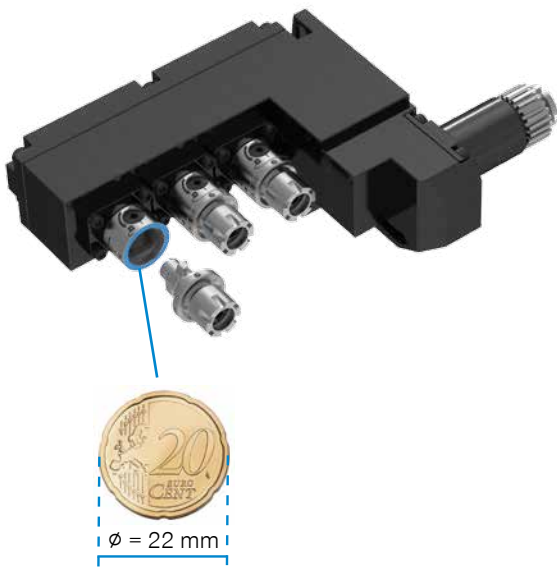
BENZ Nanofix® is a new quick-change interface that is convincing thanks to its extremely compact design. The outer diameter of 22 mm is designed for minimal spindle distances and is therefore particularly suitable for use in confined spaces.



Quick-change system		Outer diameter					
		Ø 22	Ø 32	Ø 40	Ø 50	Ø 63	Ø 75
BENZ Nanofix® new		N2					
BENZ Solidfix®			S1	S2	S3	S4	S5
BENZ CAPTO™			C3	C4	C5	C6	

APPLICATION AREAS



► **Swiss-type turning:** Units with several spindles that are arranged next to each other at small centre distances.



► **Multi-spindle drilling heads** with minimal centre distances



► **Narrow angle heads** with sophisticated workpiece interference contours

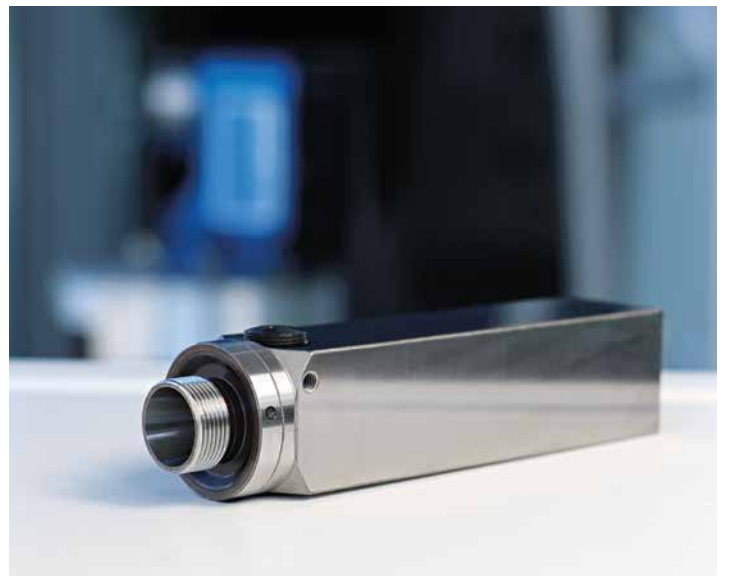

BENZ NANOFIX®

MODULAR QUICK-CHANGE SYSTEM

► SYSTEM DESIGN



MMS-capable



IC-capable

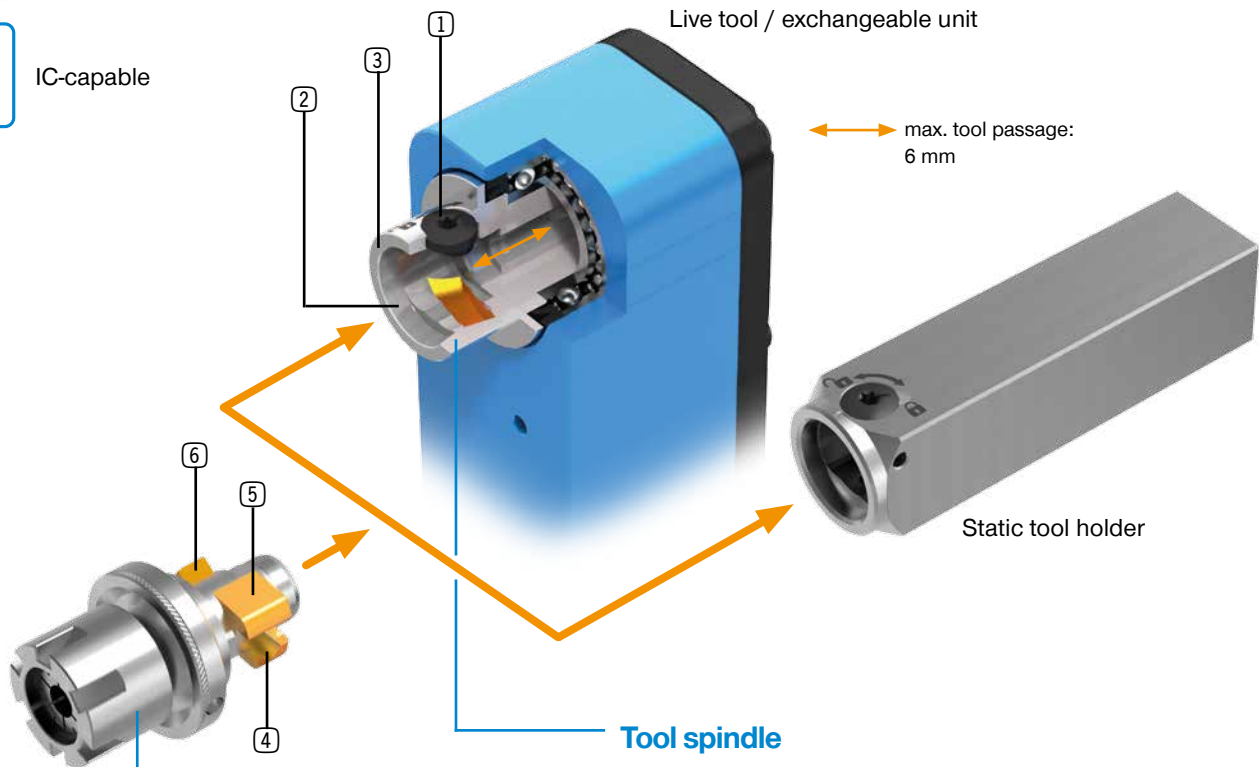

Live tool / exchangeable unit

max. tool passage:
6 mm

Static tool holder

Tool spindle

- ① **Clamping screw**
 - for clamping and loosening the tool adapter
 - activation using standard tool
- ② **Pin centring**
 - high level of concentricity and precision
- ③ **Planar**
 - high level of stability and rigidity

Tool adapter

- ④ **Clamping shoulder**
 - for applying axial force
- ⑤ **Release bar**
 - presses the adapter when releasing from the tool spindle
- ⑥ **Bayonet fitting**
 - prevention of loss when inserting the tool adapter

► BENEFITS



PERFORMANCE

- compact design
- large planar contact surface
- high system rigidity (suitable for milling)
- high torque transmission
- high speeds due to neutrally balanced design

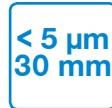

PRECISION

- very high concentricity < 5 μm on 30 mm
- high repeat accuracy
- play-free centering of taper
- short projection



HANDLING

- quick tool change < 20 seconds
- one-hand operation
- integrated ejection function
- adapters can be preset outside of the machine



SAFETY

- securing device via safety bayonet
- self-locking clamping function
- prevention of operating errors
- fulfills machinery directive 2006/42/EG

REDUCE SETUP TIME = SAVE COSTS

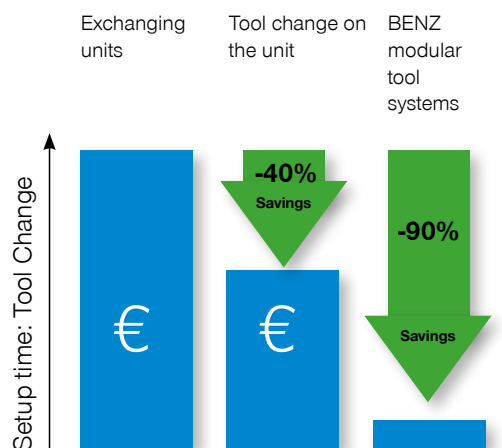

Long machine standstill times arise for a tool change where the complete unit is taken out of the machine. By changing the cutting tool directly on the unit, setup times can already be reduced by 40%. The optimum can be achieved with modular quick-change systems. Here the cutting tool is measured outside of the machine in the presetting device. Replacing the adapter therefore only requires a few seconds. You save 90% of your original setup costs! You also reduce your reject rate as the first part is already a good part.

BENZ NANOFIX® ADAPTER PROGRAM

Adapter for rotating tools



- Blank
- Weldon
- Collet chuck (internal + external)
- Test arbor

EXCHANGEABLE UNITS / LIVE TOOLS

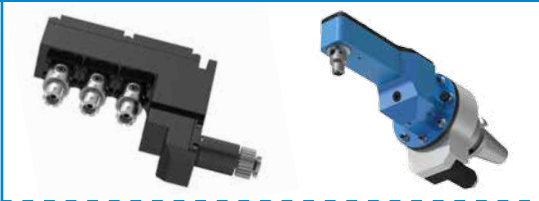

STATIC TOOL HOLDER



Master shank

Adapter for static tools



- Special fixture
- Turning tool

BENZ NANOFIX®

TOOL CHANGE



≤ 00:20



← Observe marking

← Activity

Clamp

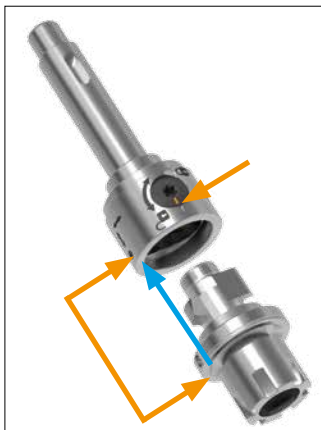

① **Insert the adapter**
- observe markings



② **Turn adapter**
- up to limit stop (by approx. 70°)

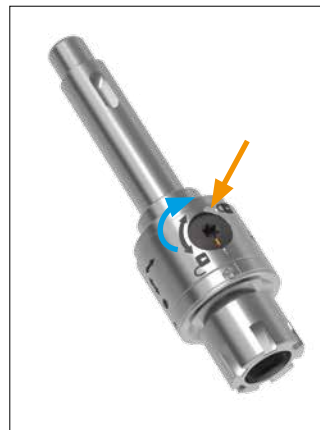

③ **Activate clamping screw**
- with standard tool



④ **Adapter is clamped**

Loosen



① **Adapter is clamped**



② **Activate clamping screw**
- turn left up to the starting position



③ **Turn adapter back**
- up to marking



④ **Remove adapter**



We recommend clamping with a torque wrench for optimum machining results

BENZ GMBH WERKZEUGSYSTEME

BENZ PRECISION TOOLS PROVIDE REFINED SOLUTIONS, INNOVATIVE TECHNOLOGY AND THE HIGHEST LEVELS OF QUALITY IN PRECISION MACHINING.

AS PART OF THE ZIMMER GROUP, WE GO ONE STEP FURTHER. THE NEW **ZIMMER GROUP UMBRELLA BRAND COMBINES THE COMPANIES ZIMMER GMBH, ZIMMER KUNSTSTOFFTECHNIK, ZIMMER DAEMPFUNGSYS-TEME AND BENZ WERKZEUGSYSTEME INTO ONE PARTNER FOR YOUR PROJECTS: THE KNOW-HOW FACTORY.**

CHALLENGE US. DISCOVER THE ENTIRE WORLD OF ZIMMER GROUP! IF YOU HAVE QUESTIONS ABOUT THE NEW ZIMMER GROUP AND OUR TECHNOLOGY, WE WOULD BE HAPPY TO ANSWER THEM.

CONTACT

BENZ GmbH Werkzeugsysteme

Im Mühlegrün 12

D-77716 Haslach

T +49 7832 704-0

F +49 7832 704-8001

info@benz-tools.de

www.benz-tools.de

