

Screw
conveyors

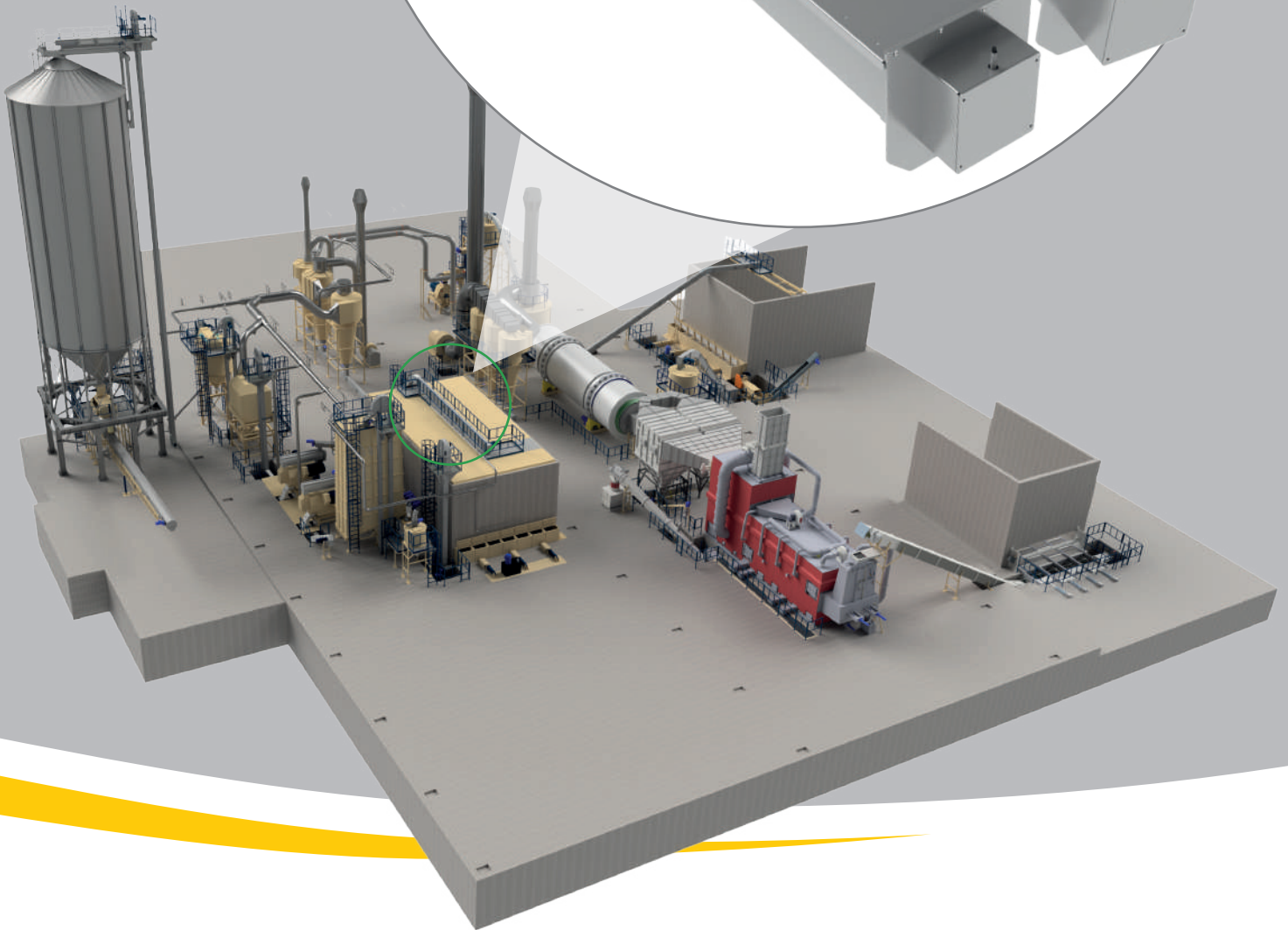

COMERC
ACCORDING TO NATURE

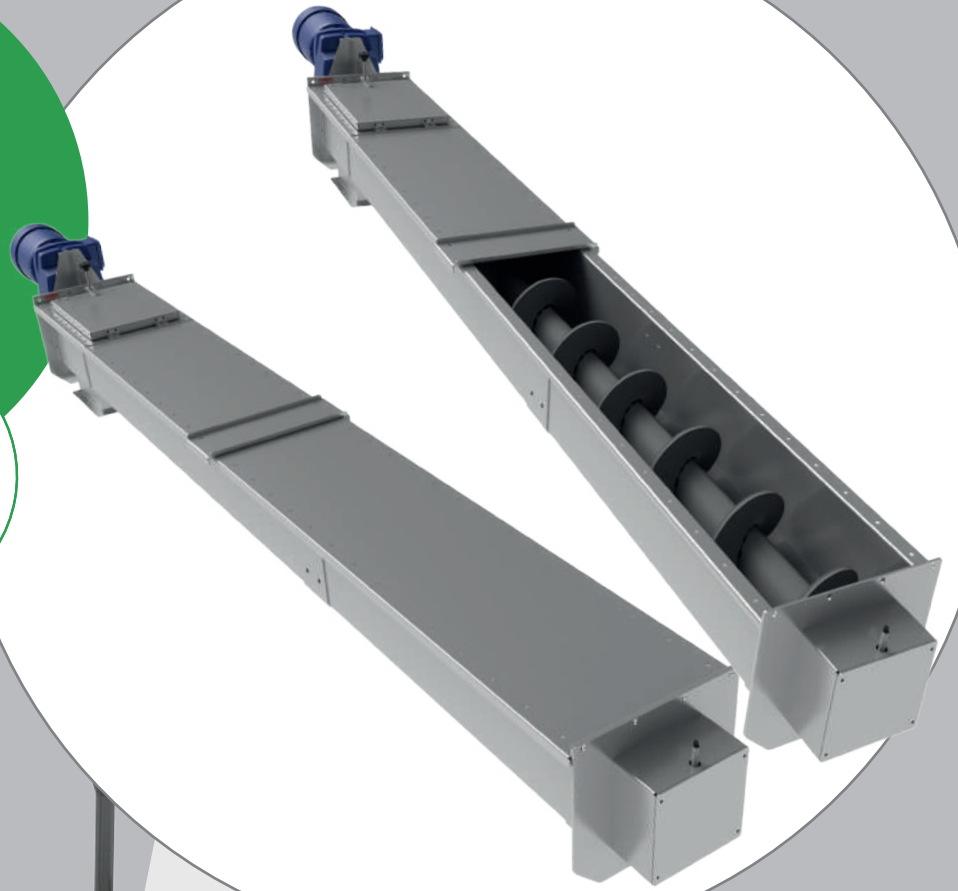

COMERC

ACCORDING TO NATURE

Screw conveyors

Screw conveyors are used for transporting sawdust, wood chips, pellets and other bulk materials. Conveyor housing is made of structural steel with Magnelis® coating. Worm is made of thick-walled steel pipe with 10 mm thick spiral welded to the pipe. End necks welded on both ends of the worm are designed to be mounted in high-quality self-aligning ball bearings (SKF or INA/FAG) with UCF housing. Additionally, our screw conveyors are equipped with rotation monitoring sensors and inspection hatches with overflow sensors.

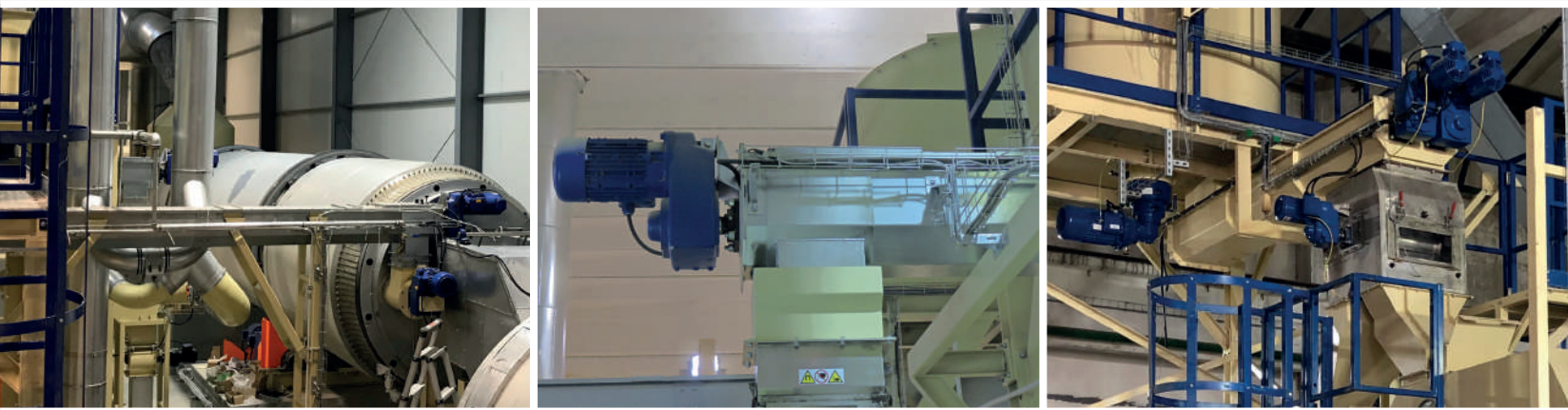

Basic parameters of screw conveyors	
Model/Type	CPS 250, 300, 350, 400, 450, 500
Material	structural steel
Overlay	Magnelis®
Drive type	helical gear motor Nord
Drive	electric motor 400 V
Bearing / housing	SKF, SNR
Capacity	15 - 100 m ³ /h
Lenght	0,5 – 8,5 m
Manufacturer	Comerc®

Magnelis® is a new metallic coating, which assures long-lasting corrosion and surface protection (10 times higher resistance than the galvanized steel).

ul. Podbiałowa 9, 61-680 Poznań,
tel. +48 61 875 07 15, e-mail: office@comerc.pl,
www.comerc.pl/offer/1

