

Metal Bellows Coupling I Series KG

- /// all-metal version up to 300°C /// wear and maintenance free
- /// very short and variable design /// torsionally stiff
- /// simple installation with EASY-clamping hub

technical data:

KG size	T _N [Nm]	moment of inertia [10 ⁻³ kgm ²]	torsional stiffness [Nm/arcmin]			max. shaft misalignment [mm]						axial spring rate [N/mm]			lateral spring rate [N/mm]			nmax. [upm]
			2W	4W	6W	axial±			lateral			2W	4W	6W	2W	4W	6W	
						2W	4W	6W	2W	4W	6W							
40	40	0,18	16	9	6	0,3	0,6	0,8	0,1	0,2	0,3	130	70	50	2500	490	190	23000
80	80	0,44	26	14	9	0,3	0,6	0,8	0,1	0,2	0,3	120	70	50	3500	600	260	20000
140	140	0,74	32	20	13	0,3	0,6	1	0,1	0,2	0,3	210	110	80	7000	1200	400	18000
220	220	1,2	50	28	17	0,4	0,7	1	0,1	0,2	0,3	170	95	70	5000	1000	470	16000
400	400	2,6	93	74	47	0,4	0,7	1	0,1	0,2	0,3	170	130	95	7000	1500	500	13000
700	700	5,4	190	106	68	0,4	0,8	1	0,1	0,2	0,3	260	140	100	15000	2800	980	11000
900	900	11	280	156	105	0,4	0,8	1	0,1	0,2	0,3	380	210	140	18000	3050	1000	10000
1300	1300	24	400	225	170	0,4	0,7	1	0,1	0,2	0,3	310	160	120	13000	2100	920	8500
2000	2000	40	400	340	260	0,4	1	1	0,1	0,2	0,3	310	340	250	13000	4800	1600	8500
3000	3000	75	-	700	490	-	1,5	2	-	0,2	0,4	-	290	200	-	4900	1600	6500

Sizes for smaller nominal torques see miniature couplings series MKG
temperature range: -40°C up to +300°C

material:

bellows: stainless steel 1.4571

hubs: steel St 52 - burnished

screws:

ISO 4762 / 12.9

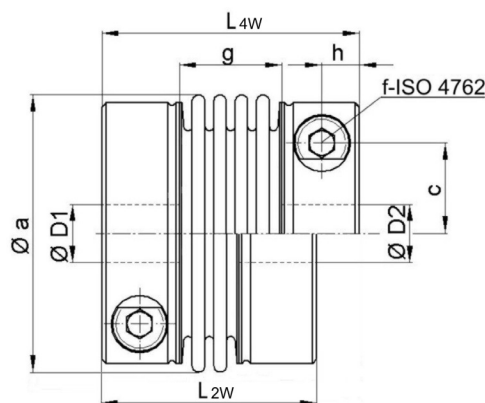

note: connection between bellows and hub by plasma welding

Three standard versions with 2-corrugated metal bellows 2W, 4-corrugated metal bellows 4W or 6-corrugated metal bellows 6W. • Note for size KG 2000/3000: Technical data for bellows version 4W / 6W instead of 2W / 4W

Dimensions [mm]: length dimensions according to DIN ISO 2768 cH

KG	Ø a	c	f-TA	g			h	L			mass ~[kg]	Ø D1/2	
				2W	4W	6W		2W	4W	6W		min	max
40	56	18	M6-16 Nm	13	23	34	7,5	45	55	66	0,5	12	32
80	66	22,5	M8-40 Nm	16	24	35	9	53	61	72	0,9	14	35
140	71	27	M8-40 Nm	15	25	36	9	52	62	73	1,1	18	42
220	82	27,5	M10-65 Nm	18	28	41	11,5	63	73	86	1,5	20	42
400	101	32	M12-135 Nm	19	30	49	12,5	71	82	101	2,4	22	50
700	122	40	M12-115 Nm	22	37	52	11,5	70	85	100	3,4	42	64
900	132	45	M14-200 Nm	22	38	54	15,5	86	102	118	5,5	42	70
1300	157	54	M16-290 Nm	24	40	56	17,5	95	111	127	8,5	50	90
2000	157	58	M20-450 Nm	24	40	56	22	113	130	146	12	60	90
3000	203	61	2xM16-300 Nm	-	43	61	18/32	-	187	205	19	60	100

• alternative lengths and hub versions are possible on request

order example: KG 40 / 4W D1 = 16^{G7} D2 = 24^{H7}
 KG 400 / 2W D1 = 32^{G7} D2 = 35^{G7}
 KG 2000 / 6W D1 = 65^{G7} D2 = 75^{G7}