

## • Technical data

Type		LG M40 T2 275 RM/3+N	
Art.-No.		810 813	
Rated voltage (max. continuous voltage)	$U_c$	275V~ (L-N)	255V~ (N-PE)
Nominal discharge current (8/20)	$I_n$	20kA (L-N)	40kA (N-PE)
Max. discharge current (8/20)	$I_{max}$	40kA (L-N)	65kA (N-PE)
Lightning impulse current (10/350)	$I_{imp}$	20kA (N-PE)	
Voltage protection level at $I_n$	$U_p$	$\leq 1.25kV$ (L-N)	$\leq 1.5kV$ (N-PE)
Voltage protection level 5kA	$U_p$	$\leq 1.0kV$ (L-N)	
Response time	$t_A$	$\leq 25ns$ (L-N)	$\leq 100ns$ (N-PE)
Follow current extinguishing capability at $U_c$	$I_f$	100A <sub>rms</sub> (N-PE)	
Max. back up fuse		125A gL/gG (L-N)	
Operating temperature range	$T_u$	-40°C...+80°C	
Cross-sectional area		1.5mm <sup>2</sup> ~ 25mm <sup>2</sup> solid / 35mm <sup>2</sup> flexible	
Mounting on		35mm DIN rail	
Enclosure material		Light grey thermoplastic, UL94-V0	
Dimension		4 mods	
Test standards		IEC 61643-11; GB 18802.11	
Certification		CE (LVD, EMC)	
Type of remote signalling contact		Switching contact	
Switching capacity	$U_N/I_N$	AC:250V/0.5A DC:250V/0.1A, 125V/0.2A, 75V/0.5A	
Cross-sectional area for remote signalling contact		Max. 1.5mm <sup>2</sup> solid / flexible	

## • Product introduction

### 1. Summary

LG M40 T2 275 RM/3+N is for installation at LPZ 0<sub>B</sub>-1 or higher, protecting low voltage equipment from surge. Applied in pluggable SPD Class II (Class C) for TT and TN-S power supply system. Designed according to IEC 61643-11/GB 18802.11.

### 3. Application

LG M40 T2 275 RM/3+N is applied in three-phase TT and TN-S system ("3+1" circuit).

## • Installation instruction

According to lightning protection zones concept, for installation at LPZ 0<sub>B</sub>-1 or higher. This surge protective device is usually installed in distribution-box or feeder bus of UPS, protecting devices or equipment downstream.

Fuse must be installed at the upstream of the SPD or the lightning arrester to make sure that the protected system has double protection. The value of the fuse used in a SPD system should be conformed to:

1. The value of FUSE should not be larger than the max. withstand capacity of the SPD's backup fuse value.
2. Under the status of the max. current in the power supply & close loop circuit available current, the fuse should be able to disconnect when overloaded or short-circuited.
3. Take 1 & 2 into consideration, the fuse should be as large as possible to allow the maximum surge discharge of SPD.

## 2. Main character

- Pluggable module, easy for installation and maintenance
- High discharge capacity, quick response
- Double thermal disconnecter devices, providing more reliable protection
- Green window will change when fault and also provide remote alarm control at the same time

## 4. Application environment

- Temperature: -40°C ~ +80°C
- Relative humidity:  $\leq 95\%$  (25°C)

## • Installation steps

1. Check the product for integrity of the package; make sure the product window not indicates red.
2. Mount the SPD on the 35mm DIN rail.
3. Connect conductors, the cross-sectional area of cable must be larger than 6mm<sup>2</sup>. The withstand voltage value of cable is not smaller than AC500V; ensure wiring reliable.
4. If need remote alarm, it should be connected signal lines to remote signal terminal 1 and 2, or 2 and 3 (normal, 1 and 2 open, 2 and 3 close; when fault, the state is reversed).
5. After above, switch on the power supply and turn on the circuit breaker, if the SPD's window does not appear red, this indicates the unit is operating normally.

**Regularly inspect the operating status, especially after lightning. Once the fuse upstream breaks, or the SPD's window indicates red, electrician should check/replace the SPD.**

### LG M40 T2 275 RM/3+N installation diagram:

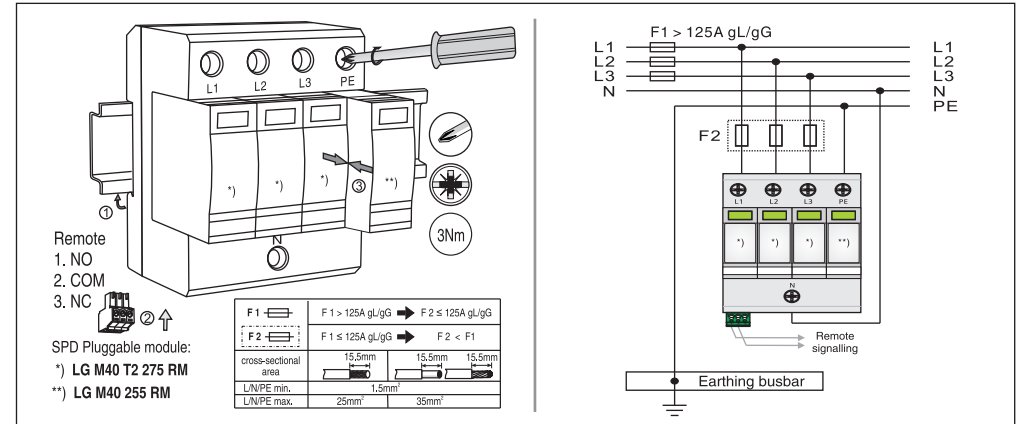

**WARNING:**

1. The device must be installed by electrically skilled person, conforming to national standards and safety regulations.
2. It is recommended that installation should be done under power off condition.