

Metal Bellows Coupling I Series KGH

- /// simple installation - split-hub design
- /// backlash free - torsionally stiff // wear and maintenance free
- /// variable length // all-steel-version // up to 350°C

technical data:

KGH size	T _N [Nm]	moment of inertia [10 ⁻³ kgm ²]	torsional stiffness [Nm/arcmin]			max. shaft misalignment [mm]						axial spring rate [N/mm]			lateral spring rate [N/mm]			n _{max} [upm]
			2W	4W	6W	axial±			lateral			2W	4W	6W	2W	4W	6W	
			2W	4W	6W	2W	4W	6W	2W	4W	6W	2W	4W	6W	2W	4W	6W	
20	20	0,045	6	3,4	2,4	0,3	0,4	0,5	0,1	0,15	0,25	100	55	50	2100	360	110	23000
40	40	0,2	9	16	6	0,3	0,6	0,8	0,1	0,2	0,25	130	70	50	2500	450	190	17000
80	80	0,5	26	14	9	0,3	0,6	0,8	0,1	0,2	0,3	120	70	50	3500	600	260	14000
140	140	0,8	32	20	13	0,3	0,6	1	0,1	0,2	0,3	110	210	80	7000	1200	400	13000
220	220	1,4	50	28	17	0,4	0,7	1	0,1	0,2	0,3	170	95	70	5000	1000	470	11000
350	350	3,0	93	52	47	0,4	0,8	1	0,1	0,2	0,3	170	90	95	7000	1300	500	9500
700	700	7,3	190	106	68	0,4	0,8	1	0,1	0,2	0,3	260	140	100	15000	2800	980	8000
1800	1800	46	-	300	260	-	1	1	-	0,2	0,3	-	340	250	-	4700	1600	6000

maximum temperature range: -40°C up to +350°C

material: hubs: steel St 52
bellows: stainless steel 1.4571 screws: ISO 4762 / 12.9

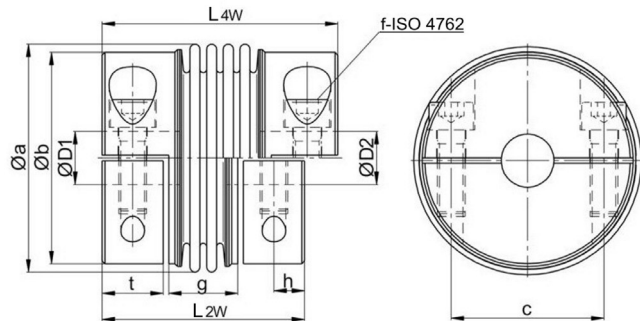

note: Standard versions with 6-corrugated metal bellows 6W, 4-corrugated metal bellows 4W or with 2-corrugated metal bellows 2W -> see values in brackets. Connection of bellows and hubs by micro-plasma welding process.

Dimensions [mm]: length dimensions according to DIN ISO 2768 cH

KGH	Ø a	Ø b	c	f-TA	g			h	L			t	mass ~[kg]	Ø D1/2	
					2W	4W	6W		2W	4W	6W			min	max
20	40	38	25,5	M5 - 10 Nm	17	22	28	6	45	50	56	12	0,25	8	19
40	56	51	36	M6 - 16 Nm	22	32	42	7,5	56	66	76	15	0,6	12	28
80	66	62	45	M8 - 40 Nm	24	32	43	8	60	68	79	16	0,9	14	35
140	71	71	54	M8 - 40 Nm	23	33	44	8,5	61	71	82	17	1,25	14	42
220	82	76	55	M10 - 80 Nm	27	37	49	11	75	85	97	22	1,8	20	42
350	101	89	64	M12 - 135 Nm	29	40	59	13	83	94	113	24	2,8	22	48
700	122	108	78	M14 - 200 Nm	31	47	62	15	91	107	122	27	4,5	35	62
1800	157	145	108	2x M16 - 300 Nm	-	55	70	18/30	-	190	206	64	15	35	85

Mounting Instructions:

The split-hub design allows for a easy assembly. Further simplification during installation is provided because one half of the split hub is put onto the shaft. This allows that the coupling can rest on the two shaft ends. The second half of the split hub can then be mounted to the coupling by screwing it on from below with the specified tightening torque. This feature makes "one man assembly" possible.

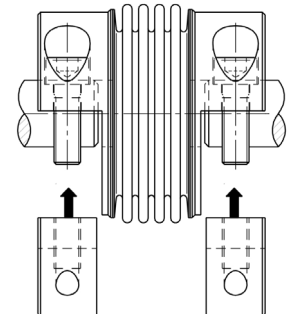

order example: KGH 220 / 4W - D1 = 24^{G7} D2 = 30^{G7}