



UNDERSURFACE UNIT - CLASSIC LINE SUBIO

TECHNICAL DATA

Lubrication Grease
 Max. drive speed n_2 10,000rpm
 Transmission ratio ($n_1: n_2$) 1:1
 Max. drive torque M_2 8Nm
 Weight about 7 kg

STANDARD DESIGN

- 1  Machine Connection
HSK - F63
- 2  Head size
M
- 3  Output spindle
Collet chuck
ER25A

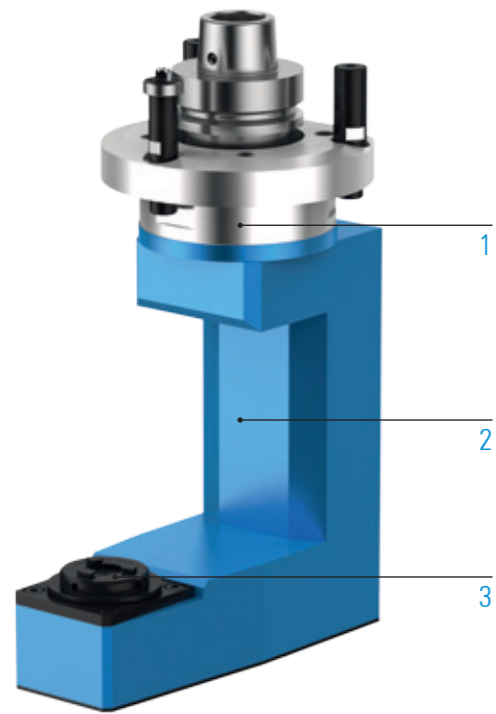

ADDITIONAL OPTIONS: MODULAR DESIGN

1



MACHINE CONNECTION



i For further information see p. 106

2



HEAD SIZE



i Additional projections and lengths on request

3



OUTPUT SPINDLE



i For further information see p. 108

MACHINING



Drilling



Milling

SPECIFICATIONS

 Number of output spindles

 Axis angle

 C-angle

 Grease lubrication

ORDER DIRECTLY



Inquiry form:
www.benz-tools.de/en/products