

BELT SANDING UNIT - CLASSIC LINE

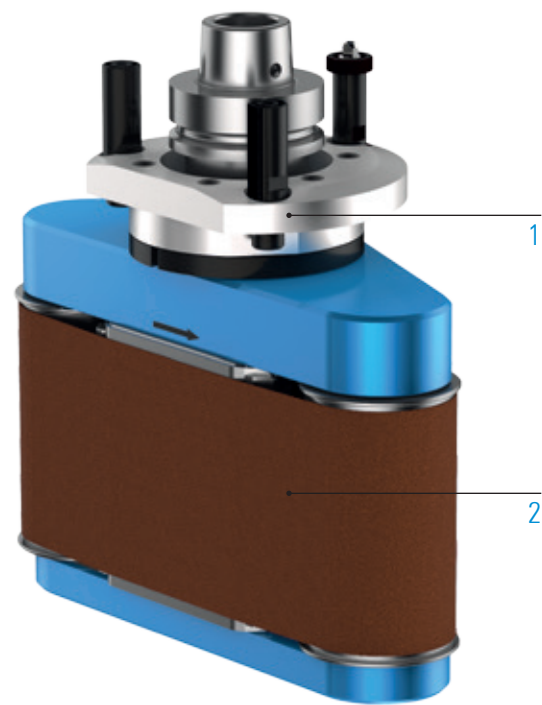

COLLEVO

TECHNICAL DATA

Lubrication	Grease
Max. drive speed n_2	2,700rpm
Transmission ratio ($n_1: n_2$)	1:0.9
Weight	about 9 kg



STANDARD DESIGN

- 
 Machine Connection
HSK - F63
- 
 Sanding belt
 Width 100 mm, length 560 mm

ADDITIONAL OPTIONS: MODULAR DESIGN

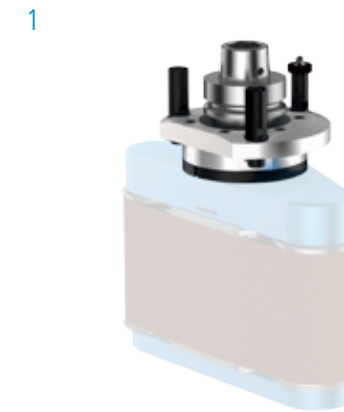

MACHINE CONNECTION



 For further information see p. 106







SANDING BELT



MACHINING



SPECIFICATIONS

-  Number of output spindles
-  Axis angle
-  C-angle
-  Grease lubrication

VIDEO



Unit - live in the application
Scan QR code or go to:
www.youtube.com/BENZWerkzeugsysteme

ORDER DIRECTLY



Inquiry form:
www.benz-tools.de/en/products