

AI2

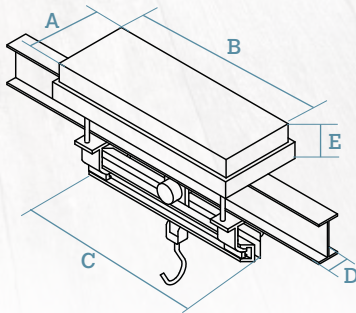

Dimensions DATA IN mm



A	B	C (min.)	C (max.)	D (max.)	E
240	600	560	600	120	110



AERIAL



2
LOAD
CELLS



METROLOGICAL
VERIFICATION
OPTIONAL (EU)

Specifications

Main characteristics

- Weighing scales for overhead track lines.
- 2 load cells.
- Valid for legal metrology (see section on equipment metrological verification).

Construction

- 2 versions:
 - › A- Stainless steel coated galvanised steel structure with aluminium load cells (IP67).
 - › B- Stainless steel coated galvanised steel structure with stainless steel load cells (IP67).

Possible integration with other equipment

- Dibal weight indicators.
- Cely weight indicators.
- Dibal LP-545 manual weigh-price labeller.

Models

RANGE 300 kg (3,000 divisions)

VERSION A:
Aluminium load cells.

Ref.: **711A2H0004**__

VERSION B:
Stainless steel load cells.

Ref.: **711A2I0004**__

RANGE 600 kg (3,000 divisions)

VERSION A:
Aluminium load cells.

Ref.: **711A2H0005**__

VERSION B:
Stainless steel load cells.

Ref.: **711A2I0005**__