

HINGE MORTISING UNIT - CLASSIC LINE

CAVO H

TECHNICAL DATA

Lubrication	Grease
Max. drive speed n_2	4,000rpm
Transmission ratio ($n_1: n_2$)	1:1
Weight	about 4.5kg

STANDARD DESIGN

- 1  Machine Connection
HSK - F63
- 2  Output spindle
Groove width 24

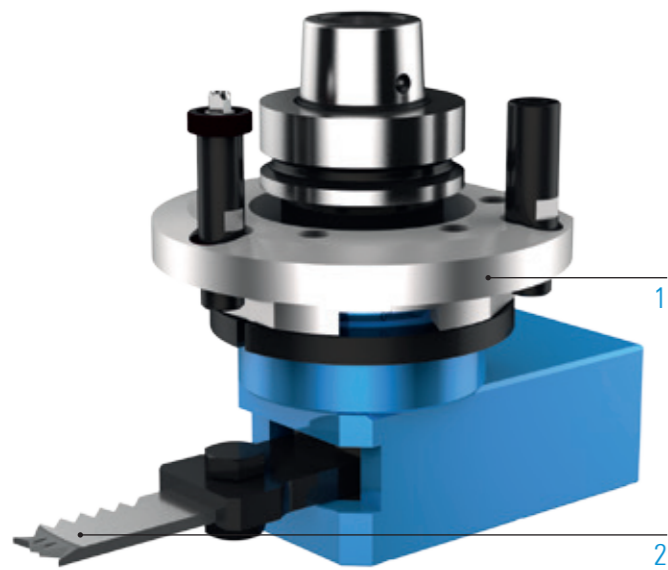

ADDITIONAL OPTIONS: MODULAR DESIGN



MACHINE CONNECTION



 For further information see p. 106

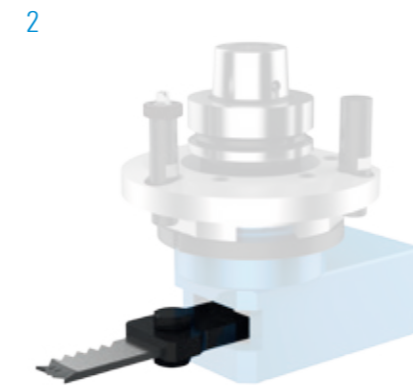

OUTPUT SPINDLE







Groove width 24

MACHINING



SPECIFICATIONS

-  Number of output spindles
-  Axis angle
-  C-angle
-  Grease lubrication

VIDEO



Unit - live in the application
Scan QR code or go to:
www.youtube.com/BENZWerkzeugsysteme

ORDER DIRECTLY



Inquiry form:
www.benz-tools.de/en/products