

## Application Areas

The safety system is integrated into the machine tool by the machine tool producer. It is designed for vertical and horizontal machining centers, which are typically used in tool and mold making or in applications with high varieties in working piece dimensions (toll manufacturers).

## Motor Spindle Safety System MS<sup>3</sup>

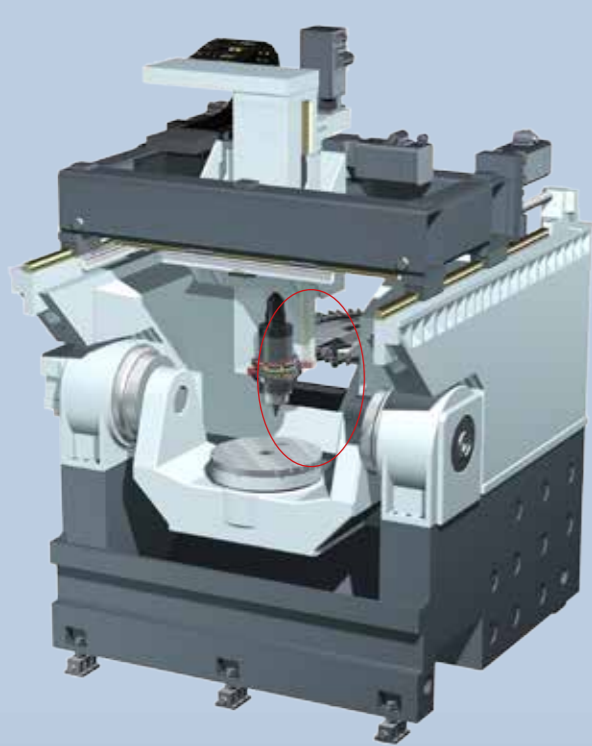

vertical machining center



horizontal machining center

Various different solutions already exist for spindles with HSK-63 and SK-40 interfaces, including the stand-alone version for optional fitting or the compact spindle-integrated version as retro-fit solution. Numerous tests during development have proven that perfect stiffness and precision of the machine tool remain intact after installation.

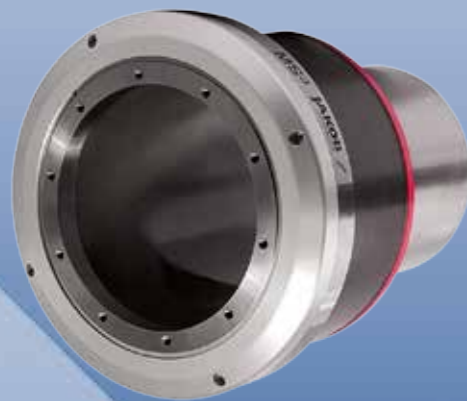

stand-alone version



MS<sup>3</sup> integrated in spindle housing

## Further Advantages

- adaptable to all common motor spindle geometries
- hybrid protection through provision of alarm signal and decoupling paths
- increase of machine availability through prevention of overload damages
- maintenance-free

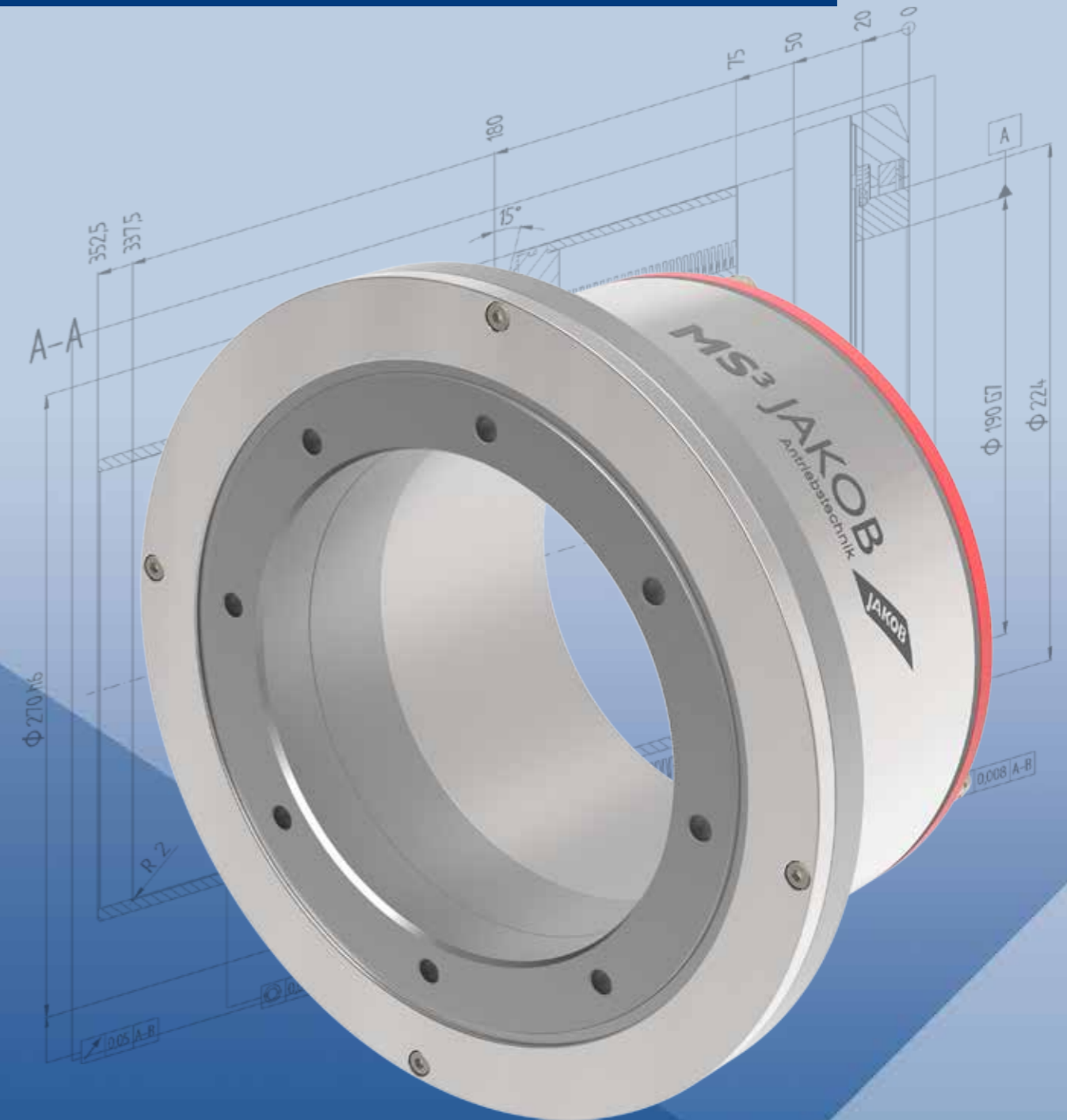

## Collision Protection

Collisions with high feed rates in the working space of cutting machine tools can lead to substantial damages. Studies show, that about 70% of all machine down times are caused by crashes. These often result in damages to sensitive components such as bearings, guides and measuring systems. The costs of repairs and the loss of production average around 25,000€ according to evaluations.

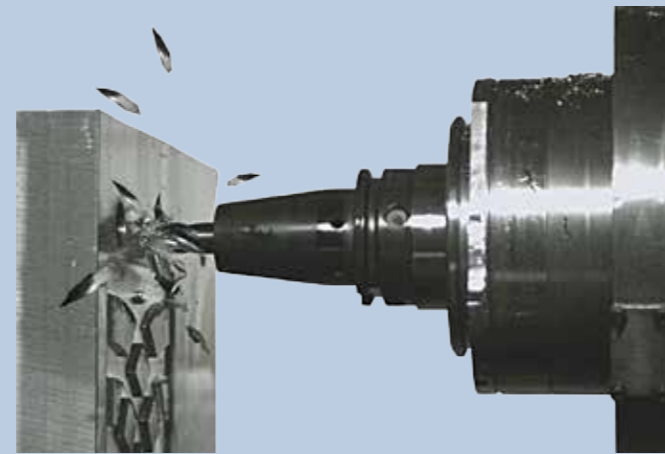

machine tool collision

To protect the machine from costly damages in case of overload and collision, a protective system that prevents unallowable load in machine tools' flux is required.

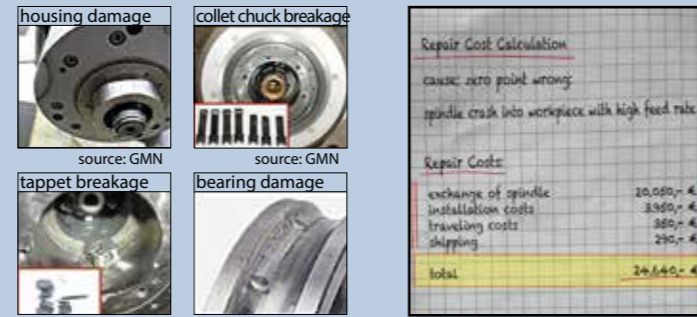

collision costs and damages

## Motor Spindle Safety System MS<sup>3</sup>

The motor spindle safety system MS<sup>3</sup> safeguards the heart of the machine tool, the motor spindle, from collision-induced overload at the tool.

Whenever the allowable force is exceeded, MS<sup>3</sup> disconnects the flux at the connection of machine tool and motor spindle. Depending on the collision direction, the system decouples through axial stroke or a pivoting motion of the spindle. The effective impact force is absorbed effectively. Built-in sensors detect the decoupling and allow for counter measures by the machine control, such as emergency stop or reversing of the feed motion.



axial collision

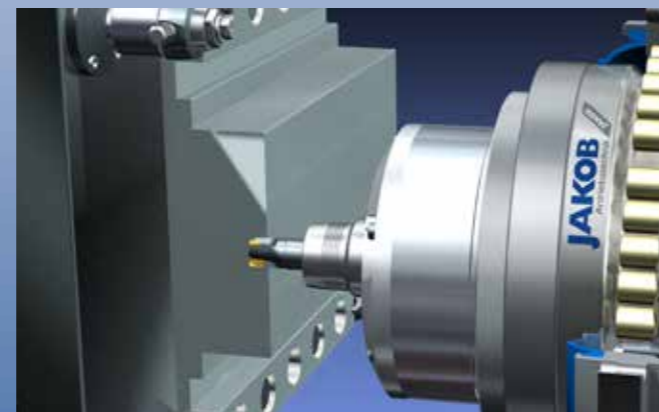

radial collision

The reaction and braking distance of the feed axis is well within the axial stroke and pivot path of the safety system. After retreating from the point of impact, the spindle returns precisely to its initial position thanks to the resetting mechanism. MS<sup>3</sup> can therefore be considered a hybrid protection system and has huge advantages in comparison to electronic monitoring systems.

## Protective Function

The safety system provides all-around protection and prevents damages in case of axial as well as radial collisions with high feed rates.

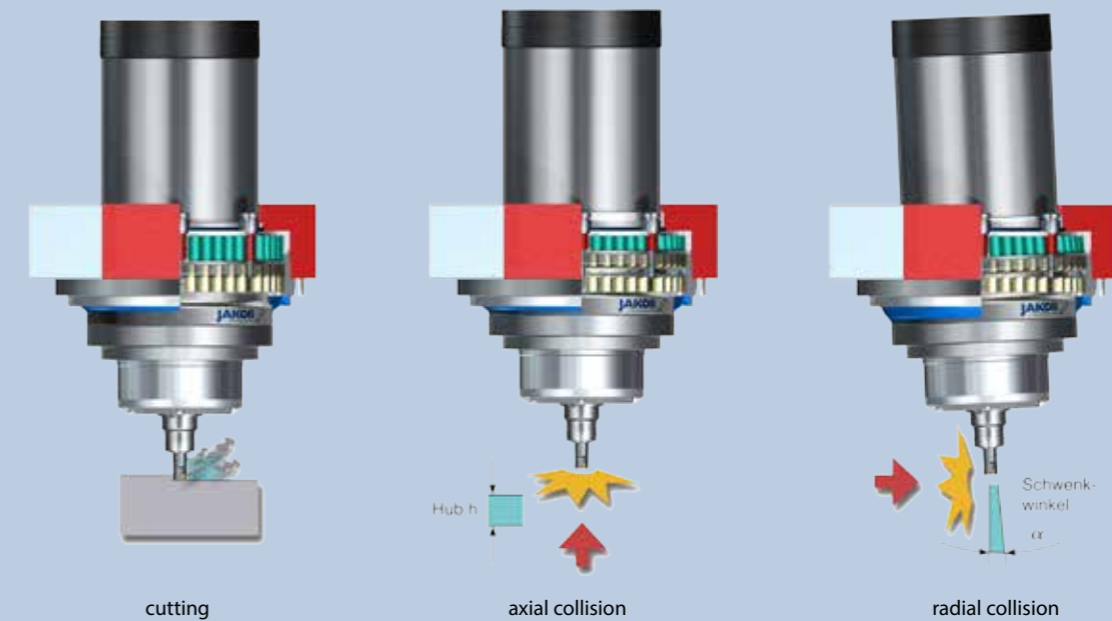

- cutting: spindle remains in initial position
- axial collision: spindle moves from initial position with stroke  $h$
- radial collision: spindle pivots by  $\alpha$  from initial position

## System Design

MS<sup>3</sup> consists of two flange halves, one mounted to the motor and one mounted to the spindle. Permanent magnets supply high adhesive forces and static stiffness until the decoupling force is reached. The tapered division area as well as the indexing of the interface guarantee a high joining precision. A resetting mechanism accomplished by preloaded spring force absorbs forces during a crash and returns the spindle back into its initial position. Sophisticated sealing prevents dirt, coolant, and chips from permeating the housing. Three digital sensors constantly monitor the spindle state and generate a condition signal for machine control.

