

Version A

Version B

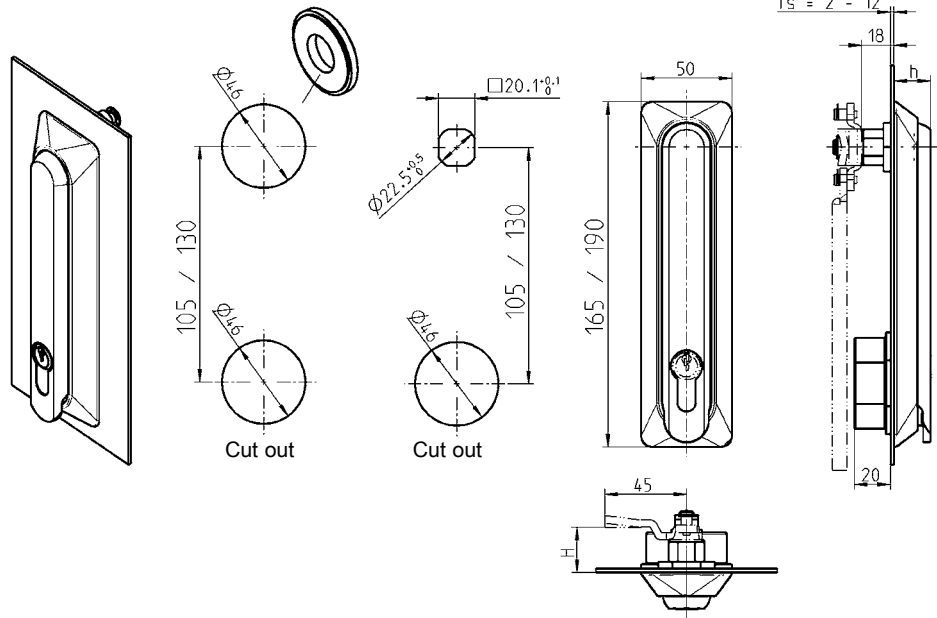

Attention:

With adapter the maximum door gauge (TS) will be 6 mm

Note:

If door gauge (Ts) > 4 mm standard round rods cannot be used!

Swing handle "long" or "short" handle polyamide GF black; dish polyamide GF VO black; shaft brass; cylinder cover polyamide GF black; Fixing material m.s. zinc plated; with seal

Swing handle "long" (190) without cylinder cover

for 40 mm profile half cylinder (h = 20 mm)	1107-U1-G
---	-----------

Swing handle "long" (190) with cylinder cover sealable

for 40 mm profile half cylinder (h = 20 mm)	1107-U2-G
---	-----------

for 40 mm profile half cylinder (h=20 mm) (handle zinc die black powder coated)	1107-U102-G
---	-------------

for 45 mm profile half cylinder (h=25 mm)	1107-U32-G
---	------------

Swing handle "short" (165) without cylinder cover

for 40 mm profile half cylinder (h=20 mm)	1107-U158-G
---	-------------

Swing handle "short" (165) with cylinder cover sealable

for 40 mm profile half cylinder (h=20 mm)	1107-U159-G
---	-------------

for 45 mm Profile half cylinder (h=25 mm)	1107-U169-G
---	-------------

Adapter polyamide GF black required for cut out version A

	1107-53
--	---------

* Order screw set separately if Ts = 4-12 mm	1107-U170
--	-----------

Further parts see page

- Cam 3YC-120
- Rod control for cam 3YC-180
- Profile half cylinder 3XB-120