

Back'light

In the same dynamic as the Domino Sign Rigid'bar, the Domino Sign Back'light is dedicated to the lighting of single-sided boxes, even of very shallow depth, with diffusing or opaque edges.

The very flat diffusion lens coupled with a powerful luminous flux makes it possible to offer a homogeneous qualitative rendering over a very large width: gives a small quantity of modules for a large illuminated surface!



- ☒ Thin and flat module
- ☒ Applications from 8 to 15 cm deep
- ☒ Very good heat dissipation
- ☒ Angle: 175°.
- ☒ 5-year warranty



Back'light	 blanc / white 6500 K
Flux lumineux / Luminous flux (lm)	390 lm / 3 led
Consommation / Consumption (W/module)	1,6
Animateur / Animation	oui / yes
Gradateur / Dimmer	oui / yes

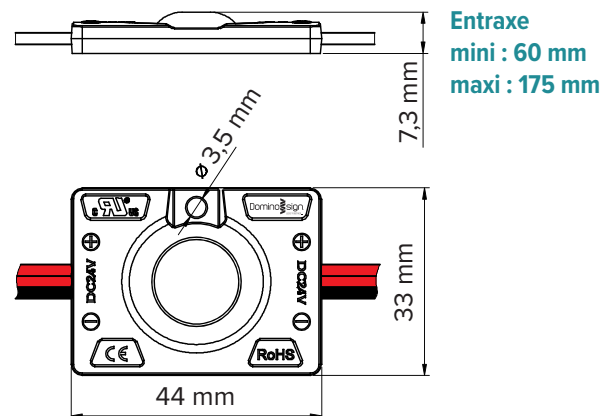

Packaging - Warranty

Packaging: 12 modules per chain

Sales unit: 2 chains per plate (24 modules) or 30 plates per carton (720 modules)

Service life: 50,000 hours

Warranty: 5 years for use from 8 to 10 hours a day



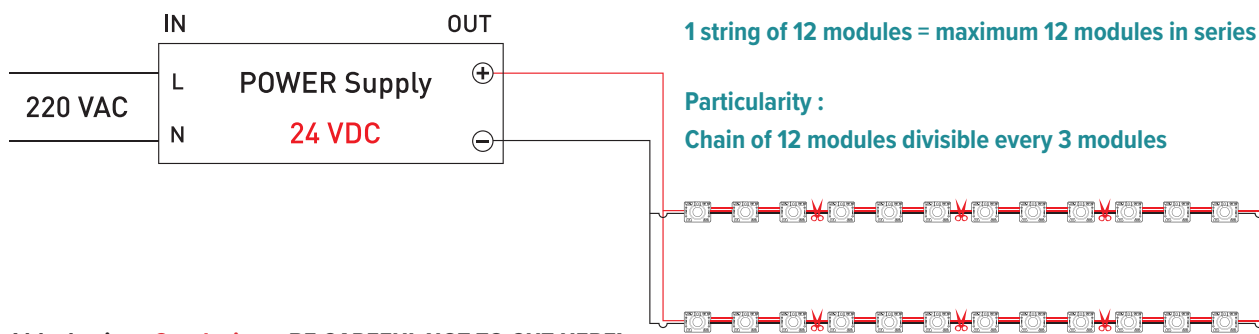
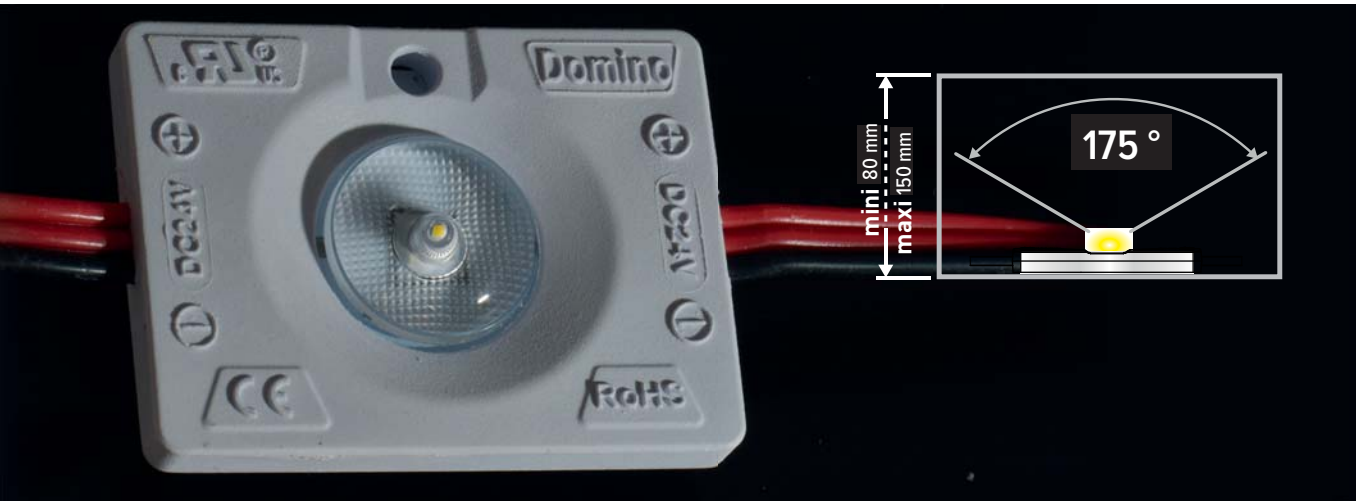

1 black wire + 2 red wires = BE CAREFUL NOT TO CUT HERE!
 Follow-up again of :
 1 black wire (Negative) + 1 red wire (Positive) = CUT HERE

2 Fils = rouge POSITIF et noir NÉGATIF / 24V DC
 2 Wires = red POSITIV & Black NEGATIV / 24V DC

