

CTS SERIES

COGGING TEST SYSTEM

FEATURES

- Measures Detent Torque, Cogging Torque and Friction Torque
- Torque Detection from $< 1 \text{ mN}\cdot\text{m}$ to $1 \text{ N}\cdot\text{m}$
- Rated torque range 50/100/200/500/1000 mN·m
- Accuracy 0.1 % of rated torque
- Angle Detection 0.018° (5000 Pulse Per Revolution)
- Operating speed 1 to (8)10rpm
- Operating Direction CW / CCW
- USB Interface
- Executable Specific Cogging Test Software
- Peak Detection
- X-Y, Polar and FFT Graphs
- Multi-graph capability compares up to 5 curves
- Data Acquisition and Storage in TXT (Export in CSV files possible)

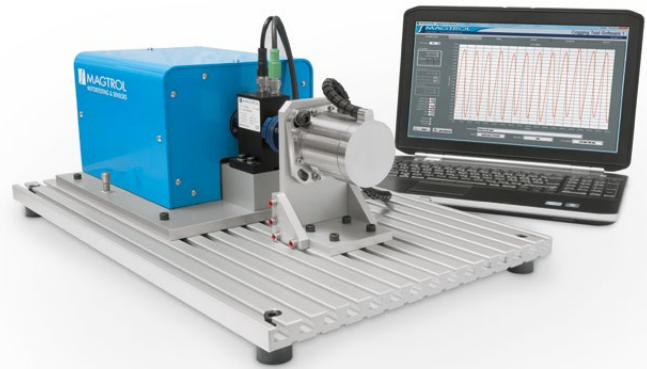

Fig. 1: Cogging Test System with optional FMF Fixed Motor Fixture and dedicated Cogging Test Software (computer not included, available as an option).

OPERATING PRINCIPLE

The Drag Torque or Detent Torque is an important parameter in Permanent Magnet (PM) motors, especially in a PM servo motor system. The Detent Torque of PM motors is composed of Cogging Torque and Friction Torque. The Cogging Torque is generated by attraction/interaction of the magnetic poles to the teeth (steel structure) within an un-energized motor. It is one of the most important parameters of permanent magnet

motors, which causes torque ripple, vibration and noise. Generally the cogging torque varies with rotor position and is defined by its peak to peak (p-p) value. Friction Torque is attributed to mechanical assembly issues, such as bearing resistance, assembly tolerance, or carbon-brush friction for brush PM DC (PMDC) motors. Friction Torque is commonly measured by its average value.

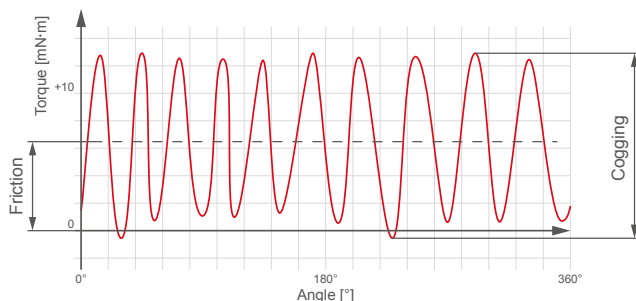

Fig. 2: Example of typical curve for cogging. Friction is an average value calculated from 0 torque. Cogging value is calculated on the peak torque value.

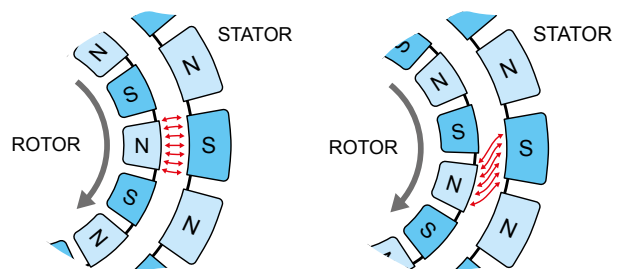

Fig. 3: When the magnets are face-to-face (above left), the force is maximized. When the motor is running (above right), the moving magnetic elements will first have to free themselves from the residual magnetism before proceeding to the next step. This resistance to advancement is named cogging.

DESCRIPTION

Magtrol's Cogging Test System is a stand-alone test system designed to control and measure Detent Torque, Cogging Torque and Friction Torque. The test System includes a precision geared motor, a TS Series Torque Sensor integrating a 5000 pulses encoder. CTS 100 to CTS 102 have a built-in security clutches to avoid system overload by mishandling when not in use. The geared motor drives the MUT (Motor Under Test) at a low speed from 1 to 10rpm (respectively 8rpm for CTS 103 and CTS 104), while acquiring its cogging torque related to angle position. The torque measurement covers a range up to 1 N·m (depending on the selected torque sensor) with an accuracy of ± 0.1 mN·m (for TS 100-50 mN·m and TS 101-100 mN·m). The executable software controls the system and displays acquired data. It provides accurate peak-to-peak measurement of cogging torque and displays X-Y or polar graphs as well as FFT analysis. The software allows the storage of measured data and provides comparison of performance data by overlaying up to 5 graphs. A cursor can be used to read accurate values from measurement points. Measured parameters can be saved as text file TXT. For better accuracy and function control, the software includes a zero offset adjustment routine which checks transducer signal over a complete turn (test sample MUT not connected to the system).

As a stand-alone system, the CTS only requires 100-240 VAC power. A USB interface allows direct connection to the PC on which the software is installed. It is mounted on a PT-25 grooved base plate on which the motor fixture can be fitted. Vertical mounting bracket are available as an option, allowing to mount the system in vertical position, which is particularly recommended for very low measuring values.

Models CTS 100 to CTS 102 can easily be scaled up or down (50, 100 or 200 mNm), simply by replacing the TS Sensor which is mounted in front of the unit. The software will recognize the torque sensor being in use and will automatically adapt its measuring range.

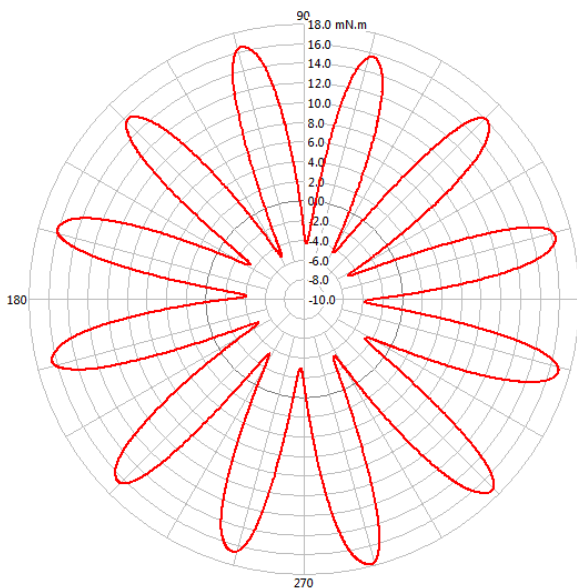

Fig. 4: Example of polar plot

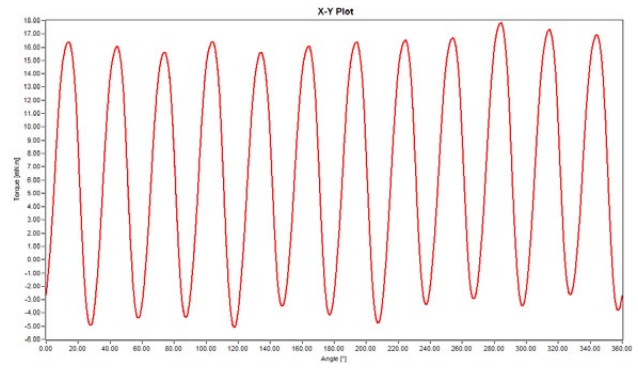

Fig. 5: Example of X-Y plot

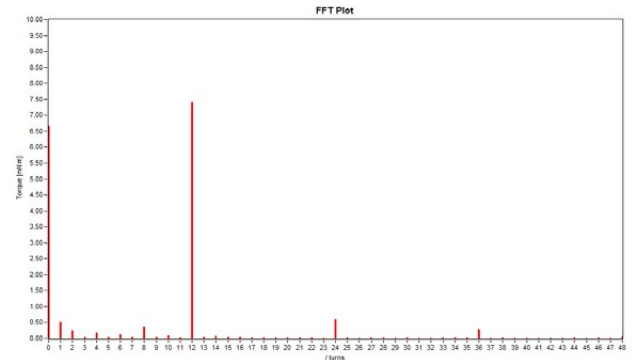

Fig. 6: Example of FFT plot

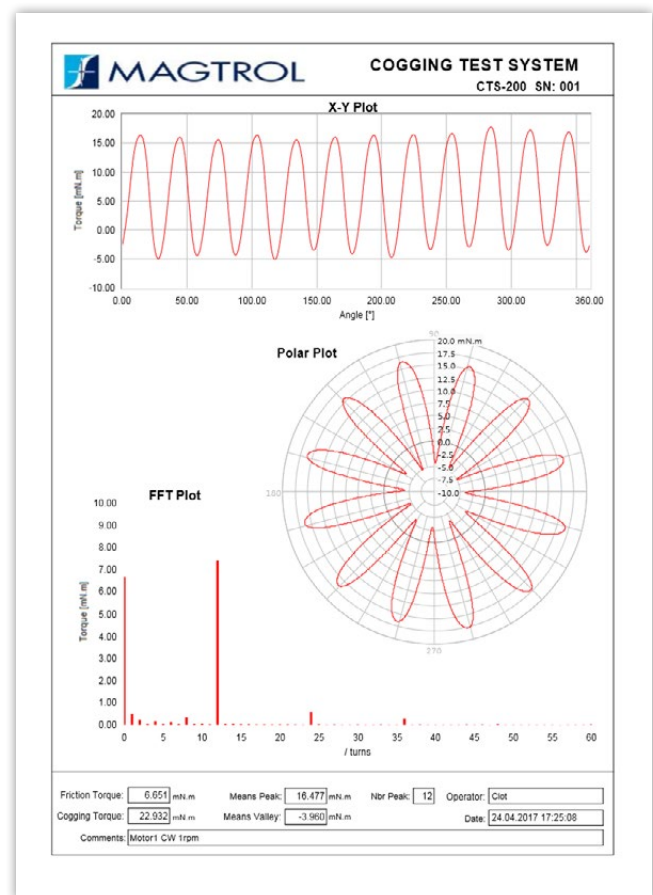

Fig. 8: Example of compiled report, can be used as certificate.

SPECIFICATIONS

MECHANICAL CHARACTERISTICS					
MODEL	CTS 100	CTS 101	CTS 102	CTS 103	CTS 104
Rated torque (RT) ^{a)}	50 mN·m	100 mN·m	200 mN·m	500 mN·m	1000 mN·m
Accuracy	0.2% of RT	0.1% of RT			
Scalability of the measuring range	Yes ^{b)}			No	
MEASUREMENT					
Speed range	1 to 10rpm			1 to 8rpm	
Angle detection	0.018° (5000 pulses per revolution)				
Direction of rotation	Clockwise & Counter Clockwise				
ENVIRONMENT					
Operating temperature range	+10 °C to +45 °C				
Storage temperature range	0 °C to +70 °C				
Temperature influence on zero	0.01 % / °C				
Protection class	IP42				
ELECTRICAL CHARACTERISTICS					
Power supply	100-240 VAC / 50-60 Hz (max. 1 A)				
Connection interface	USB-B 2.0				
Connection cable	2 m cable (USB-A/USB-B) included				

a) other ranges available on request

b) Can easily be scaled up or down (50, 100 or 200mNm), by replacing the TS Sensor which is mounted in front of the unit. The software will recognize the torque sensor being in use and will automatically adapt its measuring range.

DIMENSIONS

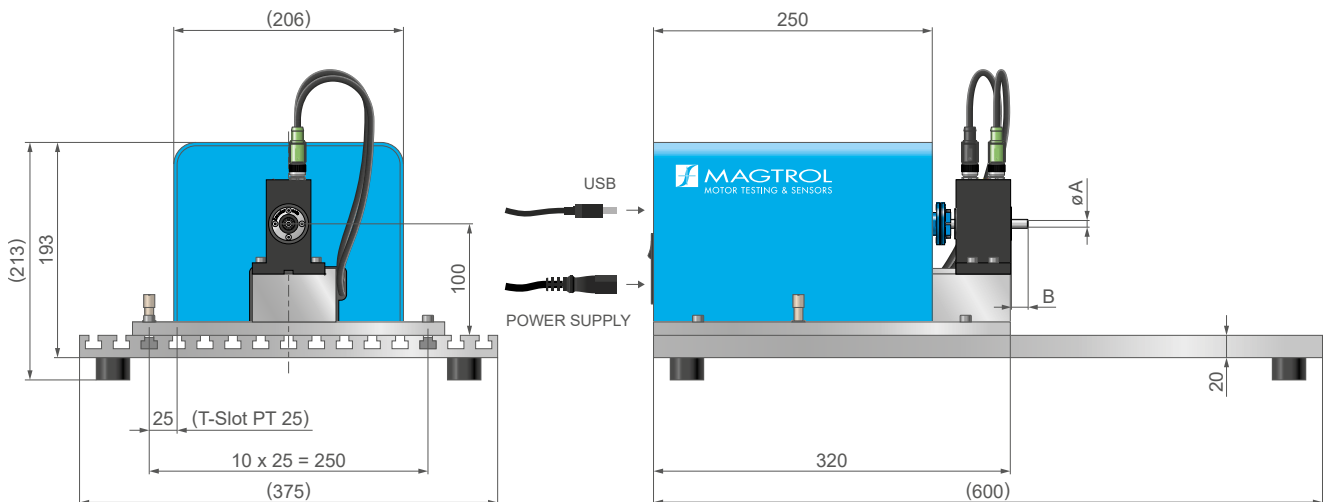

NOTE: All values are in metric units.

MODEL	TORQUE [mN·m]	øAg6	B
CTS 100	50	ø6 g6 ^(-0.004) _(-0.012)	15.0
CTS 101	100		
CTS 102	200		
CTS 103	500	ø8 g6 ^(-0.005) _(-0.014)	17.1
CTS 104	1000		

NOTE: 3D STEP files of most of our products are available on our website: www.magtrol.com ; other files are available on request.

SYSTEM OPTIONS

VERTICAL MOUNTING KIT

To ensure optimal value acquisition in the lower measurement ranges (mainly with the CTS 100-50 mN·m), it is strongly recommended to use the system in a vertical position.

Magtrol offers (as an option) a vertical mounting kit with accessory. This kit can be used with all CTS models.

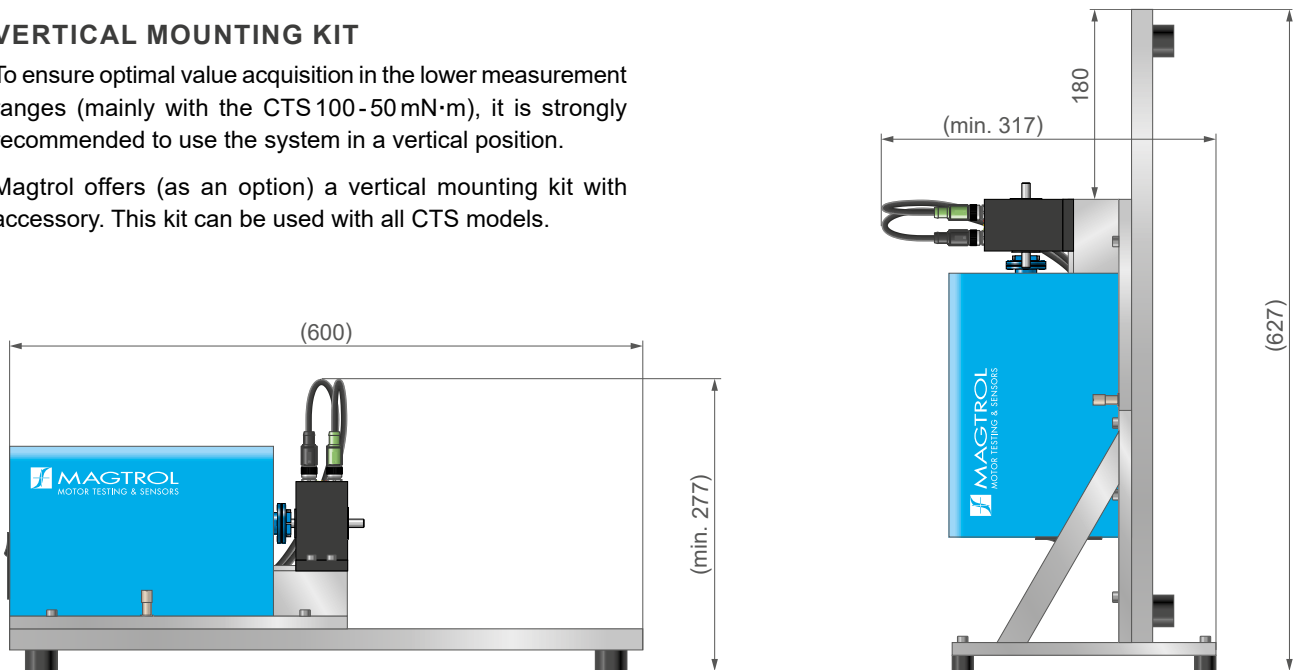

MOTOR FIXTURES

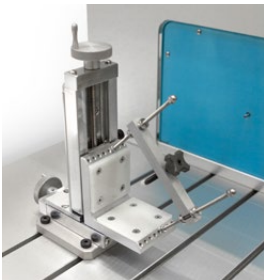

Positioning and alignment have a great influence on the measured parameters (friction torque). MAGTROL strongly recommended to provide a support specifically dedicated to the products to be tested to ensure the best positioning tolerances in X-Y, and its repeatability.

Alternatively, Magtrol AMF Series (Adjustable Motor Fixtures) can be used. These extremely versatile fixtures can accommodate motors up to 101 mm (4 ") in diameter. It enables easy motor centering during testing, but does not have centering references.

ORDERING INFORMATION

ORDERING NUMBER 843 - ___ - 000 - 011

- 100 : CTS 100 (50 mN·m)
- 101 : CTS 101 (100 mN·m)
- 102 : CTS 102 (200 mN·m)
- 103 : CTS 103 (500 mN·m)
- 104 : CTS 104 (1000 mN·m)

CTS - Vertical Mounting Kit 843-100-900-011

Example: CTS 101 cogging test system 100 mN·m would be ordered as : 843-100-000-011.