

Volumetric synchronous dosing and mixing station

SPECTROCOLOR V

 think materials management



SPECTROCOLOR V

VOLUMETRIC SYNCHRONOUS DOSING AND MIXING STATION

SPECTROCOLOR V with 10L collecting bin and three dosing modules



SPECTROCOLOR V with two dosing modules



SPECTROCOLOR V

With the volumetric dosing and mixing station SPECTROCOLOR V, motan offers a simple solution for the economic production of plastics parts: precise dosing and homogeneous mixing with highest repeatability.

Either as a central mixing station or mounted on the processing machine, they dose and mix up to six materials in granular form. They operate according to the motan gravity mixing principle.

The dosing modules are simultaneously controlled by a microprocessor control. The inclined dosing screws provide a continuous and accurate material feed.

A level sensor monitors the material level and, as material is required the dosing modules start simultaneously to deliver the required amounts.

Modular design

Due to the modular design of the SPECTROCOLOR V, the supply hoppers and dosing modules can be removed without tools. Therefore, cleaning and quick change-over to other materials is easy. Depending on the application, different dosing modules with different screw sizes and supply hopper sizes are available.

Dosing module and supply hopper

The inclined dosing screw prevents material trickle due to movement of the processing machine. For cleaning, the dosing screw is simply removed. The dosing motor is swivel mounted and can be moved out of the way while changing the screw and supply hopper. This simplifies handling for the user. The dosing screws are supported at one end. Thus, material jams at the screw discharge are avoided. The quick-change system for dosing screws ensures that the dosing modules suit different throughputs and materials.

Quick change system



One-sided bearing mounted dosing screw with quick release connection



Gravity mixing principle



Unbeatable mixing quality

motan's unique gravity-mixing principle offers a high level of mix consistency of the components before they reach the extruder. This plays a key role in achieving perfect plasticisation and homogenisation of the materials.

VOLUnet SC control



VOLUnet control

- Easy to understand instructions on the full colour touch screen
- Ethernet compatible, therefore easy to integrate into motan's CONTROLnet
- Up to 50 recipes possible
- Documentation (recipe report, shift report)
- Convey control as option for 7 hopper loaders and 2 blowers or alternatively 1 blower and 1 standby blower; further options through interprocess communication.

SPECTROCOLOR V

TECHNICAL DATA

Technical data			
Dosing and mixing station	SPECTROCOLOR V		
	200		1200
Collecting bin (l)	10 (SC10)		40 (SC40)
Number of supply hoppers			
15 l	1 - 4		1 - 6
40 l	–		1 - 5
B60	x		–
B100	–		x
Connected load (W)		500	
Dosing screw type (kg/h) (l/h) i = 24:1			
G12S	0.15-3.0 0.25-5.0		0.15-3.0 0.25-5.0
G20S	1.5-30.0 2.6-51.5		1.5-30.0 2.6-51.5
G26S/L	3.5-70.0 5.8-116.0		3.5-70.0 5.8-116.0
G52S/L	35.0-500.0 58.0-835.0		35.0-500.0 58.0-835.0
G78L	–		80.0-1200.0 133.0-2000.0
Power supply (V/Hz)	1/N/PE 230/50		1/N/PE 230/50
Dimensions (mm)			
L1	736		930
B1	970		1022
H1	700		882
Weight approx. (kg)	150		130
Colour RAL (orange/grey)	2011/7040		2011/7040

All throughputs are calculated assuming a free flowing granular material with a bulk density of 0.6 kg/dm³.

Subject to technical changes.

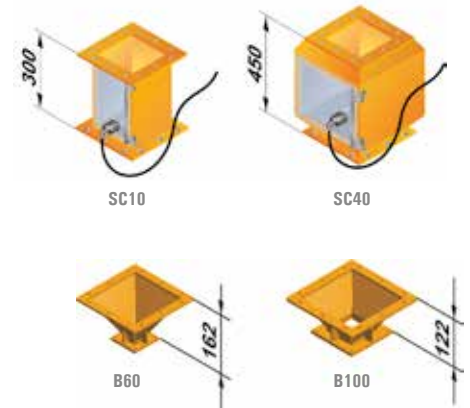
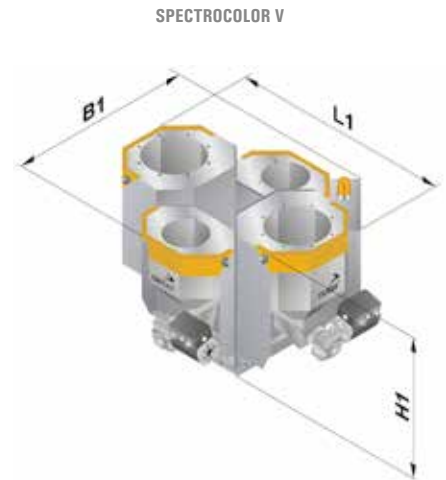

All dimensions in mm.

YOUR BENEFITS

Cost savings through

- saving additives
- fast material changes
- high productivity
- constant dosing throughout

Production reliability through

- simple calibration
- high repeatability
- simple operation with micro-processor control
- parts in contact with material made of stainless steel
- simple cleaning
- wear-free dosing drive

To find your local partner, please visit our website.

