

C-Lube Linear Roller Way Super MX Linear Roller Way Super X

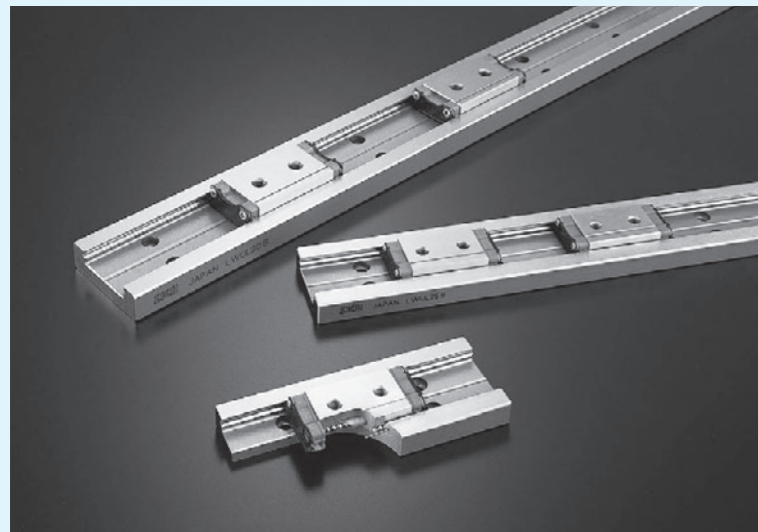

C-Lube Linear Roller Way Super MX

MX



long term maintenance free supported!

The aquamarine end plate is the symbol of maintenance free.

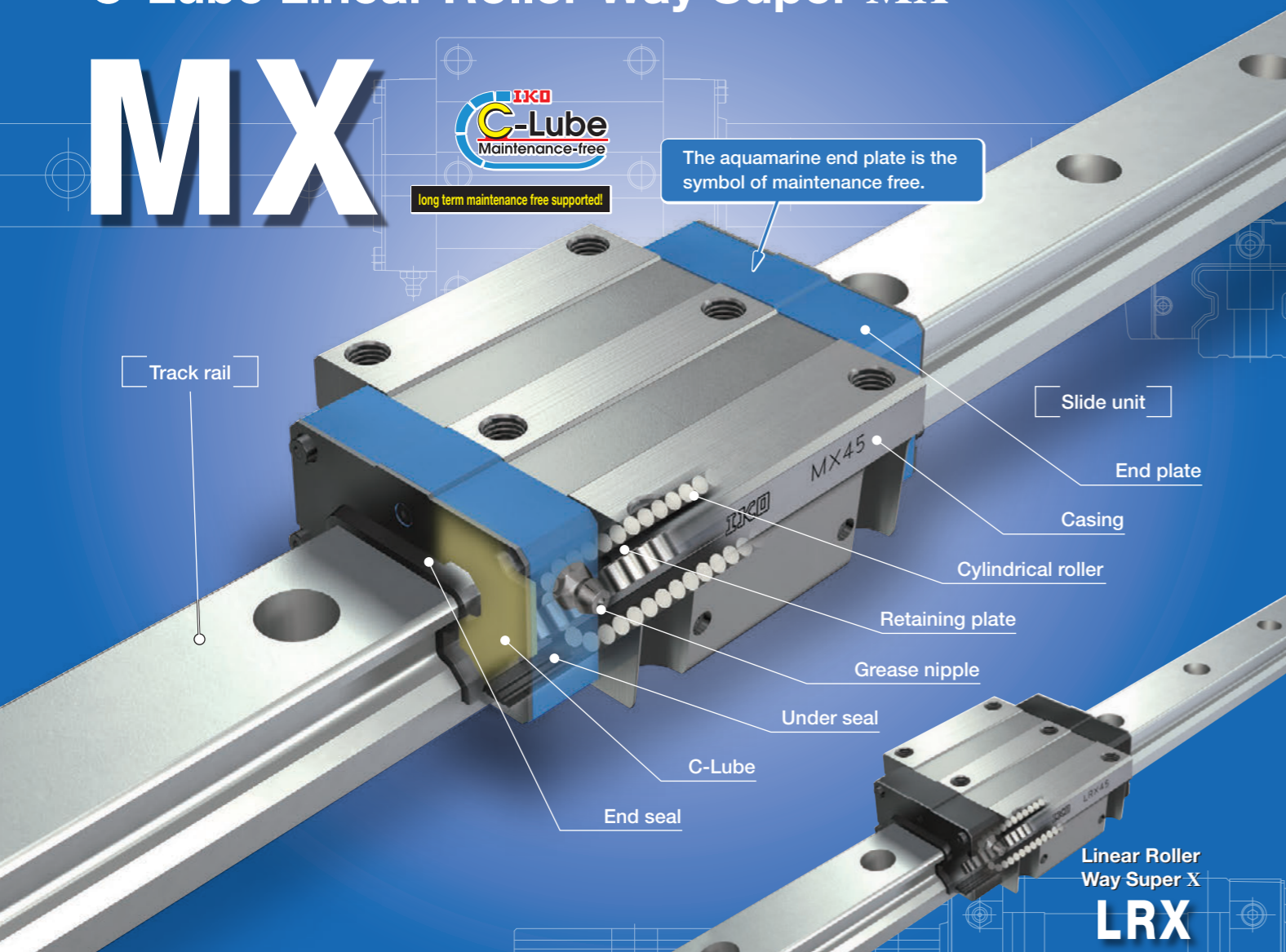

Points

- **Roller type linear motion rolling guides having the highest level of rolling guide performance** For details ▶ P.I-21

Linear motion rolling guide that has achieved the highest level of performance in all characteristics, including load capacity, rigidity, friction characteristics and accuracy, brought about by utilizing the roller's excellent characteristic.

- **Wide range of variations for your needs** For details ▶ P.I-28

A wide variety of products, including five types of different slide unit shape such as the flange type, low profile flange type and low profile block type with low cross sectional height, etc., and four types of different slide unit length with varying lengths with same section are available. You can select an optimal product for the specifications of your machine and device.

- **Extra long unit** For details ▶ P.I-29

Extra long slide unit series having the length 1.4 to 1.5 times of standard type is now available. With more rollers built into the slide units, the new series not only have the enhanced load capacity and rigidity but also exhibit super accuracy running performance.

- **Stainless steels selections superior in corrosion resistance are listed on lineup.** For details ▶ P.I-41

A series of stainless steel products is available from the miniature size of track rail width 10 mm. They are highly corrosion-resistant and suitable for applications where rust prevention oil is not preferred, such as in cleanroom environment.

- **Easy replacement from ball type** For details ▶ P.I-24

Mounting dimensions are compatible with MH / LWH series of ball type. Therefore, replacement to roller type is possible without major design changes of machine and device.

Identification Number and Specification

Example of an identification number

The specifications of MX and LRX series are indicated by the identification number. Indicate the identification number, consisting of a model code, dimensions, a part code, a material code, a preload symbol, a classification symbol, an interchangeable code, and any supplemental codes for each specification to apply.

Non-interchangeable specification	1	2	3	4	5	6	7	8	9	10
Assembled set	MX	G	15	C2	R240		T ₁	P		/Z
Interchangeable specification										
Single slide unit	MX	G	15	C1			T ₁	P	S1	/Z
Single track rail (*)	LRX		15		R240			P	S1	
Assembled set	MX	G	15	C2	R240		T ₁	P	S1	/Z

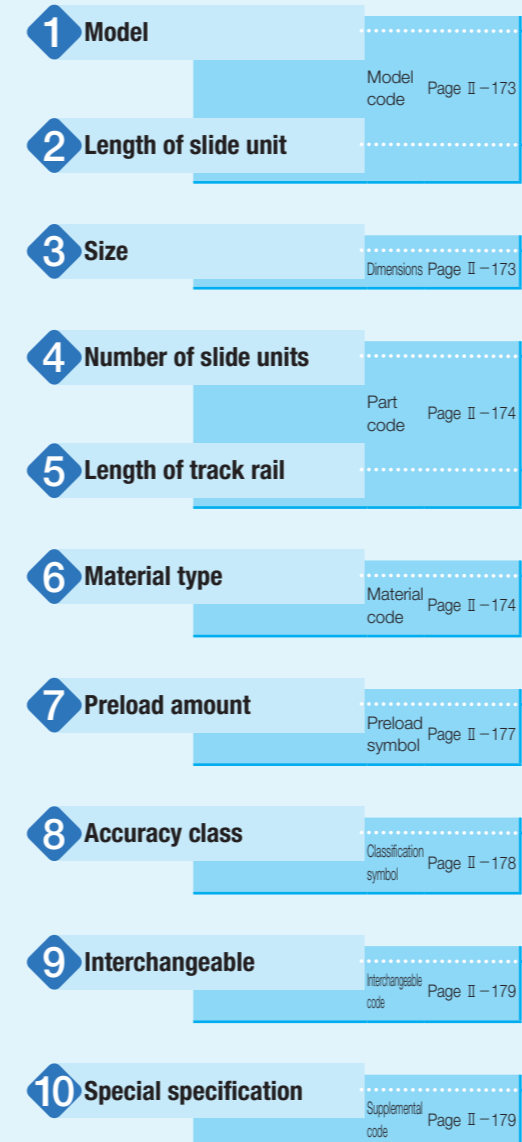

Note (*) Indicate "LRX" for the model code of the single track rail regardless of the series and the combination of slide unit model.

Identification Number and Specification — Model · Length of Slide Unit · Size —

1 Model

C-Lube Linear Roller Way Super MX (MX series) Flange type mounting from top / bottom : MX ⁽²⁾
 Block type mounting from top : MXD
 Compact block type mounting from top : MXS
 Low profile flange type mounting from top : MXN
 Low profile block type mounting from top : MXNS

Linear Roller Way Super X ⁽¹⁾ (LRX series) Flange type mounting from top / bottom : LRX ⁽²⁾
 Block type mounting from top : LRXD
 Compact block type mounting from top : LRXS

For applicable models and sizes, see Table 1.1 and Table 1.2.
 Indicate "LRX" for the model code of the single track rail regardless of the series and the combination of slide unit models.

Notes ⁽¹⁾ This model has no built-in C-Lube.
⁽²⁾ Series of size 20 can only be mounted by the bolts from top. The models with the same dimensions allowing mounting from bottom are "MXH" and "LRXH."

2 Length of slide unit

Short : C For applicable models and sizes, see Table 1.1 and Table 1.2.
 Standard : No symbol
 Long : G
 Extra long : L

3 Size

10, 12, 15, 20, 25, 30, 35, 45, 55, 65, 85, 100 For applicable models and sizes, see Table 1.1 and Table 1.2.

Table 1.1 Models and sizes of MX and LRX series

Material	Shape	Slide unit Length	Model	Size																									
				10	12	15	20	25	30	35	45	55	65	85	100														
High carbon steel made	Flange type mounting from top / bottom	Short	MXC	-	○	○	○ ⁽¹⁾	○	○	○	○	○	○	-	-	LRXC	-	○	○	○ ⁽¹⁾	○	○	○	○	○	○	-	-	
			MX	-	○	○	○ ⁽¹⁾	○	○	○	○	○	○	○	-	-	LRX	-	○	○	○ ⁽¹⁾	○	○	○	○	○	○	-	-
		Long	MXG	-	○	○	○ ⁽¹⁾	○	○	○	○	○	○	○	-	-	LRXG	-	○	○	○ ⁽¹⁾	○	○	○	○	○	○	-	-
			MXL	-	-	-	○ ⁽¹⁾	○	○	○	○	○	○	○	-	-	LRXL	-	-	-	-	-	-	-	-	-	○	-	-
		Extra long	MXDC	-	○	○	○	○	○	○	○	○	○	○	-	-	LRXDC	-	○	○	○	○	○	○	○	○	○	-	-
			MXD	-	○	○	○	○	○	○	○	○	○	○	-	-	LRXD	-	○	○	○	○	○	○	○	○	○	-	-
	Block type mounting from top	Standard	MXDG	-	○	○	○	○	○	○	○	○	○	-	-	LRXDG	-	○	○	○	○	○	○	○	○	○	-	-	
			MXDL	-	-	-	○	○	○	○	○	○	○	○	-	-	LRXDL	-	-	-	-	-	-	-	-	-	○	-	-
		Long	MXNS	-	-	-	-	-	○	○	○	○	○	-	-	MXNSG	-	-	-	-	-	○	○	○	○	-	-	-	
			MXN	-	-	-	-	-	○	○	○	○	○	-	-	MXNL	-	-	-	-	-	○	○	○	○	-	-	-	
		Extra long	MXNG	-	-	-	-	-	○	○	○	○	○	-	-	MXNSL	-	-	-	-	-	○	○	○	○	-	-	-	
			MXNL	-	-	-	-	-	○	○	○	○	○	-	-	LRXDC...SL	-	○	○	○	○	○	○	-	-	-	-	-	-
	Stainless steel made	Block type mounting from top	Standard	MXD...SL	○	○	○	○	○	○	○	○	-	-	-	-	LRXD...SL	○	○	○	○	○	○	○	-	-	-	-	-
			Long	LRXDG...SL	-	○	○	○	○	○	○	○	○	-	-	-	-												

Note ⁽¹⁾ MXC20, MX20, MXG20, MXL20, LRXC20, LRX20 and LRXG20 can only be mounted by the bolts from top.
 The models with the same dimensions allowing mounting from bottom are MXHC20, MXH20, MXHG20, MXHL20, LRXHC20, LRXH20 and LRXHG20.
 Remark: For the models indicated in , the interchangeable specification is available.

— Number of Slide Unit · Length of Track Rail · Material Type —

4 Number of slide units : C○ For an assembled set, indicates the number of slide units assembled on a track rail. For a single slide unit, only "C1" is specified.

5 Length of track rail : R○ Indicate the length of track rail in mm. For the standard and maximum lengths, see Table 2.1, Table 2.2, Table 2.3 and Table 2.4.

6 Material type
 High carbon steel made : No symbol For applicable models and sizes, see Table 1.1 and Table 1.2.
 Stainless steel made ⁽¹⁾ : SL

Note ⁽¹⁾ Mount a standard grease nipple (brass) on the stainless steel type, too. Stainless steel grease nipple is also available. If needed, please contact IKO.

Table 1.2 Models and sizes of MX and LRX series

Material	Shape	Slide unit Length	Model	Size																								
				10	12	15	20	25	30	35	45	55	65	85	100													
High carbon steel made	Compact block type mounting from top	Short	MXSC	-	-	○	○	○	○	-	-	-	-	-	LRXSC	-	-	○	○	○	○	-	-	-	-	-		
			MXS	-	-	○	○	○	○	○	○	○	-	-	LRXS	-	-	○	○	○	○	-	-	-	-	-		
		Standard	MXSG	-	-	○	○	○	○	○	○	○	-	-	LRXSG	-	-	○	○	○	○	-	-	-	-	-		
			MXSL	-	-	-	○	○	○	○	○	○	-	-														
		Long	MXNS	-	-	-	-	-	○	○	○	○	-	-	MXNSG	-	-	-	-	-	○	○	○	○	-	-	-	
			MXN	-	-	-	-	-	○	○	○	○	-	-	MXNL	-	-	-	-	-	○	○	○	○	-	-	-	
	Extra long	MXNG	-	-	-	-	-	○	○	○	○	-	-	MXNSL	-	-	-	-	-	○	○	○	○	-	-	-		
		MXNL	-	-	-	-	-	○	○	○	○	-	-	LRXDC...SL	-	○	○	○	○	○	○	-	-	-	-	-		
	Stainless steel made	Block type mounting from top	Standard	MXD...SL	○	○	○	○	○	○	○	○	-	-	-	LRXD...SL	○	○	○	○	○	○	○	-	-	-	-	-
			Long	LRXDG...SL	-	○	○	○	○	○	○	○	-	-	-													

Remark: For the models indicated in , the interchangeable specification is available.

Table 2.1 Standard and maximum length of high carbon steel track rail

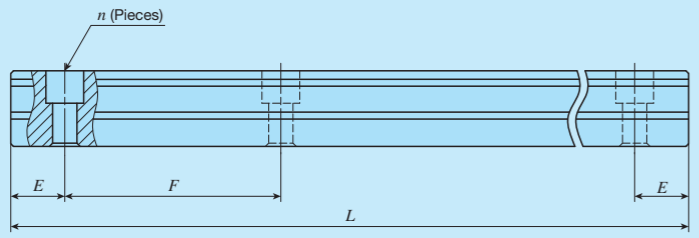

Item	Identification number	MX 12 LRX12	MX 15 LRX15	MX 20 LRX20	MX 25 LRX25	MX 30 LRX30	MX 35 LRX35
Standard length L (n)		80 (2)	180 (3)	240 (4)	240 (4)	480 (6)	480 (6)
		160 (4)	240 (4)	480 (8)	480 (8)	640 (8)	640 (8)
		240 (6)	360 (6)	660 (11)	660 (11)	800 (10)	800 (10)
		320 (8)	480 (8)	840 (14)	840 (14)	1 040 (13)	1 040 (13)
		400 (10)	660 (11)	1 020 (17)	1 020 (17)	1 200 (15)	1 200 (15)
		480 (12)		1 200 (20)	1 200 (20)	1 520 (19)	1 520 (19)
		560 (14)		1 500 (25)	1 500 (25)		
		640 (16)					
		720 (18)					
Pitch of mounting holes F		40	60	60	60	80	80
E		20	30	30	30	40	40
Standard E dimensions (1)	or higher	5.5	7	8	9	10	10
	below	25.5	37	38	39	50	50
Maximum length (2)		1 480	1 500 (1 980)	1 980 (3 000)	3 000 (3 960)	2 960 (4 000)	2 960 (4 000)

Item	Identification number	MX 45 LRX45	MX 55 LRX55	MX 65 LRX65	LRX85	LRXG100
Standard length L (n)		840 (8)	840 (7)	1 500 (10)	1 620 (9)	1 500 (10)
		1 050 (10)	1 200 (10)	1 950 (13)	1 980 (11)	1 950 (13)
		1 260 (12)	1 560 (13)	3 000 (20)	2 340 (13)	3 000 (20)
		1 470 (14)	1 920 (16)		2 700 (15)	
		1 995 (19)	3 000 (25)			
Pitch of mounting holes F		105	120	150	180	150
E		52.5	60	75	90	75
Standard E dimensions (1)	or higher	12.5	15	17	23	29
	below	65	75	92	113	104
Maximum length (2)		2 940 (3 990)	3 000 (3 960)	3 000 (3 900)	2 880	3 000

Notes (1) This does not apply to female threads for bellows (Supplemental code "/J").
 (2) Length up to the value in () can be produced. If needed, please contact IKO.
 Remarks 1. A typical identification number is indicated, but is applied to all models of the same size.
 2. Indicate "LRX" for the model code of the single track rail regardless of the series and the combination of slide unit models.
 3. In the case where track rail mounting hole is half pitch specification (Supplemental code "/HP"), see Table 2.3.
 4. If not directed, E dimensions for both ends will be the same within the range of standard E dimensions. To change the dimensions, indicate the specified rail mounting hole positions " E " of special specification. For more information, see page III-30.

Table 2.2 Standard and maximum length of stainless steel track rail

Item	Identification number	MXD 10...SL LRXD10...SL	MX 12...SL LRX12...SL	MX 15...SL LRX15...SL	MX 20...SL LRX20...SL	MX 25...SL LRX25...SL	MX 30...SL LRX30...SL
Standard length L (n)		50 (2)	80 (2)	180 (3)	240 (4)	240 (4)	480 (6)
		100 (4)	160 (4)	240 (4)	480 (8)	480 (8)	640 (8)
		150 (6)	240 (6)	360 (6)	660 (11)	660 (11)	800 (10)
		200 (8)	320 (8)	480 (8)	840 (14)	840 (14)	1 040 (13)
		250 (10)	400 (10)	660 (11)			
		300 (12)	480 (12)				
		350 (14)	560 (14)				
		400 (16)	640 (16)				
		450 (18)	720 (18)				
		500 (20)					
Pitch of mounting holes F		25	40	60	60	60	80
E		12.5	20	30	30	30	40
Standard E dimensions (1)	or higher	5	5.5	7	8	9	10
	below	17.5	25.5	37	38	39	50
Maximum length (2)		850 (1 000)	1 000 (1 480)	1 200 (1 980)	1 200 (1 980)	1 200 (1 980)	1 200 (2 000)

Notes (1) This does not apply to female threads for bellows (Supplemental code "/J").
 (2) Length up to the value in () can be produced. If needed, please contact IKO.
 Remarks 1. A typical identification number is indicated, but is applied to all models of the same size.
 2. Indicate "LRX" for the model code of the single track rail regardless of the series and the combination of slide unit models.
 3. In the case where track rail mounting hole is half pitch specification (Supplemental code "/HP"), see Table 2.4.
 4. If not directed, E dimensions for both ends will be the same within the range of standard E dimensions. To change the dimensions, indicate the specified rail mounting hole positions " E " of special specification. For more information, see page III-30.

Table 2.3 Standard and maximum length of high carbon steel track rail (Half pitch mounting holes specification supplemental code /HP)



Item	Identification number	MX 12.../HP LRX12.../HP	MX 15.../HP LRX15.../HP	MX 20.../HP LRX20.../HP	MX 25.../HP LRX25.../HP	MX 30.../HP LRX30.../HP	MX 35.../HP LRX35.../HP
Standard length L (n)		80 (4)	180 (6)	240 (8)	480 (16)	480 (12)	480 (12)
		160 (8)	240 (8)	480 (16)	660 (22)	640 (16)	640 (16)
		240 (12)	360 (12)	660 (22)	840 (28)	800 (20)	800 (20)
		320 (16)	480 (16)	840 (28)	1 020 (34)	1 040 (26)	1 040 (26)
		400 (20)	660 (22)	1 020 (34)	1 200 (40)	1 200 (30)	1 200 (30)
		480 (24)		1 200 (40)	1 500 (50)	1 520 (38)	1 520 (38)
		560 (28)		1 500 (50)			
		640 (32)					
		720 (36)					
	Pitch of mounting holes F		20	30	30	30	40
E		10	15	15	15	20	20
Standard E dimensions (1)	or higher	5.5	7	8	9	10	10
	below	15.5	22	23	24	30	30
Maximum length (2)		1 480	1 500 (1 980)	1 980 (3 000)	3 000 (3 960)	2 960 (4 000)	2 960 (4 000)

Item	Identification number	MX 45.../HP LRX45.../HP	MX 55.../HP LRX55.../HP	MX 65.../HP LRX65.../HP	LRX85.../HP
Standard length L (n)		840 (16)	840 (14)	1 500 (20)	1 620 (18)
		1 050 (20)	1 200 (20)	1 950 (26)	1 980 (22)
		1 260 (24)	1 560 (26)	3 000 (40)	2 340 (26)
		1 470 (28)	1 920 (32)		2 700 (30)
		1 995 (38)	3 000 (50)		
Pitch of mounting holes F		52.5	60	75	90
E		26.25	30	37.5	45
Standard E dimensions (1)	or higher	12.5	15	17	23
	below	38.75	45	54.5	68
Maximum length (2)		2 940 (3 990)	3 000 (3 960)	3 000 (3 900)	2 970

Notes (1) This does not apply to female threads for bellows (Supplemental code "/J").
 (2) Length up to the value in () can be produced. If needed, please contact IKO.
 Remarks 1. A typical identification number is indicated, but is applied to all models of the same size.
 2. Indicate "LRX" for the model code of the single track rail regardless of the series and the combination of slide unit models.
 3. If not directed, E dimensions for both ends will be the same within the range of standard E dimensions. To change the dimensions, indicate the specified rail mounting hole positions " E " of special specification. For more information, see page III-30.

Table 2.4 Standard and maximum length of stainless steel track rail (Half pitch mounting holes specification supplemental code /HP)

Item	Identification number	MX 12...SL/HP LRX12...SL/HP	MX 15...SL/HP LRX15...SL/HP	MX 20...SL/HP LRX20...SL/HP	MX 25...SL/HP LRX25...SL/HP	MX 30...SL/HP LRX30...SL/HP
Standard length L (n)		80 (4)	180 (6)	240 (8)	480 (16)	480 (12)
		160 (8)	240 (8)	480 (16)	660 (22)	640 (16)
		240 (12)	360 (12)	660 (22)	840 (28)	800 (20)
		320 (16)	480 (16)	840 (28)		1 040 (26)
		400 (20)	660 (22)			
		480 (24)				
		560 (28)				
		640 (32)				
		720 (36)				
	Pitch of mounting holes F		20	30	30	30
E		10	15	15	15	20
Standard E dimensions (1)	or higher	5.5	7	8	9	10
	below	15.5	22	23	24	30
Maximum length (2)		1 000 (1 480)	1 200 (1 980)	1 200 (1 980)	1 200 (1 980)	1 200 (2 000)

Notes (1) This does not apply to female threads for bellows (Supplemental code "/J").
 (2) Length up to the value in () can be produced. If needed, please contact IKO.
 Remarks 1. A typical identification number is indicated, but is applied to all models of the same size.
 2. Indicate "LRX" for the model code of the single track rail regardless of the series and the combination of slide unit models.
 3. If not directed, E dimensions for both ends will be the same within the range of standard E dimensions. To change the dimensions, indicate the specified rail mounting hole positions " E " of special specification. For more information, see page III-30.

—Preload Amount—

7 Preload amount	Standard	: No symbol	Specify this item for an assembled set or a single slide unit.
	Light preload	: T ₁	
	Medium preload	: T ₂	For details of the preload amount, see Table 3.
	Heavy preload	: T ₃	For applicable preload types, see Table 4.

Table 3 Preload amount

Preload type	Item	Preload symbol	Preload amount N	Operational conditions
Standard	(No symbol)	0 ⁽¹⁾		• Light and precise motion
Light preload	T ₁	0.02 C ₀		• Almost no vibrations • Load is evenly balanced • Light and precise motion
Medium preload	T ₂	0.05 C ₀		• Medium vibration • Medium overhung load
Heavy preload	T ₃	0.08 C ₀		• Operation with vibration and/or shock • Overhanging load applied • Heavy cutting

Note ⁽¹⁾ Indicates zero or minimal amount of preload.
Remark: C₀ indicates the basic static load rating.

Table 4 Application of preload

Size	Preload type (preload symbol)			
	Standard (No symbol)	Light preload (T ₁)	Medium preload (T ₂)	Heavy preload (T ₃)
10	○	○	—	—
12	○	○	○	○
15	○	○	○	○
20	○	○	○	○
25	○	○	○	○
30	○	○	○	○
35	○	○	○	○
45	○	○	○	○
55	○	○	○	○
65	○	○	○	○
85	○	○	○	○
100	○	○	○	○

Remark: The mark indicates that interchangeable specification products are available.

—Accuracy Class—

8 Accuracy class	High	: H	For interchangeable specification products, assemble a slide unit and a track rail of the same accuracy class.
	Precision	: P	For details of accuracy class, see Table 5.
	Super precision	: SP	
	Ultra precision	: UP	For applicable accuracy class, see Table 6.

Table 5 Tolerance and allowance

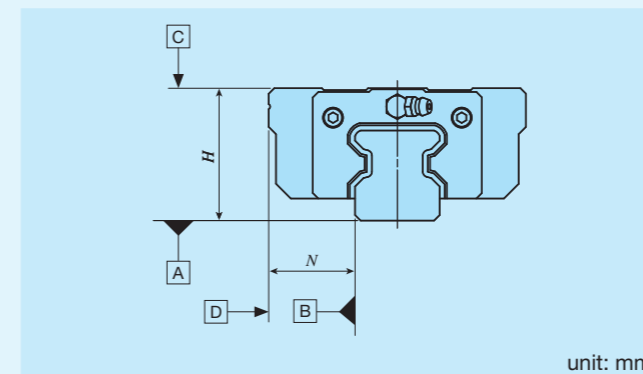

Item	Class (classification symbol)			
	High (H)	Precision (P)	Super precision (SP)	Ultra precision (UP)
Dim. H tolerance	±0.040	±0.020	±0.010	±0.008
Dim. N tolerance	±0.050	±0.025	±0.015	±0.010
Dim. variation of H ⁽¹⁾	0.015	0.007	0.005	0.003
Dim. variation of N ⁽¹⁾	0.020	0.010	0.007	0.003
Dim. variation of H for multiple assembled sets ⁽²⁾	0.035	0.025	—	—
Parallelism in operation of the slide unit C surface to A surface	See Fig. 1			
Parallelism in operation of the slide unit D surface to B surface	See Fig. 1			

Notes ⁽¹⁾ It means the size variation between slide units mounted on the same track rail.
⁽²⁾ Applicable to the interchangeable specification.

Table 6 Application of accuracy class

Size	Class (classification symbol)			
	High (H)	Precision (P)	Super precision (SP)	Ultra precision (UP)
10	○	○	○	○
12	○	○	○	○
15	○	○	○	○
20	○	○	○	○
25	○	○	○	○
30	○	○	○	○
35	○	○	○	○
45	○	○	○	○
55	○	○	○	○
65	○	○	○	○
85	○	○	○	○
100	○	○	○	○

Remark: The mark indicates that interchangeable specification products are available.

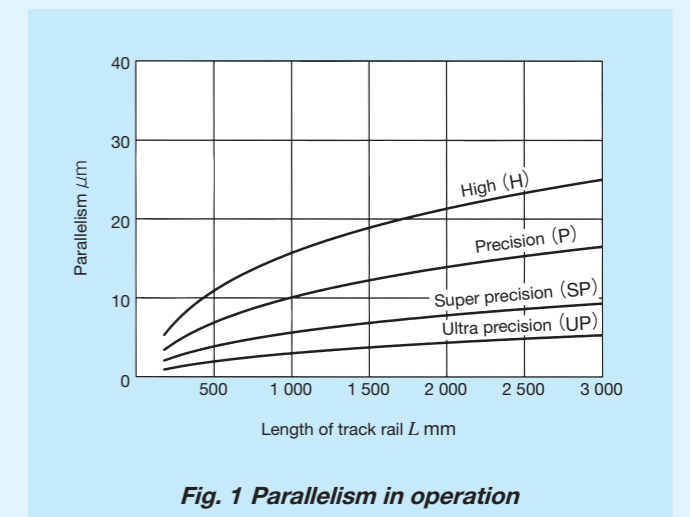

Fig. 1 Parallelism in operation

9 Interchangeable	S1 specification : S1	This is specified for the interchangeable specifications.
	S2 specification : S2	Assemble a track rail and a slide unit with the same interchangeable code. When using in combination with different interchangeable codes, please contact IKO. Note that the combination of interchangeable codes will not have any effect on accuracy.
	Non-interchangeable specification : No symbol	For applicable models and sizes, see Table 1.1 and Table 1.2. "No symbol" is indicated for non-interchangeable specification.

10 Special specification	/A, /D, /E, /F, /GE, /HP, /I, /JO, /LO, /LFO, /MA, /MN, /N, /PS, /Q, /RCO, /T, /UR, /VO, /WO, /YO, /ZO	For applicable special specifications, see Tables 7.1, 7.2, 7.3, and 7.4. For combination of multiple special specifications, see Table 8. For details of special specifications, see page III – 29.
---------------------------------	--	--

Table 7.1 Application of special specifications (Interchangeable specification, single slide unit)

Special specification	Supplemental code	Size											
		10	12	15	20	25	30	35	45	55	65	85	100
Changed pitch of slide unit middle mounting holes ⁽¹⁾	/GE	–	×	○	○	○	○	○	○	○	○	–	–
Female threads for bellows ⁽²⁾	/JO	–	×	○	○	○	○	○	○	○	○	–	–
No end seal ⁽³⁾	/N	–	○	○	○	○	○	○	○	×	×	–	–
With C-Lube plate ⁽⁴⁾	/Q	–	○	○	○	○	○	○	○	○	○	–	–
Double end seals	/VO	–	○	○	○	○	○	○	○	○	○	–	–
Scrapers	/ZO	–	○	○	○	○	○	○	○	○	○	–	–

Notes ⁽¹⁾ Applicable to flange type (MX, MXG, MXH20, MXHG20, LRX, LRXG, LRXH20, LRXHG20).
⁽²⁾ Not applicable to stainless steel made products.
⁽³⁾ Not applicable to low profile flange type (MXN, MXNG, MXNL) and low profile block type (MXNS, MXNSG, MXNSL).
⁽⁴⁾ Applicable to LRX series.

Table 7.2 Application of special specifications (Interchangeable specification, single track rail)

Special specification	Supplemental code	Size											
		10	12	15	20	25	30	35	45	55	65	85	100
Specified rail mounting hole positions	/E	–	○	○	○	○	○	○	○	○	○	–	–
Caps for rail mounting holes	/F	–	○	○	○	○	○	○	○	○	○	–	–
Half pitch mounting holes for track rail	/HP	–	○	○	○	○	○	○	○	○	○	–	–
Female threads for bellows ⁽¹⁾	/J	–	×	○	○	○	○	○	○	○	○	–	–
Black chrome surface treatment	/LR	–	○	○	○	○	○	○	○	○	○	–	–
Without track rail mounting bolt	/MN	–	○	○	○	○	○	○	○	○	○	–	–
Butt-jointing track rails	/T	–	○	○	○	○	○	○	○	○	○	–	–

Note ⁽¹⁾ Not applicable to stainless steel made products.

Table 7.3 Application of special specifications (Interchangeable specification, assembled set)

Special specification	Supplemental code	Size												
		10	12	15	20	25	30	35	45	55	65	85	100	
Opposite reference surfaces arrangement	/D	–	○	○	○	○	○	○	○	○	○	–	–	
Specified rail mounting hole positions	/E	–	○	○	○	○	○	○	○	○	○	–	–	
Caps for rail mounting holes	/F	–	○	○	○	○	○	○	○	○	○	–	–	
Changed pitch of slide unit middle mounting holes ⁽¹⁾	/GE	–	×	○	○	○	○	○	○	○	○	–	–	
Half pitch mounting holes for track rail	/HP	–	○	○	○	○	○	○	○	○	○	–	–	
Female threads for bellows ⁽²⁾	/JO	–	×	○	○	○	○	○	○	○	○	–	–	
Black chrome surface treatment	/LO	–	○	○	○	○	○	○	○	○	○	–	–	
Fluorine black chrome surface treatment	/LFO	–	○	○	○	○	○	○	○	○	○	–	–	
With track rail mounting bolt ⁽³⁾	/MA	–	○	○	○	○	○	○	○	○	○	–	–	
Without track rail mounting bolt ⁽⁴⁾	/MN	–	○	○	○	○	○	○	○	○	○	–	–	
No end seal ⁽⁵⁾	/N	–	○	○	○	○	○	○	○	○	×	×	–	–
With C-Lube plate ⁽⁴⁾	/Q	–	○	○	○	○	○	○	○	○	○	○	–	–
Butt-jointing track rails	/T	–	○	○	○	○	○	○	○	○	○	○	–	–
Double end seals	/VO	–	○	○	○	○	○	○	○	○	○	○	–	–
Specified grease ⁽⁶⁾	/YO	–	○	○	○	○	○	○	○	○	○	○	–	–
Scrapers	/ZO	–	○	○	○	○	○	○	○	○	○	○	–	–

Notes ⁽¹⁾ Applicable to flange type (MX, MXG, MXH20, MXHG20, LRX, LRXG, LRXH20, LRXHG20).
⁽²⁾ Not applicable to stainless steel made products.
⁽³⁾ Applicable to MX series.
⁽⁴⁾ Applicable to LRX series.
⁽⁵⁾ Not applicable to low profile flange type (MXN, MXNG, MXNL) and low profile block type (MXNS, MXNSG, MXNSL).
⁽⁶⁾ MX series is applicable only to /YCG.

Table 7.4 Application of special specifications (Non-interchangeable specification)

Special specification	Supplemental code	Size											
		10	12	15	20	25	30	35	45	55	65	85	100
Butt-jointing track rails	/A	○	○	○	○	○	○	○	○	○	○	○	○
Opposite reference surfaces arrangement	/D	○	○	○	○	○	○	○	○	○	○	○	○
Specified rail mounting hole positions	/E	○	○	○	○	○	○	○	○	○	○	○	○
Caps for rail mounting holes	/F	×	○	○	○	○	○	○	○	○	○	○	○
Changed pitch of slide unit middle mounting holes ⁽¹⁾	/GE	×	×	○	○	○	○	○	○	○	○	×	○
Half pitch mounting holes for track rail	/HP	×	○	○	○	○	○	○	○	○	○	○	×
Inspection sheet	/I	○	○	○	○	○	○	○	○	○	○	○	○
Female threads for bellows	/JO	×	×	○	○	○	○	○	○	○	○	○	×
Black chrome surface treatment	/LO	×	○	○	○	○	○	○	○	○	○	×	×
Fluorine black chrome surface treatment	/LFO	×	○	○	○	○	○	○	○	○	○	×	×
With track rail mounting bolt ⁽²⁾	/MA	○	○	○	○	○	○	○	○	○	○	×	×
Without track rail mounting bolt ⁽³⁾	/MN	○	○	○	○	○	○	○	○	○	○	○	○
No end seal ⁽⁴⁾	/N	○	○	○	○	○	○	○	○	○	×	×	×
Rail cover plate for track rail ⁽³⁾	/PS	×	×	×	×	×	×	○	○	○	×	×	×
With C-Lube plate ⁽³⁾	/Q	○	○	○	○	○	○	○	○	○	○	○	×
C-Wiper ^{(2) (5)}	/RCO	×	×	×	○	○	○	○	○	○	○	×	×
Inner seal ⁽²⁾	/UR	×	×	×	○	○	○	○	○	○	○	×	×
Double end seals	/VO	×	○	○	○	○	○	○	○	○	○	○	○
A group of multiple assembled sets ⁽⁶⁾	/WO	○	○	○	○	○	○	○	○	○	○	○	×
Specified grease ⁽⁷⁾	/YO	○	○	○	○	○	○	○	○	○	○	○	○
Scrapers	/ZO	×	○	○	○	○	○	○	○	○	○	○	○

Notes ⁽¹⁾ Applicable to flange type (MX, MXG, MXH20, MXHG20, LRX, LRXG, LRXH20, LRXHG20).
⁽²⁾ Applicable to MX series.
⁽³⁾ Applicable to LRX series.
⁽⁴⁾ Not applicable to low profile flange type (MXN, MXNG, MXNL) and low profile block type (MXNS, MXNSG, MXNSL).
⁽⁵⁾ Since inner seal and scraper are mounted simultaneously, indication of "/UR" or "/Z" is not necessary.
⁽⁶⁾ LRX85, LRXG85, LRL85, LRLD85, LRLDG85, LRLDL85 are applicable only to High (H) and Precision (P).
⁽⁷⁾ MX series is applicable only to /YCG.

Table 10.2 Dimension of female threads for bellows (Supplemental code Single unit: /J Assembled set: /J /JJ)

Identification number		Slide unit							Track rail									
		a_1	a_2	b_1	b_2	b_3	b_4	$M_1 \times \text{depth}$	$L_1^{(1)}$	a_3	a_4	$M_2 \times \text{depth}$						
MXC 35	LRXC 35	6	16	30	20	60	M3 × 6	99	8	16	M4 × 8							
MX 35	LRX 35							131										
MXG 35	LRXG 35							159										
MXL 35	—			191														
MXDC 35	LRXDC 35			99														
MXD 35	LRXD 35			131														
MXDG 35	LRXDG 35	13	15	5	60	M3 × 6	159	8	16	M4 × 8								
MXDL 35	—						191											
MXS 35	—						131											
MXSG 35	—	7	21	35	23	74	M4 × 8	159	10	19	M5 × 10							
MXC 45	LRXC 45							123										
MX 45	LRX 45							163										
MXG 45	LRXG 45			203														
MXL 45	—			243														
MXDC 45	LRXDC 45			123														
MXD 45	LRXD 45	17	18	6	74	M4 × 8	163	10	19	M5 × 10								
MXDG 45	LRXDG 45						203											
MXDL 45	—						243											
MXS 45	—	7	27	40	26	88	M4 × 8	163	10	24	M5 × 10							
MXSG 45	—							203										
MXC 55	LRXC 55							145										
MX 55	LRX 55			193														
MXG 55	LRXG 55			247														
MXL 55	—			301														
MXDC 55	LRXDC 55	17	20	6	88	M4 × 8	145	10	24	M5 × 10								
MXD 55	LRXD 55						193											
MXDG 55	LRXDG 55						247											
MXDL 55	—	8.7	37	47.5	31	108	M5 × 10	301	14	28	M6 × 12							
MXS 55	—							193										
MXSG 55	—							247										
MXC 65	—			15	45			62.5				90	140	M6 × 10	191	14.5	38	M6 × 12
—	LRXC 65														192			
MX 65	—														255			
—	LRX 65	15	45	38	90	140	M6 × 10	256	14.5	38	M6 × 12							
MXG 65	—							319										
—	LRXG 65							320										
MXL 65	—	15	45	25.5	9	140	M6 × 10	391	14.5	38	M6 × 12							
MXDC 65	LRXDC 65							191										
MXD 65	—							192										
—	LRXD 65	15	45	25.5	9	140	M6 × 10	255	14.5	38	M6 × 12							
MXDG 65	—							256										
—	LRXDG 65							319										
MXDL 65	—	15	45	37.5	140	M6 × 10	M6 × 10	320	14.5	38	M6 × 12							
—	LRX 85							391										
—	LRXC 85							334										
—	LRXG 85	15	45	62.5	90	140	M6 × 10	406	14.5	38	M6 × 12							
—	LRXL 85							505										
—	LRXD 85							334										
—	LRXDG 85	15	45	38	90	140	M6 × 10	406	14.5	38	M6 × 12							
—	LRXDL 85							505										

Note (1) Dimensions of the specification that female threads for bellows are fitted to both ends of the slide unit are indicated.

Table 10.3 Dimension of female threads for bellows (Supplemental code Single unit: /J Assembled set: /J /JJ)

Identification number	Slide unit								Track rail			
	$a_1^{(1)}$	a_2	b_1	b_2	b_3	b_4	$M_1 \times \text{depth}$	$L_1^{(2)}$	H_3	a_3	a_4	$M_2 \times \text{depth}$
MXN 30	14.5	—	20	50	—	—	M3 × 6	128	0.8	7	14	M4 × 8
MXNG 30								149				
MXNL 30			177									
MXNS 30			128									
MXNSG 30			149									
MXNSL 30	177											
MXN 35	2	16	30	40	—	60	M3 × 6	131	—	8	16	M4 × 8
MXNG 35								159				
MXNL 35			191									
MXNS 35			131									
MXNSG 35			159									
MXNSL 35	191											
MXN 45	1	21	35	50	—	74	M4 × 8	163	—	10	19	M5 × 10
MXNG 45								203				
MXNL 45			243									
MXNS 45			163									
MXNSG 45			203									
MXNSL 45	243											
MXN 55	0	27	40	60	—	88	M4 × 8	193	—	10	24	M5 × 10
MXNG 55								247				
MXNL 55			301									
MXNS 55			193									
MXNSG 55			247									
MXNSL 55	301											

Notes (1) a_1 shows the dimension between mounting surface C and upper female thread.

(2) Dimensions of the specification that female threads for bellows are fitted to both ends of the slide unit are indicated.

Remark: The dimension of * is higher than the dimensions of assembly H. For details of dimensions, contact IKO.

Table 11.1 Dimension of slide unit with C-Lube plate (Supplemental code /Q)

Size: 10, 12, 15, 20, 25, 30

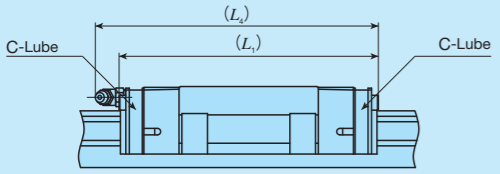

unit: mm

Identification number	L_1	L_4
LRXD 10...SL	44	—
LRXC 12	47	50
LRX 12	57	60
LRXG 12	68	71
LRXC 15	63	64
LRX 15	79	80
LRXG 15	95	96
LRXC 20	76	84
LRX 20	96	104
LRXG 20	116	124
LRXC 25	85	93
LRX 25	109	117
LRXG 25	124	132
LRXC 30	96	107
LRX 30	124	135
LRXG 30	145	156

Remarks 1. The dimensions of the slide unit with C-Lube at both ends are indicated.
2. A typical identification number is indicated, but is applied to all LRX series models of the same type.

Table 11.2 Dimension of slide unit with C-Lube plate (Supplemental code /Q)

Size: 35, 45, 55, 65, 85

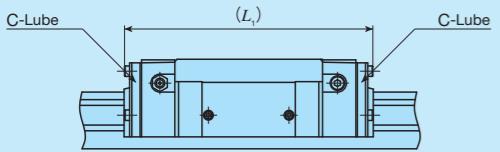

unit: mm

Identification number	L_1
LRXC 35	103
LRX 35	135
LRXG 35	163
LRXC 45	127
LRX 45	167
LRXG 45	207
LRXC 55	149
LRX 55	197
LRXG 55	251
LRXC 65	198
LRX 65	262
LRXG 65	326
LRX 85	341
LRXG 85	413
LRXL 85	512

Remarks 1. The dimensions of the slide unit with C-Lube at both ends are indicated.
2. A typical identification number is indicated, but is applied to all LRX series models of the same type.

Table 12.1 Dimension of slide unit with C-Wiper (Supplemental code Assembled set: /RC /RCC)

Size: 20, 25, 30

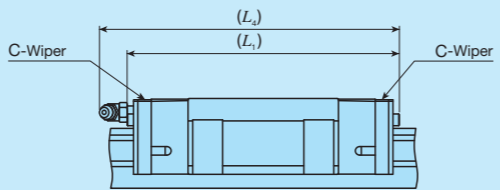

unit: mm

Identification number	L_1	L_4
MXC 20	80	90
MX 20	100	110
MXG 20	120	130
MXL 20	142	153
MXC 25	89	99
MX 25	113	123
MXG 25	128	138
MXL 25	152	162
MXC 30	100	113
MX 30	128	141
MXN 30	—	138
MXG 30	149	162
MXNG 30	—	159
MXL 30	—	190
MXNL 30	177	187

Remarks 1. The dimensions of the slide unit with C-Wiper at both ends are indicated.
2. A typical identification number is indicated, but is applied to all MX series models of the same size.

Table 12.2 Dimension of slide unit with C-Wiper (Supplemental code Assembled set: /RC /RCC)

Size: 35, 45, 55, 65

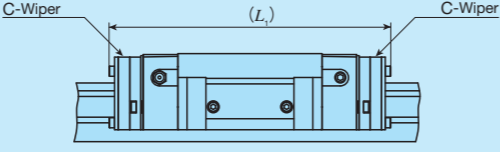

unit: mm

Identification number	L_1
MXC 35	123
MX 35	155
MXG 35	183
MXL 35	215
MXC 45	149
MX 45	189
MXG 45	229
MXL 45	269
MXC 55	172
MX 55	220
MXG 55	274
MXL 55	328
MXC 65	223
MX 65	287
MXG 65	351
MXL 65	423

Remarks 1. The dimensions of the slide unit with C-Wiper at both ends are indicated.
2. A typical identification number is indicated, but is applied to all MX series models of the same size.

Table 13.1 Dimension of slide unit with double end seals (Supplemental code Single unit: /V Assembled set: /V /VV)

Size: 12, 15, 20, 25, 30

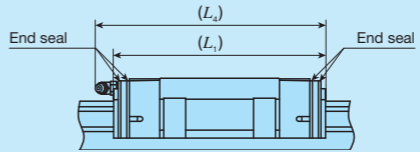

unit: mm

Identification number	L_1	L_4
MXC 12	—	49
—	LRXC 12	44
MX 12	—	58
—	LRX 12	54
MXG 12	—	70
—	LRXG 12	65
MXC 15	LRXC 15	58
MX 15	LRX 15	74
MXG 15	LRXG 15	90
MXC 20	LRXC 20	73
MX 20	LRX 20	93
MXG 20	LRXG 20	113
MXL 20	—	135
MXC 25	LRXC 25	83
MX 25	LRX 25	107
MXG 25	LRXG 25	122
MXL 25	—	146
MXC 30	LRXC 30	93
MX 30	LRX 30	121
MXN 30	—	—
MXG 30	LRXG 30	142
MXNG 30	—	—
MXL 30	—	170
MXNL 30	—	180

Remarks 1. The dimensions of the slide unit with double end seals at both ends are indicated.
2. A typical identification number is indicated, but is applied to all models of the same size.

Table 13.2 Dimension of slide unit with double end seals (Supplemental code Single unit: /V Assembled set: /V /VV)

Size: 35, 45, 55, 65, 85, 100

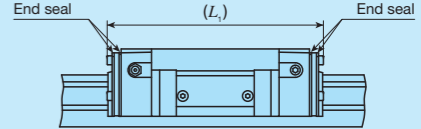

unit: mm

Identification number	L_1	
MXC 35	LRXC 35	101
MX 35	LRX 35	133
MXG 35	LRXG 35	161
MXL 35	—	193
MXC 45	LRXC 45	127
MX 45	LRX 45	167
MXG 45	LRXG 45	207
MXL 45	—	247
MXC 55	LRXC 55	149
MX 55	LRX 55	197
MXG 55	LRXG 55	251
MXL 55	—	305
MXC 65	—	192
—	LRXC 65	193
MX 65	—	256
—	LRX 65	257
MXG 65	—	320
—	LRXG 65	321
MXL 65	—	392
—	LRX 85	338
—	LRXG 85	410
—	LRXL 85	509
—	LRXG 100	376

Remarks 1. The dimensions of the slide unit with double end seals at both ends are indicated.
2. A typical identification number is indicated, but is applied to all models of the same size.

Table 14.1 Dimension of slide unit with scrapers
(Supplemental code Single unit: /Z
Assembled set: /Z /ZZ)

Size: 12, 15, 20, 25, 30

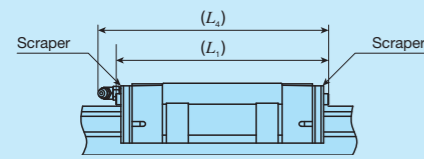

unit: mm

Identification number	L_1	L_2
MXC 12	—	50
—	LRXC 12	45
MX 12	—	60
—	LRX 12	56
MXG 12	—	71
—	LRXG 12	66
MXC 15	LRXC 15	60
MX 15	LRX 15	76
MXG 15	LRXG 15	92
MXC 20	LRXC 20	74
MX 20	LRX 20	94
MXG 20	LRXG 20	114
MXL 20	—	137
MXC 25	LRXC 25	85
MX 25	LRX 25	109
MXG 25	LRXG 25	124
MXL 25	—	148
MXC 30	LRXC 30	96
MX 30	LRX 30	124
MXN 30	—	132
MXG 30	LRXG 30	145
MXNG 30	—	153
MXL 30	—	173
MXNL 30	—	181

Remarks 1. The dimensions of the slide unit with scraper at both ends are indicated.
2. A typical identification number is indicated, but is applied to all models of the same size.

Table 14.2 Dimension of slide unit with scrapers
(Supplemental code Single unit: /Z
Assembled set: /Z /ZZ)

Size: 35, 45, 55, 65, 85, 100

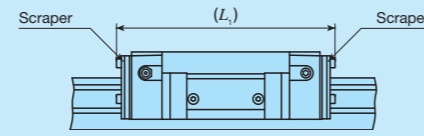

unit: mm

Identification number	L_1
MXC 35	LRXC 35
MX 35	LRX 35
MXG 35	LRXG 35
MXL 35	—
MXC 45	LRXC 45
MX 45	LRX 45
MXG 45	LRXG 45
MXL 45	—
MXC 55	LRXC 55
MX 55	LRX 55
MXG 55	LRXG 55
MXL 55	—
MXC 65	LRXC 65
MX 65	LRX 65
MXG 65	LRXG 65
MXL 65	—
—	LRX 85
—	LRXG 85
—	LRXL 85
—	LRXG 100

Remarks 1. The dimensions of the slide unit with scraper at both ends are indicated.
2. A typical identification number is indicated, but is applied to all models of the same size.

Lubrication

Lithium-soap base grease with extreme-pressure additive (Alvania EP grease 2 [SHOWA SHELL SEKIYU K. K.]) is pre-packed in MX series and LRX series. Additionally, MX series has C-Lube placed in the recirculation part of cylindrical roller, so that the interval for reapplying lubricant can be extended and maintenance works such as grease job can be reduced significantly.

MX series and LRX series have grease nipple or oil hole as indicated in Table 15. Supply nozzles fit to each shapes of grease nipple and dedicated supplying equipment (miniature greasers) fit to oil holes are also available. For order of these parts for lubrication, see Table 13 and Table 14.1 on Page III-23, and Table 15 on page III-24.

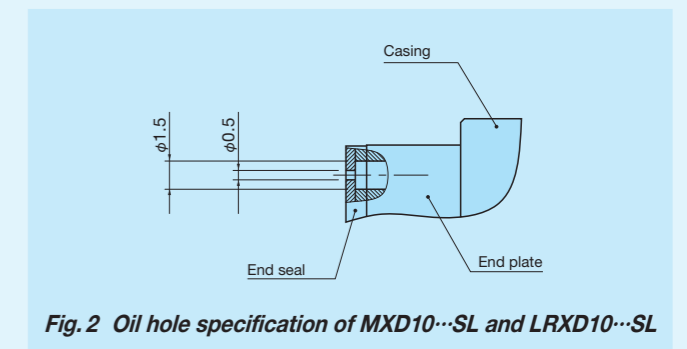

Fig. 2 Oil hole specification of MXD10...SL and LRXD10...SL

Table 15 Parts for lubrication

Size	Grease nipple type ⁽¹⁾	Applicable supply nozzle type	Bolt size of female threads for piping
10	Oil hole	Miniature greaser	—
12	A-M3	A-5120V A-5240V	—
15 ⁽²⁾	A-M4	B-5120V B-5240V	M4
20 ⁽²⁾	B-M4	A-8120V	
25 ⁽²⁾		B-8120V	
30 ^{(3) (4)}	B-M6	Grease gun available on the market	M6
35 ⁽⁵⁾	JIS1 type		PT1/8
45 ⁽⁶⁾	JIS2 type		
55			
65			
85	A-PT1/4		PT1/4
100			

Notes ⁽¹⁾ For grease nipple specification, see Table 14.1 and Table 14.2 in page III-23.

⁽²⁾ The grease nipple when female threads for bellows (supplemental code "/J") is specified is A-M3.

⁽³⁾ The grease nipple when female threads for bellows (supplemental code "/J") is specified is A-M4.

⁽⁴⁾ The grease nipple for MXN30 is B-M4. The grease nipple when female threads for bellows (supplemental code "/J") is specified is A-M4.

⁽⁵⁾ The size of the grease nipple mounting thread hole for MXN35 in the slide unit travelling direction is smaller than that of the crosswise direction. When the grease nipple is mounted along the travelling direction, contact IKO.

⁽⁶⁾ The grease nipple for MXN45 is JIS type1.

Remark: Stainless steel grease nipple is also available. If needed, please contact IKO.

Dust Protection

The slide units of MX series and LRX series are equipped with end seals and under seals as standard for dust protection. However, if large amount of contaminant or dust are floating, or if large particles of foreign substances such as chips or sand may adhere to the track rail, it is recommended to cover the whole unit with bellows or telescope type shield, etc. MX series and LRX series are provided with specific bellows. The bellows are easy to mount and provide excellent dust protection. If needed, please refer to III-26 for ordering. Also the rail cover sheet to cover the mounting hole of track rail (Fig. 3) and track rail mounting from bottom with no mounting hole on the upper surface (Fig. 4) are available. If needed, please contact IKO.

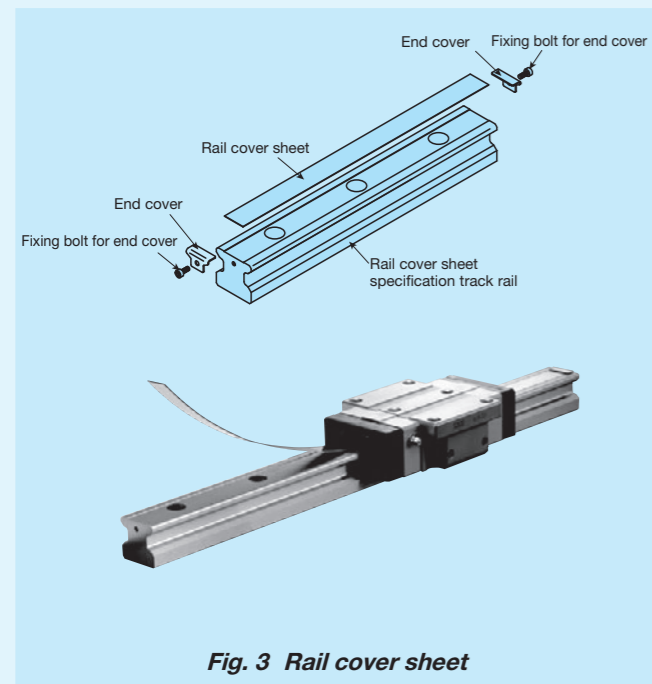

Fig. 3 Rail cover sheet

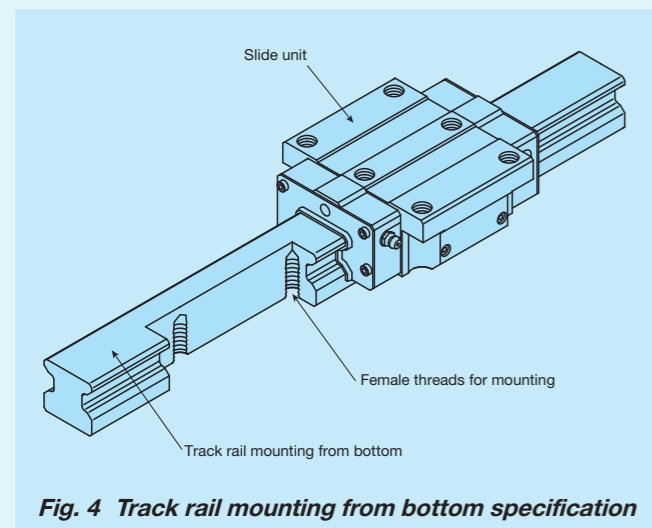

Fig. 4 Track rail mounting from bottom specification

Precaution for Use

1 Mounting surface, reference mounting surface and typical mounting structure

When mounting the MX series and LRX series, properly align the reference mounting surfaces B and D of the track rail and slide unit with the reference mounting surface of the table and bed and fix them. (See Fig. 5.)

The reference mounting surfaces B and D and mounting surfaces A and C are precisely ground. Machining the mounting surface of the table and bed, such as machine or device, to high accuracy and mounting them properly will ensure stable linear motion with high accuracy.

Reference mounting surface of the slide unit is the opposite side of the IKO mark. The track rail reference mounting surface is identified by locating the IKO mark on the top surface of the track rail. It is the side surface above the mark (in the direction of the arrow). (See Fig. 6.)

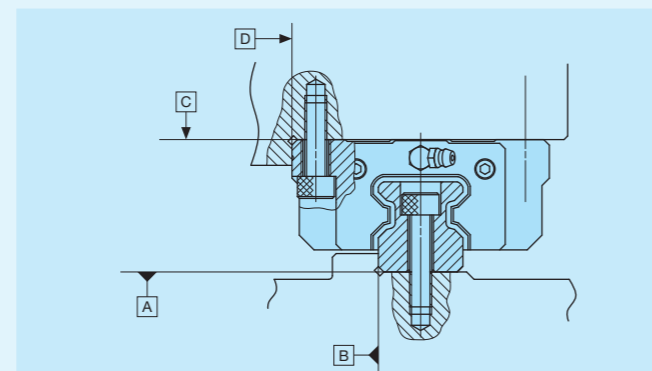

Fig. 5 Reference mounting surface and typical mounting structure

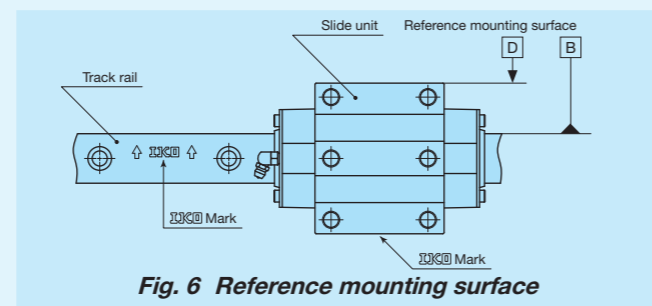

Fig. 6 Reference mounting surface

2 Fixing the slide unit

Slide unit is also provided with mounting holes in the middle of width direction (see Fig. 7) and some products have the arrangement to receive the applied load in a good balance. When designing machines or equipment, consider the arrangement so that the mounting holes in the middle of slide unit can also be used to fix the units, to use the highest performance out of the product. To fix the slide unit of compact block type or low profile block type, we recommend to secure the fixing thread depth of Table 16.1 and Table 16.2. Also, with the low profile flange type and low profile block type, make sure that the fixing thread depth for the mounting screw in the middle of slide unit width direction should be less than the maximum fixing thread depth of the dimension table.

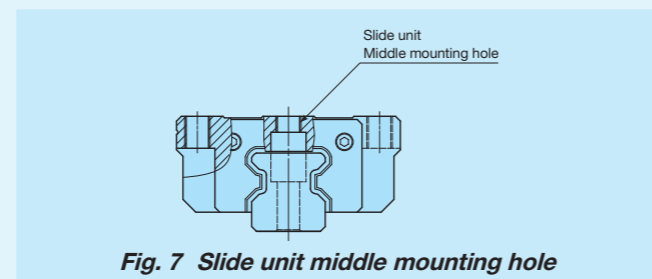

Fig. 7 Slide unit middle mounting hole

Table 16.1 Fixing thread depth for slide unit mounting hole of compact block type unit: mm

Identification number	Recommended minimum fixing thread depth
MXS 15	4.5
MXS 20	5.5
MXS 25	7
MXS 30	9

Remark: A typical identification number is indicated, but is applied to all compact block types of the same size.

Table 16.2 Fixing thread depth for slide unit mounting hole of low profile block type unit: mm

Identification number	Recommended minimum fixing thread depth
MXNS 30	8
MXNS 35	8.5
MXNS 45	10.5
MXNS 55	14

Remark: A typical identification number is indicated, but is applied to all low profile block types of the same size.

3 Shoulder height and corner radius of the reference mounting surface

For the opposite corner of the mating reference mounting, it is recommended to have relieved fillet as indicated in Fig. 8, but you may also use it with providing corner radius R as shown in Table 17. Recommended value for the shoulder height and corner radius on the mating side is indicated in Table 17.

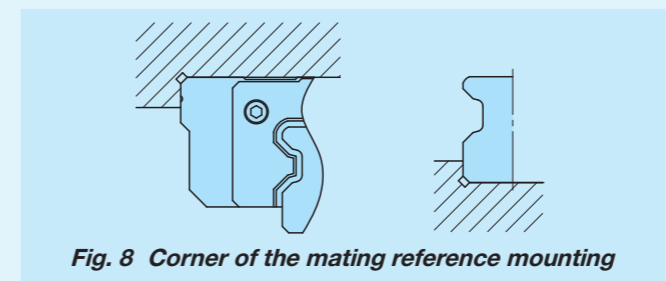

Fig. 8 Corner of the mating reference mounting

Table 17 Shoulder height and corner radius of the reference mounting surface unit: mm

Size	Shoulder height of slide unit mounting part h_1	Shoulder height of track rail mounting part h_2	Corner radius R (Maximum)
10	4	1	0.3
12	4	2	0.5
15	4	3	0.5
20	5	4	0.5
25	6	5	1
30	8	5.5	1
35	8	5.5	1
45	8	7	1.5
55	10	8	1.5
65	10	10	1.5
85	14	14	2.5 (Slide unit) 1.5 (Track rail)
100	14	13	2.5

4 Tightening torque for fixing screw

Typical tightening torque for mounting of the MX series and LRX series to the steel mating member material is indicated in Table 18. When vibration and shock of the machine or device are large, fluctuating load is large, or moment load is applied, fix it by using the torque 1.2 to 1.5 times larger than the value indicated in the table as necessary. If the mating member material is cast iron or aluminum alloy, reduce the tightening torque depending on the strength characteristics of the mating member material.

Table 18 Tightening torque for fixing screw

Bolt size	Tightening torque N · m		Stainless steel-made screw
	High carbon steel-made screw	Size 85 and 100	
M 2.6×0.45	—	—	0.70
M 3 ×0.5	1.8	—	1.1
M 4 ×0.7	4.1	—	2.5
M 5 ×0.8	8.0	—	5.0
M 6 ×1	13.6	—	8.5
M 8 ×1.25	32.7	—	20.4
M10 ×1.5	63.9	—	—
M12 ×1.75	110	—	—
M14 ×2	175	—	—
M16 ×2	268	—	—
M20 ×2.5	522	—	—
M24 ×3	—	749	—
M30 ×3.5	—	1 490	—

Remarks 1. The tightening torque is calculated based on strength division 12.9 for product size 12 to 65, strength division 10.9 for product sizes 85 and 100, and property division A2-70 for stainless steel bolts.

2. It is recommended that the tightening torque of slide unit middle mounting holes for size 15, 20, 25, 30, 35 of flange type (MXC, MX, MXG, MXL, LRXC, LRX, LRXG) is to be 70 to 80% of the values in the table.

5 Remarks

- As LRX(D)(G,L)85 and LRXG100 are heavyweight products, we recommend the use of eyebolts for transport and assembly. For eyebolt mounting, use the slide unit mounting holes and the track rail female threads for eyebolts (Fig. 9). For the LRXG100 track rail, also use the LRXG100 track rail dedicated eyebolt adapter (Fig. 10).
- LRX(D)(G,L)85 slide unit eyebolts (JIS B1168 M20) and LRX85 track rail dedicated eyebolts (Fig. 11) are not appended. If needed, please contact IKO.

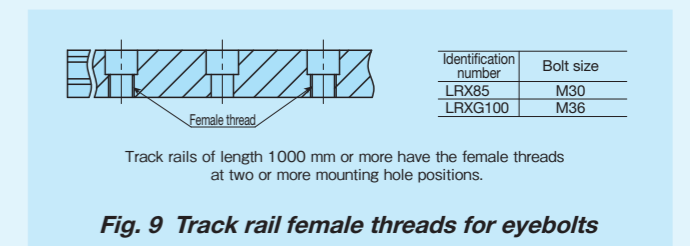

Fig. 9 Track rail female threads for eyebolts

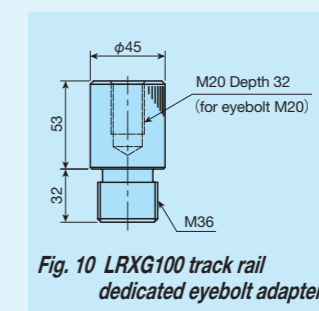

Fig. 10 LRXG100 track rail dedicated eyebolt adapter

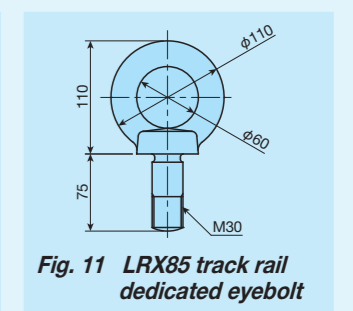
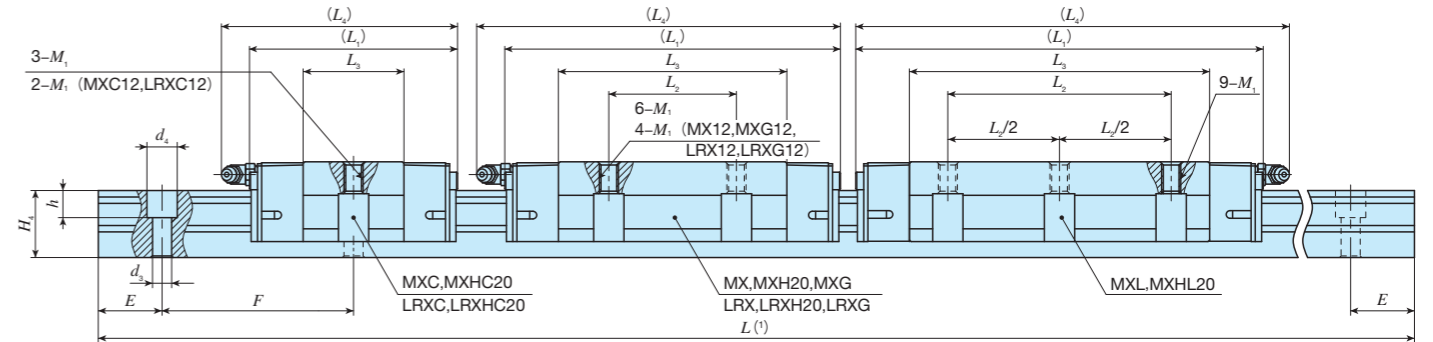
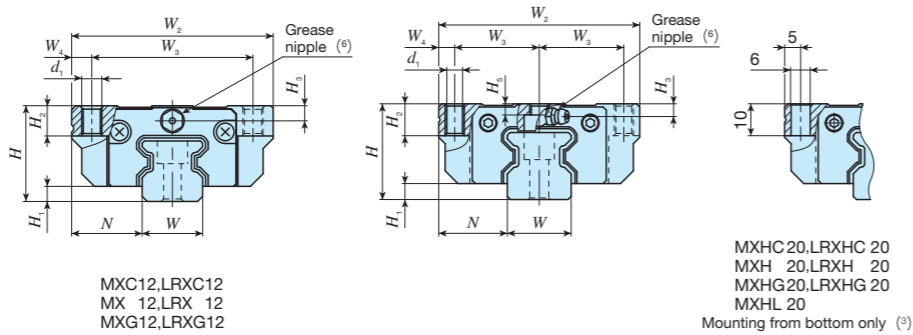

Fig. 11 LRX85 track rail dedicated eyebolt

IKO C-Lube Linear Roller Way Super MX

Flange type mounting from top / bottom

Shape	MX • LRX				
Size	12	15	20	25	30
	35	45	55	65	100



Identification number	Interchangeable	Mass (Ref.)		Dimensions of assembly mm		Dimensions of slide unit mm										Dimensions of track rail mm						Appended mounting bolt for track rail (4)	Basic dynamic load rating (5)	Basic static load rating (5)	Static moment rating (5)										
		Slide unit kg	Track rail kg/m	H	H ₁	N	W ₂	W ₃	W ₄	L ₁	L ₂	L ₃	L ₄	d ₁	M ₁	H ₂	H ₃	H ₅	W	H ₄	d ₃				d ₄	h	E	F	Bolt size × ℓ	C	C ₀	T ₀	T _x	T _y	
MXC 12	LRXC 12	0.058								40	—	15.8	44																		4 250	6 500	49.4	18.6	18.6
MX 12	LRX 12	0.092	0.92	19	3	14	40	32	4	50	—	25.4	53	3.4	M4	6	3	—	12	12	3.5	6	4.5	20	40	M3×12	6 120	10 400	79.1	45.8	45.8				
MXG 12	LRXG 12	0.13								47	15	25.3	50																5 890		78.7	45.2	45.2		
MXC 15	LRXC 15	0.13								61	—	36.6	64																8 120	15 000	114	92.7	92.7		
MX 15	LRX 15	0.20	1.65	24	4	16	47	19	4.5	58	30	35.8	61	4.4	M5	7	3.5	3	15	16.5	4.5	8	6	30	60	M4×16	7 710	14 600	111	88.6	88.6				
MXG 15	LRXG 15	0.28								84	—	56	87																14 900	28 000	263	262	262		
MXC 20(2)	LRXC 20(2)	0.29								66	—	31.6	74																16 100	26 400	341	150	150		
MX 20(2)	LRX 20(2)	0.44								86	—	51.6	94	(2)	M6(2)														23 400	42 700	550	379	379		
MXG 20(2)	LRXG 20(2)	0.61								106	40	71.6	114																30 100	58 900	760	713	713		
MXL 20(2)	—	0.80	2.73	30	5	21.5	63	26.5	5	128	70	94.1	137			10	4	3.5	20	21	6	9.5	8.5	30	60	M5×20	37 200	77 200	996	1 210	1 210				
MXHC 20(3)	LRXHC 20(3)	0.29								66	—	31.6	74																16 100	26 400	341	150	150		
MXH 20(3)	LRXH 20(3)	0.44								86	—	51.6	94																23 400	42 700	550	379	379		
MXHG 20(3)	LRXHG 20(3)	0.61								106	40	71.6	114																30 100	58 900	760	713	713		
MXHL 20(3)	—	0.80								128	70	94.1	137																37 200	77 200	996	1 210	1 210		

Notes (1) Track rail lengths L are shown in Table 2.1 on page II - 175 and Table 2.3 on page II - 176 .
 (2) The mounting bolt can be mounted only in downward direction.
 (3) The mounting bolt can be mounted only in upward direction.
 (4) The appended track rail mounting bolts are hexagon socket head bolts equivalent to JIS B 1176. In an assembled set of MX series, track rail mounting bolts are not appended.
 (5) The direction of basic dynamic load rating (C), basic static load rating (C₀), and static moment rating (T₀, T_x, T_y) are shown in the sketches below. The upper values of T_x and T_y are for one slide unit and the lower values are for two slide units in close contact.
 (6) The shapes of grease nipple vary by size. The specifications are shown in Table 15 on page II - 188.
 Remark: A grease nipple mounting thread hole is provided on the right and left end plates respectively.

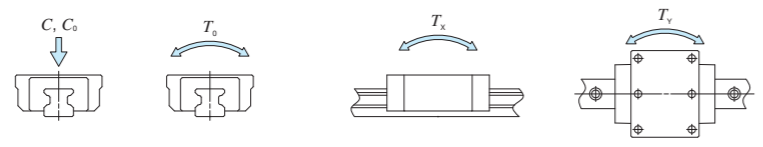

Example of identification number of assembled set

Model code Dimensions Part code Preload symbol Classification symbol Interchangeable code Supplemental code

MX **G** **15** **C2** **R360** **T1** **P** **/F**

① Model
 MX Flange type mounting from top / bottom
 LRX Flange type mounting from bottom

② Length of slide unit
 C Short
 No symbol Standard
 G Long
 L Extra long

③ Size
 12, 15, 20

④ Number of slide unit (2)

⑤ Length of track rail (360 mm)

⑥ Preload amount
 No symbol Standard
 T1 Light preload
 T2 Medium preload
 T3 Heavy preload

⑦ Accuracy class
 H High
 P Precision
 SP Super precision
 UP Ultra precision

⑧ Interchangeable
 No symbol Non-interchangeable specification
 S1 S1 specification
 S2 S2 specification

⑨ Special specification
 A, D, E, F, GE, HP, I, J, L
 LF, MA, MN, N, Q, RC, T
 UR, V, W, Y, Z

IKO C-Lube Linear Roller Way Super MX

Flange type mounting from top / bottom

Shape	MX • LRX				
Size	12	15	20	25	30
	35	45	55	65	85

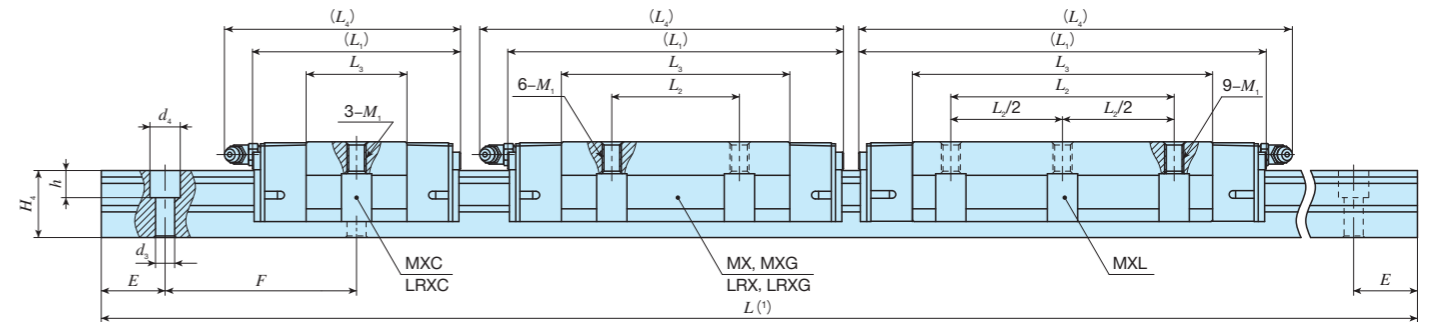
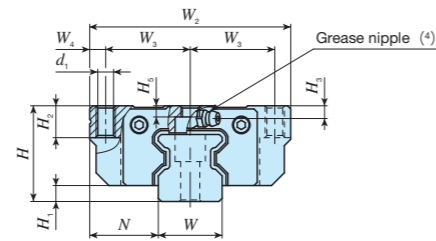

Identification number	Interchangeable	Mass (Ref.)		Dimensions of assembly mm				Dimensions of slide unit mm								Dimensions of track rail mm						Appended mounting bolt for track rail (2)	Basic dynamic load rating (3)	Basic static load rating (3)	Static moment rating (3)							
		Slide unit kg	Track rail kg/m	H	H ₁	N	W ₂	W ₃	W ₄	L ₁	L ₂	L ₃	L ₄	d ₁	M ₁	H ₂	H ₃	H ₅	W	H ₄	d ₃				d ₄	h	E	F	Bolt size × ℓ	C	C ₀	T ₀
MXC 25	LRXC 25	○	0.44	3.59	36	6	23.5	70	28.5	6.5	74	—	36	83	7	M 8	10	5	5	23	24.5	7	11	9	30	60	M6×25	21 600	33 800	500	213	213
MX 25	LRX 25	○	0.67								98	60	107	45														573	573			
MXG 25	LRXG 25	○	0.84								113	75	122	885														885				
MXL 25	—	—	1.08								137	70	99	146														1 530	1 530			
MXC 30	LRXC 30	○	0.78	5.01	42	6.5	31	90	36	9	85	—	42.4	95	8.5	M10	10	6.5	5.5	28	28	9	14	12	40	80	M8×28	29 200	44 600	808	329	329
MX 30	LRX 30	○	1.20								113	70.4	123	52														883	883			
MXG 30	LRXG 30	○	1.58								134	91.4	144	1 470														1 470				
MXL 30	—	—	2.03								162	80	119.4	172														1 530	1 530			

Notes (1) Track rail lengths L are shown in Table 2.1 on page II-175 and Table 2.3 on page II-176.
 (2) The appended track rail mounting bolts are hexagon socket head bolts equivalent to JIS B 1176. In an assembled set of MX series, track rail mounting bolts are not appended.
 (3) The direction of basic dynamic load rating (C), basic static load rating (C_0), and static moment rating (T_0 , T_x , T_y) are shown in the sketches below. The upper values of T_x and T_y are for one slide unit and the lower values are for two slide units in close contact.
 (4) The shapes of grease nipple vary by size. The specifications are shown in Table 15 on page II-188.
 Remark: A grease nipple mounting thread hole is provided on the right and left end plates respectively.

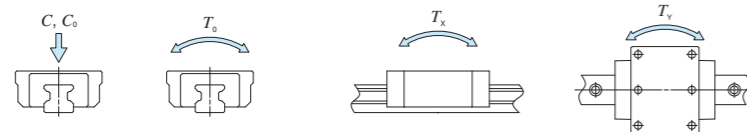

Example of identification number of assembled set

Model code Dimensions Part code Preload symbol Classification symbol Interchangeable code Supplemental code

MX G 25 C2 R840 T1 P /F

① ② ③ ④ ⑤ ⑥ ⑦ ⑧ ⑨

① Model MX Flange type mounting from top / bottom LRX	② Length of slide unit C Short No symbol Standard G Long L Extra long	③ Size 25, 30	④ Number of slide unit (2)	⑤ Length of track rail (840 mm)	⑥ Preload amount No symbol Standard T1 Light preload T2 Medium preload T3 Heavy preload	⑦ Accuracy class H High P Precision SP Super precision UP Ultra precision	⑧ Interchangeable No symbol Non-interchangeable specification S1 S1 specification S2 S2 specification	⑨ Special specification A, D, E, F, GE, HP, I, J, L LF, MA, MN, N, Q, RC, T UR, V, W, Y, Z
---	---	------------------	----------------------------	---------------------------------	---	---	--	---

IKO C-Lube Linear Roller Way Super MX

Flange type mounting from top / bottom

Shape	MX • LRX				
Size	12	15	20	25	30
	35	45	55	65	100

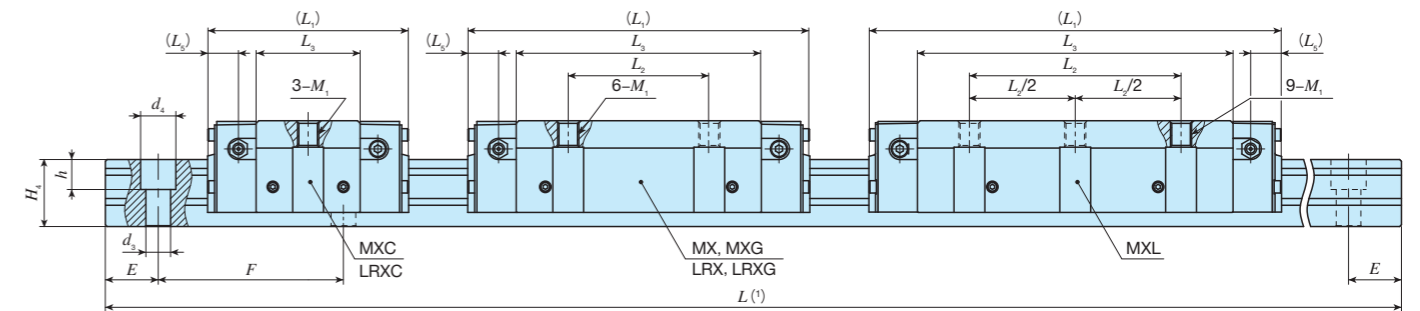
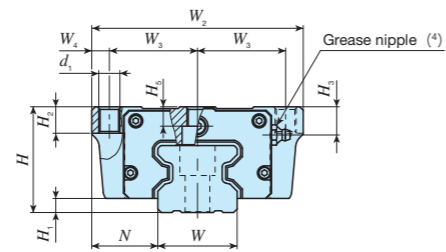

Identification number	Interchangeable	Mass (Ref.)		Dimensions of assembly mm			Dimensions of slide unit mm							Dimensions of track rail mm						Appended mounting bolt for track rail (2)	Basic dynamic load rating (3)	Basic static load rating (3)	Static moment rating (3)								
		Slide unit kg	Track rail kg/m	H	H ₁	N	W ₂	W ₃	W ₄	L ₁	L ₂	L ₃	L ₅	d ₁	M ₁	H ₂	H ₃	H ₅	W				H ₄	d ₃	d ₄	h	E	F	Bolt size × ℓ	C	C ₀
MXC 35	○	1.13	6.88	48	6.5	33	100	41	9	92	—	46.6	12.7	8.5	M10	13	13	7	34	32	9	14	12	40	80	M 8×35	39 500	60 000	1 300	506	506
LRXC 35	○	12.5								12.7	12.5	12.7	1360														1360				
MX 35	○	1.76								124	62	78.6	8470														8470				
LRX 35	○	12.5								12.7	12.5	12.7	13800														13800				
MXG 35	○	2.41								152	106.6	12.7	2440														2440				
LRXG 35	○	12.5	12.7	12.5	12.7	13800	13800																								
MXL 35	—	3.00	184	100	138.6	12.7	15100	15100																							
MXC 45	○	2.11	10.8	60	8	37.5	120	50	10	114	—	59	17.5	10.5	M12	15	16	11	45	38	14	20	17	52.5	105	M12×40	64 100	95 600	2 660	1 010	1 010
LRXC 45	○	12.5								12.7	12.5	12.7															16800	16800			
MX 45	○	3.26								154	80	99															2700	2700			
LRX 45	○	12.5								12.7	12.5	12.7															16800	16800			
MXG 45	○	4.60								194	139	17.5															5220	5220			
LRXG 45	○	12.5	12.7	12.5	12.7	29000	29000																								
MXL 45	—	5.66	234	120	179	17.5	8560	8560																							

Notes (1) Track rail lengths L are shown in Table 2.1 on page II-175 and Table 2.3 on page II-176.
 (2) The appended track rail mounting bolts are hexagon socket head bolts equivalent to JIS B 1176. In an assembled set of MX series, track rail mounting bolts are not appended.
 (3) The direction of basic dynamic load rating (C), basic static load rating (C_0), and static moment rating (T_0 , T_x , T_y) are shown in the sketches below. The upper values of T_x and T_y are for one slide unit and the lower values are for two slide units in close contact.
 (4) The shapes of grease nipple vary by size. The specifications are shown in Table 15 on page II-188.
 Remark: Three grease nipple mounting thread holes are provided on the right and left end plates respectively.

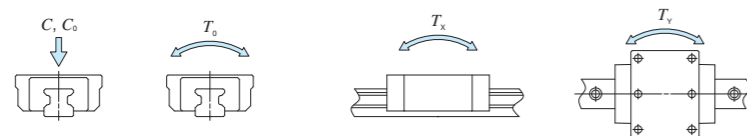

Example of identification number of assembled set

Model code Dimensions Part code Preload symbol Classification symbol Interchangeable code Supplemental code

MX G 35 C2 R1200 T2 P /F

① ② ③ ④ ⑤ ⑥ ⑦ ⑧ ⑨

① Model MX Flange type mounting from top / bottom LRX	② Length of slide unit C Short No symbol Standard G Long L Extra long	③ Size 35, 45	④ Number of slide unit (2)	⑤ Length of track rail (1,200 mm)	⑥ Preload amount No symbol Standard T1 Light preload T2 Medium preload T3 Heavy preload	⑦ Accuracy class H High P Precision SP Super precision UP Ultra precision	⑧ Interchangeable No symbol Non-interchangeable specification S1 S1 specification S2 S2 specification	⑨ Special specification A, D, E, F, GE, HP, I, J, L LF, MA, MN, N, PS, Q RC, T, UR, V, W, Y, Z
---	---	------------------	----------------------------	-----------------------------------	---	---	--	---

IKO C-Lube Linear Roller Way Super MX

Flange type mounting from top / bottom

Shape	MX • LRX				
Size	12	15	20	25	30
	35	45	55	65	85

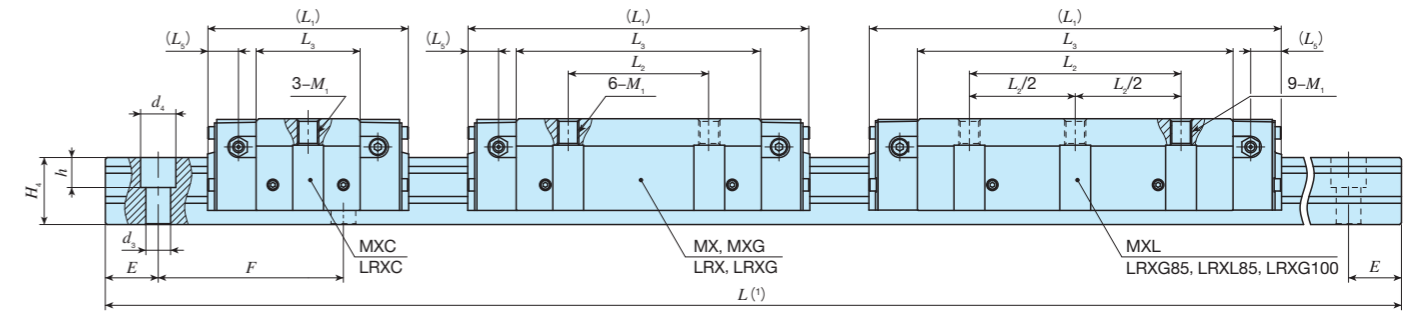
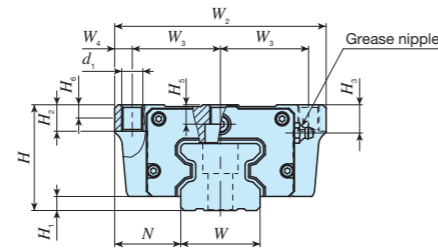

Identification number	Interchangeable	Mass (Ref.)		Dimensions of assembly mm											Dimensions of slide unit mm											Dimensions of track rail mm						Appended mounting bolt for track rail (2)	Basic dynamic load rating (3)	Basic static load rating (3)	Static moment rating (3)		
		Slide unit kg	Track rail kg/m	H	H1	N	W2	W3	W4	L1	L2	L3	L5	d1	M1	H2	H3	H5	H6	W	H4	d3	d4	h	E	F	C N	C0 N	T0 N·m	Tx N·m	Ty N·m						
MXC 55	LRXC 55	○	3.49	14.1	70	9	43.5	140	58	12	136	—	72	20	12.5	M14	17	16	14	—	53	43	16	23	20	60	120	M14×45	99 700	149 000	4 830	1 880	1 880				
MX 55	LRX 55	○	5.42								184	—	120																5 040	5 040							
MXG 55	LRXG 55	○	7.93								238	—	174																10 400	10 400							
MXL 55	—	—	10.1								292	150	228																17 700	17 700							
MXC 65	LRXC 65	○	7.18	22.6	90	12	53.5	170	71	14	180	—	95	26.3	14.5	M16	23	18	18.5	—	63	56	18	26	22	75	150	M16×60	174 000	249 000	9 790	4 200	4 200				
MX 65	LRX 65	○	11.5								181	—	26.6	32 000															32 000								
MXG 65	LRXG 65	○	16.0								244	—	26.3	4 200															4 200								
MXL 65	—	—	20.8								245	110	26.6	11 300															11 300								
—	LRX 85	—	25.4	36.7	110	16	65	215	92.5	15	323	140	232	27.5	17.8	M20	35	22	25.5	20	85	67	26.5	39	30	90	180	M24×70	440 000	753 000	38 900	29 500	29 500				
—	LRXG 85	—	32.7								395	200	304																163 000	163 000							
—	LRXL 85	—	44.0								494	280	403																50 000	50 000							
—	LRXG 100*	—	43.0								43.2	120	15																75	250	110	15	362	200	262	29.7	17.8

Notes (1) Track rail lengths L are shown in Table 2.1 on page II-175 and Table 2.3 on page II-176.
 (2) The appended track rail mounting bolts are hexagon socket head bolts equivalent to JIS B 1176. In an assembled set of MX series, track rail mounting bolts are not appended.
 (3) The direction of basic dynamic load rating (C), basic static load rating (C_0), and static moment rating (T_0 , T_x , T_y) are shown in the sketches below. The upper values of T_x and T_y are for one slide unit and the lower values are for two slide units in close contact.

Remarks 1. The specifications of grease nipple are shown in Table 15 on page II-188.
 2. Three grease nipple mounting thread holes are provided on the right and left end plates respectively.
 3. The identification numbers with * are our semi-standard items.

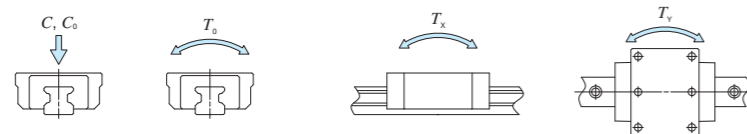

Example of identification number of assembled set

Model code Dimensions Part code Preload symbol Classification symbol Interchangeable code Supplemental code

MX G 55 C2 R3000 T2 P /F

① ② ③ ④ ⑤ ⑥ ⑦ ⑧ ⑨

① Model	MX Flange type mounting from top / bottom	③ Size	55, 65, 85, 100	⑥ Preload amount	No symbol Standard T1 Light preload T2 Medium preload T3 Heavy preload	⑧ Interchangeable	No symbol Non-interchangeable specification S1 S1 specification S2 S2 specification
② Length of slide unit	C Short No symbol Standard G Long L Extra long	④ Number of slide unit (2)		⑦ Accuracy class	H High P Precision SP Super precision UP Ultra precision	⑨ Special specification	A, D, E, F, GE, HP, I, J, L LF, MA, MN, PS, Q, RC T, UR, V, W, Y, Z
⑤ Length of track rail (3,000 mm)							

IKO C-Lube Linear Roller Way Super MX

Block type mounting from top

Shape	MXD • LRXD					
Size	10	12	15	20	25	30
	35	45	55	65	85	

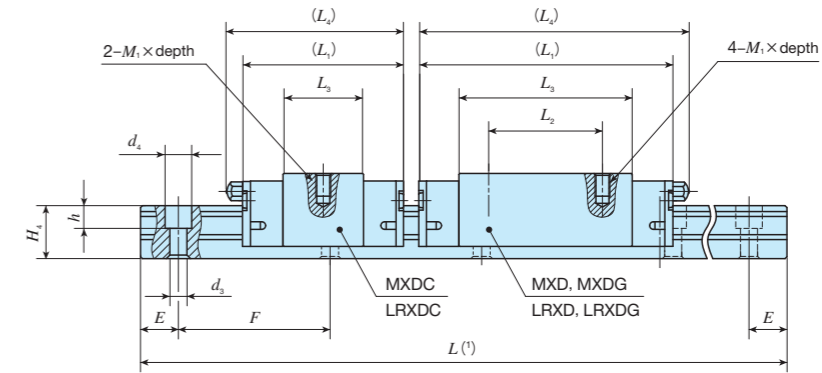
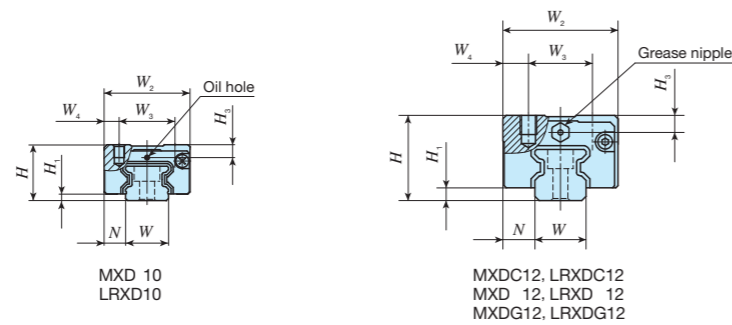

Identification number	Interchangeable	Mass (Ref.)		Dimensions of assembly mm			Dimensions of slide unit mm							Dimensions of track rail mm						Appended mounting bolt for track rail (2)	Basic dynamic load rating (3)	Basic static load rating (3)	Static moment rating (3)					
		Slide unit kg	Track rail kg/m	H	H1	N	W2	W3	W4	L1	L2	L3	L4	M1 x depth	H3	W	H4	d3	d4				h	E	F	Bolt size x l	C N	C0 N
MXD 10...SL	—	0.028	0.48	13	1.5	5	20	13	3.5	36	12	20.8	—	M2.6 x 3	3	10	8	3.5	6	3.5	12.5	25	M3 x 10	3 200	5 880	37.9	20.9	20.9
LRXD 10...SL	—																										147	147
MXDC 12	○	0.045	0.92	20	3	7.5	27	15	6	40	—	15.8	44	M4 x 4.5	4	12	12	3.5	6	4.5	20	40	M3 x 12	4 250	6 500	49.4	18.6	18.6
LRXDC 12	○																										196	196
—	○	0.072	0.92	20	3	7.5	27	15	6	37	—	14.8	40	M4 x 4.5	4	12	12	3.5	6	4.5	20	40	M3 x 12	3 900	6 090	46.3	16.3	16.3
LRXDC 12...SL	○																										170	170
MXD 12	○	0.072	0.92	20	3	7.5	27	15	6	50	—	25.4	53	M4 x 4.5	4	12	12	3.5	6	4.5	20	40	M3 x 12	6 120	10 400	79.1	45.8	45.8
LRXD 12	○																										371	371
MXD 12...SL	○	0.072	0.92	20	3	7.5	27	15	6	47	15	25.3	50	M4 x 4.5	4	12	12	3.5	6	4.5	20	40	M3 x 12	5 890	10 400	78.7	45.2	45.2
LRXD 12...SL	○																										343	343
MXDG 12	○	0.097	0.92	20	3	7.5	27	15	6	50	15	25.4	53	M4 x 4.5	4	12	12	3.5	6	4.5	20	40	M3 x 12	6 120	15 000	114	45.8	45.8
LRXD 12...SL	○																										371	371
—	○	0.097	0.92	20	3	7.5	27	15	6	61	—	36.6	64	M4 x 4.5	4	12	12	3.5	6	4.5	20	40	M3 x 12	8 120	15 000	114	92.7	92.7
LRXDG 12	○																										628	628
—	○	0.097	0.92	20	3	7.5	27	15	6	58	—	35.8	61	M4 x 4.5	4	12	12	3.5	6	4.5	20	40	M3 x 12	7 710	14 600	111	88.6	88.6
LRXDG 12...SL	○																										581	581

Notes (1) Track rail lengths L are shown in Tables 2.1 and 2.2 on page II-175 and Tables 2.3 and 2.4 on page II-176.
 (2) The appended track rail mounting bolts are hexagon socket head bolts equivalent to JIS B 1176. For stainless steel model, stainless steel bolts are appended.
 In an assembled set of MX series, track rail mounting bolts are not appended.
 (3) The direction of basic dynamic load rating (C), basic static load rating (C_0), and static moment rating (T_0 , T_x , T_y) are shown in the sketches below. The upper values of T_x and T_y are for one slide unit and the lower values are for two slide units in close contact.
 Remarks 1. The specification of oil hole is shown in Fig. 2 on page II-188.
 2. The specifications of grease nipple are shown in Table 15 on page II-188.
 3. For size 12 series, a grease nipple mounting thread hole is provided on the right and left end plates respectively.

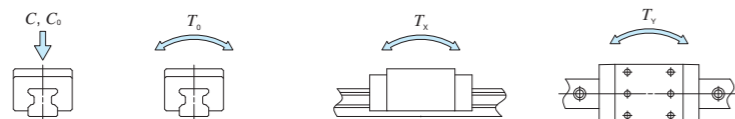

Example of identification number of assembled set

Model code	Dimensions	Part code	Material code	Preload symbol	Classification symbol	Interchangeable code	Supplemental code
MXD	G	12	C2	R560	T1	P	/F
①	②	③	④	⑤	⑥	⑦	⑧

① Model MXD LRXD Block type mounting from top	④ Number of slide unit (2)	⑦ Preload amount No symbol Standard T1 Light preload T2 Medium preload T3 Heavy preload	⑩ Interchangeable No symbol Non-interchangeable specification S1 S1 specification S2 S2 specification
② Length of slide unit C Short No symbol Standard G Long	⑤ Length of track rail (560 mm)	⑧ Accuracy class H High P Precision SP Super precision UP Ultra precision	⑪ Special specification A, D, E, F, HP, I, L, LF MA, MN, N, Q, T, V, W Y, Z
③ Size 10, 12	⑥ Material type No symbol High carbon steel made SL Stainless steel made		

IKO C-Lube Linear Roller Way Super MX

Block type mounting from top

MXD • LRXD

Shape

Size

10	12	15	20	25	30
35	45	55	65	85	

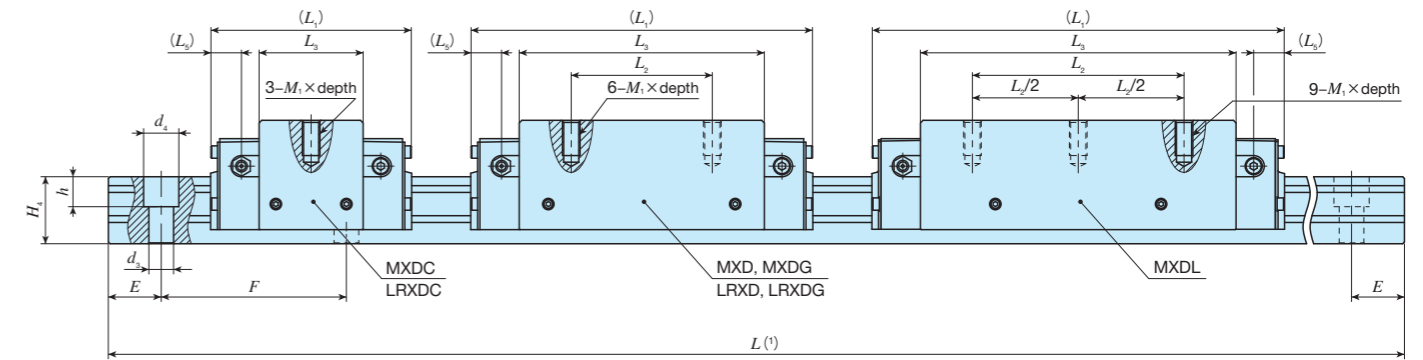
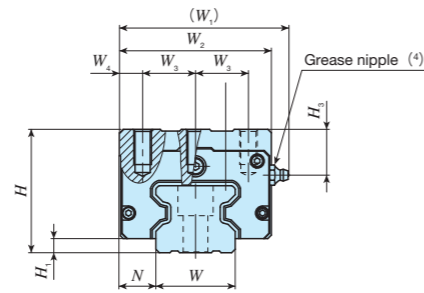

Identification number	Interchangeable	Mass (Ref.)		Dimensions of assembly mm								Dimensions of slide unit mm					Dimensions of track rail mm						Appended mounting bolt for track rail (2)	Basic dynamic load rating (3)	Basic static load rating (3)	Static moment rating (3)			
		Slide unit kg	Track rail kg/m	H	H1	N	W1	W2	W3	W4	L1	L2	L3	L5	M1 × depth	H3	W	H4	d3	d4	h	E				F	C	C0	T0
MXDC 35	○	0.97	6.88	55	6.5	18	78	70	25	10	92	—	46.6	12.7	M 8×16	20	34	32	9	14	12	40	80	M 8×35	39 500	60 000	1 300	506	506
LRXDC 35	○										12.5	12.7	12.5	3 950											3 950				
MXD 35	○										1.52	124	50	78.6											12.7	1 360	1 360		
LRXD 35	○										12.5	8 470	8 470																
MXDG 35	○	2.02	10.8	70	8	20.5	96	86	30	13	152	72	106.6	12.7	M 10×20	26	45	38	14	20	17	52.5	105	M 12×40	74 200	135 000	2 930	2 440	2 440
LRXDG 35	○										12.5	13 800	13 800																
MXDL 35	—										2.55	184	100	138.6											12.7	4 060	4 060		
—	—										12.5	21 300	21 300																
MXDC 45	○	2.01	10.8	70	8	20.5	96	86	30	13	114	—	59	17.5	M 10×20	26	45	38	14	20	17	52.5	105	M 12×40	64 100	95 600	2 660	1 010	1 010
LRXDC 45	○										12.5	7 800	7 800																
MXD 45	○										3.13	154	60	99											12.5	2 700	2 700		
LRXD 45	○										12.5	16 800	16 800																
MXDG 45	○	4.29	10.8	70	8	20.5	96	86	30	13	194	80	139	17.5	M 10×20	26	45	38	14	20	17	52.5	105	M 12×40	124 000	223 000	6 200	5 220	5 220
LRXDG 45	○										12.5	29 000	29 000																
MXDL 45	—										5.36	234	120	179											12.7	8 560	8 560		
—	—										12.5	44 400	44 400																

Notes (1) Track rail lengths L are shown in Table 2.1 on page II-175 and Table 2.3 on page II-176.
 (2) The appended track rail mounting bolts are hexagon socket head bolts equivalent to JIS B 1176. In an assembled set of MX series, track rail mounting bolts are not appended.
 (3) The direction of basic dynamic load rating (C), basic static load rating (C_0), and static moment rating (T_0 , T_x , T_y) are shown in the sketches below. The upper values of T_x and T_y are for one slide unit and the lower values are for two slide units in close contact.
 (4) The shapes of grease nipple vary by size. The specifications are shown in Table 15 on page II-188.
 Remark: Three grease nipple mounting thread holes are provided on the right and left end plates respectively.

Example of identification number of assembled set

Model code Dimensions Part code Preload symbol Classification symbol Interchangeable code Supplemental code

MXD **G** **35** **C2** **R1200** **T2** **P** **/F**

① ② ③ ④ ⑤ ⑥ ⑦ ⑧ ⑨

① Model	MXD LRXD	Block type mounting from top	③ Size	35, 45	⑥ Preload amount	No symbol Standard T1 Light preload T2 Medium preload T3 Heavy preload	⑧ Interchangeable	No symbol Non-interchangeable specification S1 S1 specification S2 S2 specification
② Length of slide unit	C Short No symbol Standard G Long L Extra long		④ Number of slide unit (2)		⑦ Accuracy class	H High P Precision SP Super precision UP Ultra precision	⑨ Special specification	A, D, E, F, HP, I, J, L, LF MA, MN, N, PS, Q, RC, T UR, V, W, Y, Z
			⑤ Length of track rail (1,200 mm)					

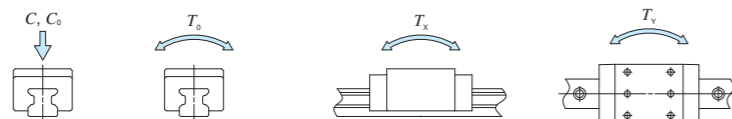

IKO C-Lube Linear Roller Way Super MX

Compact block type mounting from top

Shape	MXS • LRXS			
Size	15	20	25	30
	35	45	55	

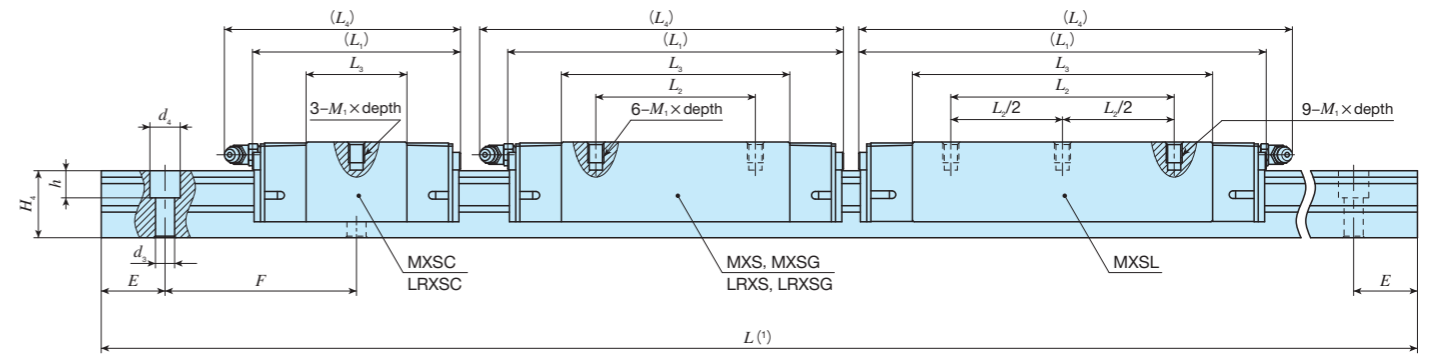
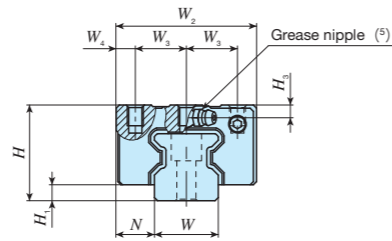

Identification number	Interchangeable	Mass (Ref.)		Dimensions of assembly mm											Dimensions of slide unit mm							Dimensions of track rail mm							Appended mounting bolt for track rail (3)	Basic dynamic load rating (4)	Basic static load rating (4)	Static moment rating (4)		
		Slide unit kg	Track rail kg/m	H	H1	N	W2	W3	W4	L1	L2	L3	L4	M1 × depth (2)	H3	W	H4	d3	d4	h	E	F	Bolt size × ℓ	C N	C0 N	T0 N · m	Tx N · m	Ty N · m						
MXSC 15	LRXSC 15	○	0.099	1.65	24	4	9.5	34	13	4	52	—	24	55	M4 × 5.5	3.5	15	16.5	4.5	8	6	30	60	M4 × 16	7 730	12 000	113	50.6	50.6					
MXS 15	LRXS 15	○	0.15								68	26	40	71											136	136								
MXSG 15	LRXSG 15	○	0.21								84	56	87	262											262									
MXSC 20	LRXSC 20	○	0.21	2.73	30	5	12	44	16	6	66	—	31.6	74	M5 × 6.5	4	20	21	6	9.5	8.5	30	60	M5 × 20	16 100	26 400	341	150	150					
MXS 20	LRXS 20	○	0.31								86	36	51.6	94											379	379								
MXSG 20	LRXSG 20	○	0.42								106	50	71.6	114											2 520	2 520								
MXSL 20	—	—	0.55								128	70	94.1	137											4 200	4 200								
MXSC 25	LRXSC 25	○	0.30	3.59	36	6	12.5	48	17.5	6.5	74	—	36	83	M6 × 9	5	23	24.5	7	11	9	30	60	M6 × 25	21 600	33 800	500	213	213					
MXS 25	LRXS 25	○	0.47								98	35	60	107											3 800	3 800								
MXSG 25	LRXSG 25	○	0.57								113	50	75	122											5 380	5 380								
MXSL 25	—	—	0.74								137	70	99	146											8 480	8 480								
MXSC 30	LRXSC 30	○	0.54	5.01	42	6.5	16	60	20	10	85	—	42.4	95	M8 × 11	6.5	28	28	9	14	12	40	80	M8 × 28	29 200	44 600	808	329	329					
MXS 30	LRXS 30	○	0.83								113	40	70.4	123											5 780	5 780								
MXSG 30	LRXSG 30	○	1.05								134	60	91.4	144											8 740	8 740								
MXSL 30	—	—	1.37								162	80	119.4	172											13 600	13 600								

Notes (1) Track rail lengths L are shown in Table 2.1 on page II-175 and Table 2.3 on page II-176.
 (2) For the fixing thread depth of the slide unit mounting hole, the value indicated in Table 16.1 on page II-190 is recommended.
 (3) The appended track rail mounting bolts are hexagon socket head bolts equivalent to JIS B 1176. In an assembled set of MX series, track rail mounting bolts are not appended.
 (4) The direction of basic dynamic load rating (C), basic static load rating (C_0), and static moment rating (T_0 , T_x , T_y) are shown in the sketches below. The upper values of T_x and T_y are for one slide unit and the lower values are for two slide units in close contact.
 (5) The shapes of grease nipple vary by size. The specifications are shown in Table 15 on page II-188.
 Remark: A grease nipple mounting thread hole is provided on the right and left end plates respectively.

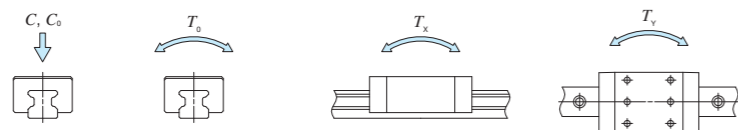

Example of identification number of assembled set

Model code Dimensions Part code Preload symbol Classification symbol Interchangeable code Supplemental code

MXS G 25 C2 R840 T1 P /F

① ② ③ ④ ⑤ ⑥ ⑦ ⑧ ⑨

① Model	MXS Compact block type mounting from top	③ Size	15, 20, 25, 30	⑥ Preload amount	No symbol Standard T1 Light preload T2 Medium preload T3 Heavy preload	⑧ Interchangeable	No symbol Non-interchangeable specification S1 S1 specification S2 S2 specification
② Length of slide unit	C Short No symbol Standard G Long L Extra long	④ Number of slide unit (2)		⑦ Accuracy class	H High P Precision SP Super precision UP Ultra precision	⑨ Special specification	A, D, E, F, HP, I, J, L, LF MA, MN, N, Q, RC, T, UR V, W, Y, Z
⑤ Length of track rail (840 mm)							

IKO C-Lube Linear Roller Way Super MX

Compact block type mounting from top

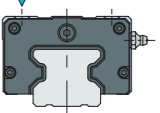
Shape	MXS			
				
Size	15	20	25	30
	35	45	55	

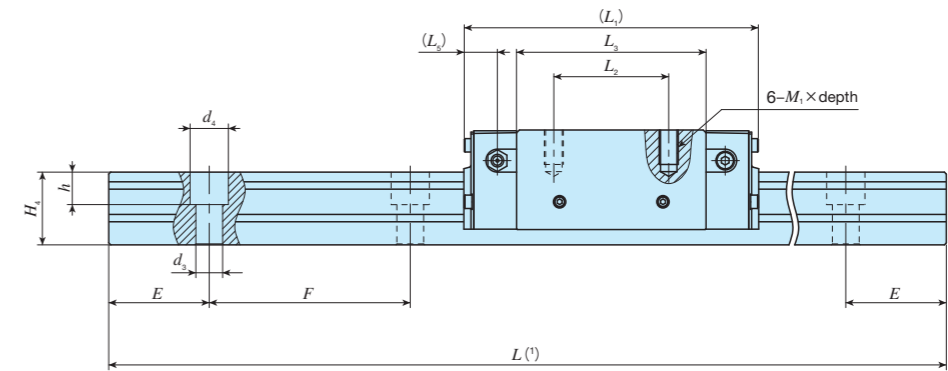
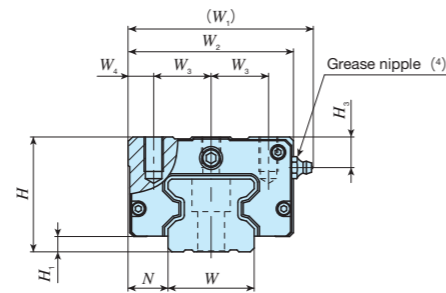

Identification number	Interchangeable	Mass (Ref.)		Dimensions of assembly mm								Dimensions of slide unit mm					Dimensions of track rail mm						Mounting bolt for track rail (2)	Basic dynamic load rating (3) C N	Basic static load rating (3) C ₀ N	Static moment rating (3)					
		Slide unit kg	Track rail kg/m	H	H ₁	N	W ₁	W ₂	W ₃	W ₄	L ₁	L ₂	L ₃	L ₅	M ₁ × depth	H ₃	W	H ₄	d ₃	d ₄	h	E				F	Bolt size × ℓ	T ₀ N · m	T _x N · m	T _y N · m	
MXS 35	○	1.22	6.88	48	6.5	18	78	70	25	10	124	50	78.6	12.7	M 8×12	13	34	32	9	14	12	40	80	M 8×35	58 700	100 000	2 170	1 360 8 470	1 360 8 470		
MXSG 35	○	1.61									152	72	106.6																		
MXS 45	○	2.37	10.8	60	8	20.5	96	86	30	13	154	60	99	17.5	M10×18	16	45	38	14	20	17	52.5	105	M12×40	95 400	159 000	4 430	2 700 16 800	2 700 16 800		
MXSG 45	○	3.27									194	80	139																		
MXS 55	○	3.96	14.1	70	9	23.5	110	100	37.5	12.5	184	75	120	20	M12×20	16	53	43	16	23	20	60	120	M14×45	148 000	248 000	8 040	5 040 31 100	5 040 31 100		
MXSG 55	○	5.63									238	95	174																		

Notes (1) Track rail lengths L are shown in Table 2.1 on page II-175 and Table 2.3 on page II-176.
 (2) Track rail mounting bolts are not appended.
 (3) The direction of basic dynamic load rating (C), basic static load rating (C_0), and static moment rating (T_0 , T_x , T_y) are shown in the sketches below. The upper values of T_x and T_y are for one slide unit and the lower values are for two slide units in close contact.
 (4) The shapes of grease nipple vary by size. The specifications are shown in Table 15 on page II-188.
 Remark: Three grease nipple mounting thread holes are provided on the right and left end plates respectively.

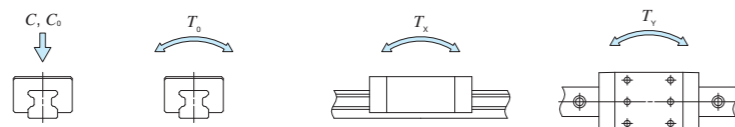

Example of identification number of assembled set

Model code Dimensions Part code Preload symbol Classification symbol Interchangeable code Supplemental code

MXS G 45 C2 R1470 T1 P /F

① ② ③ ④ ⑤ ⑥ ⑦ ⑧ ⑨

① Model	MXS Compact block type mounting from top	③ Size	35, 45, 55	⑥ Preload amount	No symbol Standard T1 Light preload T2 Medium preload T3 Heavy preload	⑧ Interchangeable	No symbol Non-interchangeable specification S1 S1 specification S2 S2 specification
② Length of slide unit	No symbol Standard G Long	④ Number of slide unit (2)		⑦ Accuracy class	H High P Precision SP Super precision UP Ultra precision	⑨ Special specification	A, D, E, F, HP, I, J, L, LF MA, N, RC, T, UR, V, W, Z
⑤ Length of track rail (1,470 mm)							

IKO C-Lube Linear Roller Way Super MX

Low profile flange type mounting from top

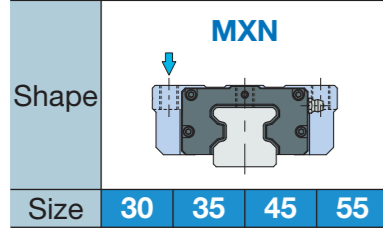

MXN 30
MXNG 30
MXNL 30

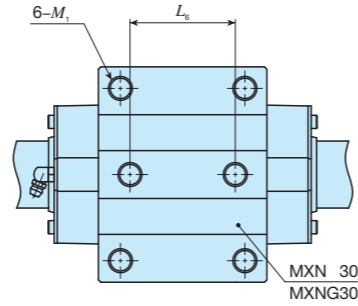
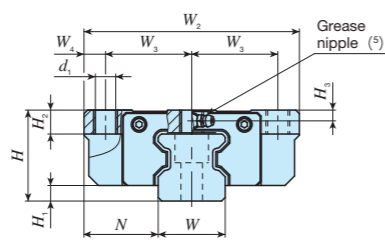

MXN
MXNG
MXNL

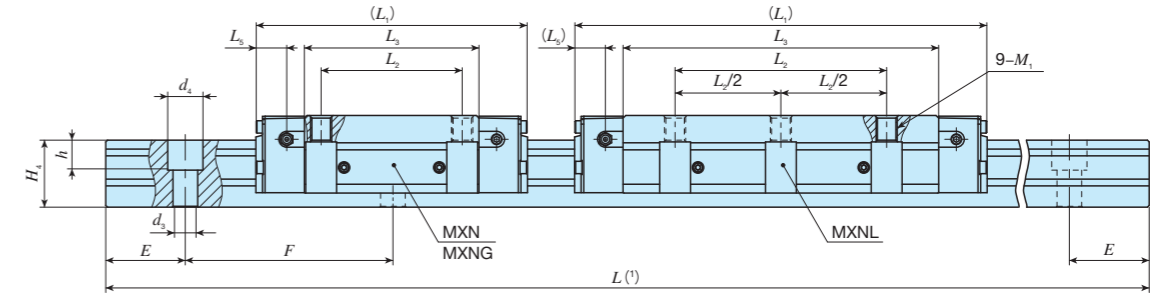
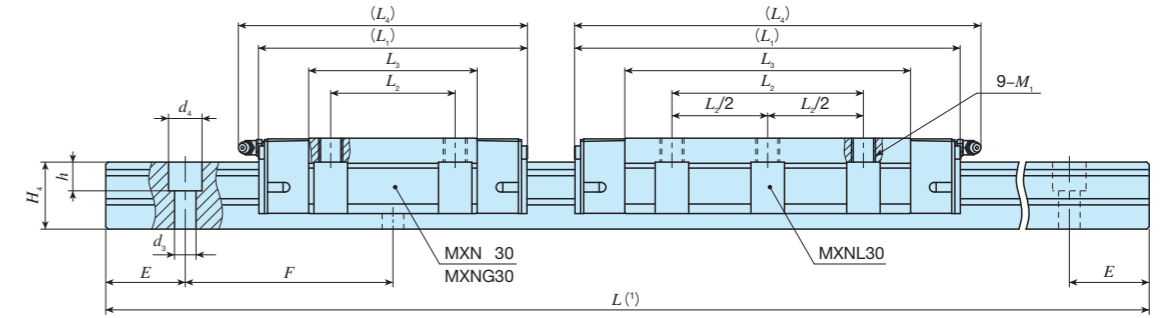
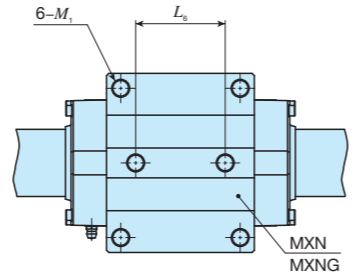
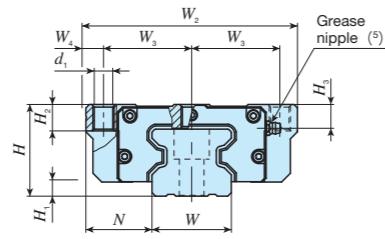

Identification number	Interchangeable	Mass (Ref.)	Dimensions of assembly mm	Dimensions of slide unit mm														Dimensions of track rail mm						Mounting bolt for track rail (3)	Basic dynamic load rating (4)	Basic static load rating (4)	Static moment rating (4)																
				Slide unit kg	Track rail kg/m	H	H1	N	W2	W3	W4	L1	L2	L3	L4	L5	L6	d1	M1	Maximum fixing thread depth (2)	H2	H3	W				H4	d3	d4	h	E	F	Bolt size x l	C	C0	T0	Tx	Ty					
MXN 30	-	1.05	5.01	38	6.5	31	90	36	9	113	52	70.4	121	-	44	8.5	M10	9	10	4.5	28	28	9	14	12	40	80	M 8x28	43 400	74 400	1 350	883	883										
MXNG 30	-	1.38								134		91.4	142																8.5	10	4.5	28	28	9	14	12	40	80	53 200	96 700	1 750	1 470	1 470
MXNL 30	-	1.75								162		119.4	170																80	10	4.5	28	28	9	14	12	40	80	65 600	126 000	2 290	2 500	2 500
MXN 35	-	1.55	6.88	44	6.5	33	100	41	9	124	62	78.6	-	52	8.5	M10	11	13	11	34	32	9	14	12	40	80	M 8x35	58 700	100 000	2 170	1 360	1 360											
MXNG 35	-	2.13								152		106.6																127	8.5	13	11	34	32	9	14	12	40	80	74 200	135 000	2 930	2 440	2 440
MXNL 35	-	2.71								184		138.6																100	10	11	34	32	9	14	12	40	80	90 800	175 000	3 800	4 060	4 060	
MXN 45	-	2.58	10.8	52	8	37.5	120	50	10	154	80	99	-	60	10.5	M12	13	15	13.5	45	38	14	20	17	52.5	105	M12x40	95 400	159 000	4 430	2 700	2 700											
MXNG 45	-	3.73								194		139																17.5	10.5	15	13.5	45	38	14	20	17	52.5	105	124 000	223 000	6 200	5 220	5 220
MXNL 45	-	4.72								234		179																120	10	13.5	45	38	14	20	17	52.5	105	151 000	287 000	7 980	8 560	8 560	
MXN 55	-	4.61	14.1	63	9	43.5	140	58	12	184	95	120	-	70	12.5	M14	19	17	16	53	43	16	23	20	60	120	M14x45	148 000	248 000	8 040	5 040	5 040											
MXNG 55	-	6.94								238		174																20	12.5	17	16	53	43	16	23	20	60	120	198 000	359 000	11 700	10 400	10 400
MXNL 55	-	8.87								292		150																228	12	16	53	43	16	23	20	60	120	244 000	470 000	15 300	17 700	17 700	

Notes (1) Track rail lengths L are shown in Table 2.1 on page II-175 and Table 2.3 on page II-176.

(2) The fixing thread depth of mounting screw in the middle of the way in the slide unit width direction should be less than the maximum fixing thread depth.

(3) Track rail mounting bolts are not appended.

(4) The direction of basic dynamic load rating (C), basic static load rating (C0), and static moment rating (T0, Tx, Ty) are shown in the sketches below. The upper values of Tx and Ty are for one slide unit and the lower values are for two slide units in close contact.

(5) The shapes of grease nipple vary by size. The specifications are shown in Table 15 on page II-188.

Remarks 1. For size 30 series, a grease nipple mounting thread hole is provided on the right and left end plates respectively.

2. For size 35, 45, and 55 series, three grease nipple mounting thread holes are provided on the right and left end plates respectively.

However, the size of thread hole for size 35 in the slide unit travelling direction is smaller than that of the crosswise direction.

When the grease nipple is mounted along the travelling direction, contact IKO.

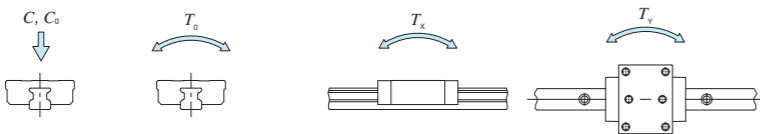

Example of identification number of assembled set

Model code Dimensions Part code Preload symbol Classification symbol Interchangeable code Supplemental code

MXN G 55 C2 R3000 T2 P /F

① ② ③ ④ ⑤ ⑥ ⑦ ⑧ ⑨

① Model	MXN Low profile flange type mounting from top
② Length of slide unit	No symbol Standard G Long L Extra long

③ Size	30, 35, 45, 55
④ Number of slide unit (2)	
⑤ Length of track rail (3,000 mm)	

⑥ Preload amount	No symbol Standard T1 Light preload T2 Medium preload T3 Heavy preload
⑦ Accuracy class	H High P Precision SP Super precision UP Ultra precision

⑧ Interchangeable	No symbol Non-interchangeable specification S1 S1 specification S2 S2 specification
⑨ Special specification	A, D, E, F, HP, I, J, L, LF MA, RC, T, UR, V, W, Z

IKO C-Lube Linear Roller Way Super MX

Low profile block type mounting from top

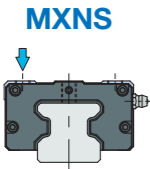
Shape				
Size	30	35	45	55

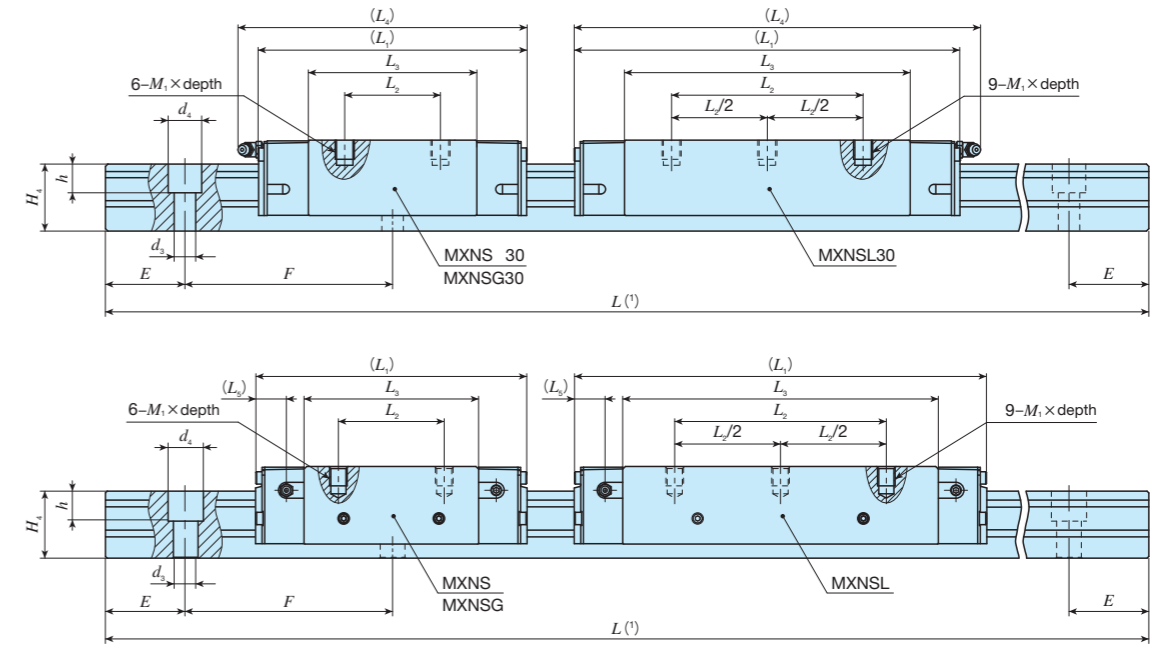
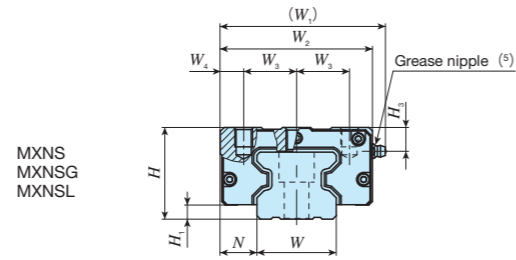
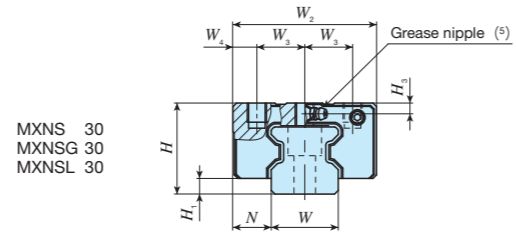

Identification number	LRX series (No C-Lube)	Interchangeable	Mass (Ref.) Slide unit kg / Track rail kg/m	Dimensions of assembly mm														Dimensions of slide unit mm										Dimensions of track rail mm						Mounting bolt for track rail (3) Bolt size x l	Basic dynamic load rating (4) C N	Basic static load rating (4) C0 N	Static moment rating (4)		
				H	H1	N	W1	W2	W3	W4	L1	L2	L3	L4	L5	M1 x depth (2)	Maximum fixing thread depth (2)	H3	W	H4	d3	d4	h	E	F	T0 N·m	Tx N·m	Ty N·m											
MXNS 30	-	○	0.70	5.01	38	6.5	16	-	60	20	10	113	40	70.4	121	-	M 8 x 8	9	4.5	28	28	9	14	12	40	80	M 8 x 28	43 400	74 400	1 350	883 5 780	883 5 780							
MXNSG 30	-	○	0.90		134	60	91.4	142	12.7	M 8 x 9	11	11	34	32	9													14	12	40	80	53 200	96 700	1 750	1 470 8 740	1 470 8 740			
MXNSL 30	-	-	1.14		162	80	119.4	170																								17.5	M10 x 11	13	13.5	45	38	14	20
MXNS 35	-	○	1.08	6.88	44	6.5	18	78	70	25	10	124	50	78.6	-	M 8 x 9	11	11	34	32	9	14	12	40	80	M 8 x 35	58 700	100 000	2 170	1 360 8 470	1 360 8 470								
MXNSG 35	-	○	1.42		152	72	106.6	12.7	M 8 x 9	11	11	34	32	9													14	12	40	80	74 200	135 000	2 930	2 440 13 800	2 440 13 800				
MXNSL 35	-	-	1.81		184	100	138.6																								17.5	M10 x 11	13	13.5	45	38	14	20	17
MXNS 45	-	○	1.84	10.8	52	8	20.5	94	86	30	13	154	60	99	-	M10 x 11	13	13.5	45	38	14	20	17	52.5	105	M12 x 40	95 400	159 000	4 430	2 700 16 800									
MXNSG 45	-	○	2.58		194	80	139	17.5	M10 x 11	13	13.5	45	38	14													20	17	52.5	105	124 000	223 000	6 200	5 220 29 000	5 220 29 000				
MXNSL 45	-	-	3.29		234	120	179																								20	M12 x 15	19	16	53	43	16	23	20
MXNS 55	-	○	3.31	14.1	63	9	23.5	110	100	37.5	12.5	184	75	120	-	M12 x 15	19	16	53	43	16	23	20	60	120	M14 x 45	148 000	248 000	8 040	5 040 31 100									
MXNSG 55	-	○	4.83		238	95	174	20	M12 x 15	19	16	53	43	16													23	20	60	120	198 000	359 000	11 700	10 400 57 000	10 400 57 000				
MXNSL 55	-	-	6.28		292	150	228																								20	M12 x 15	19	16	53	43	16	23	20

Notes (1) Track rail lengths L are shown in Table 2.1 on page II-175 and Table 2.3 on page II-176.
 (2) For the fixing thread depth of the slide unit mounting hole, the value indicated in Table 16.2 on page II-190 is recommended.
 The fixing thread depth of mounting screw in the middle of the way in the slide unit width direction should be less than the maximum fixing thread depth.
 (3) Track rail mounting bolts are not appended.
 (4) The direction of basic dynamic load rating (C), basic static load rating (C0), and static moment rating (T0, Tx, Ty) are shown in the sketches below. The upper values of Tx and Ty are for one slide unit and the lower values are for two slide units in close contact.
 (5) The shapes of grease nipple vary by size. The specifications are shown in Table 15 on page II-188.

Remarks 1. For size 30 series, a grease nipple mounting thread hole is provided on the right and left end plates respectively.
 2. For size 35, 45, and 55 series, three grease nipple mounting thread holes are provided on the right and left end plates respectively. However, the size of thread hole for size 35 in the slide unit travelling direction is smaller than that of the crosswise direction. When the grease nipple is mounted along the travelling direction, contact IKO.

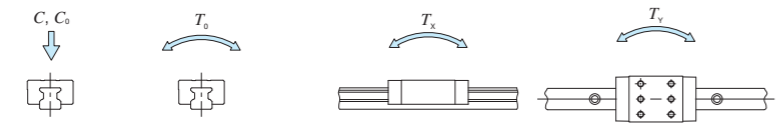

Example of identification number of assembled set

Model code: MXNS G Dimensions: 55 Part code: C2 R3000 Preload symbol: T2 Classification symbol: P Interchangeable code: /F

① Model: MXNS Low profile block type mounting from top

② Length of slide unit: G Long

③ Size: 30, 35, 45, 55

④ Number of slide unit (2)

⑤ Length of track rail (3,000 mm)

⑥ Preload amount: T2 Medium preload

⑦ Accuracy class: P Precision

⑧ Interchangeable: /F Special specification