

# Belt bunkers

Filling weight up to max. 5kg / 35kg

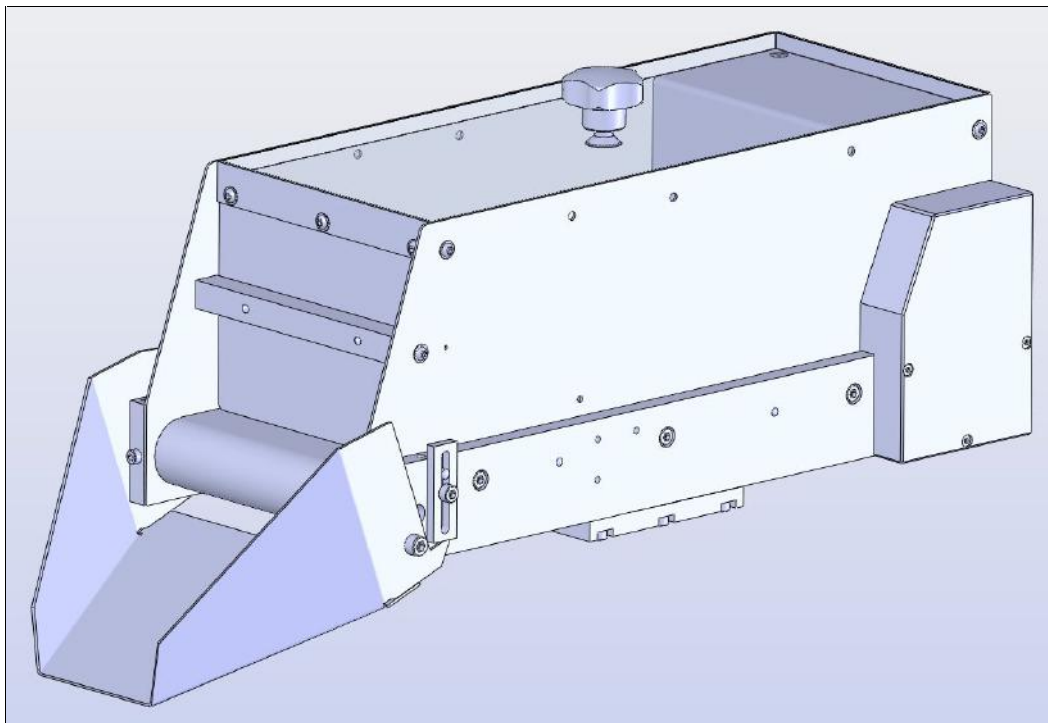

# Belt bunkers

Filling weight up to max. 5kg/35kg

## Contents

---

Section	Page
1. Belt bunkers - general	3
2. Belt bunkers up to maximum 5kg (B series)	4
3. Belt bunkers up to maximum 35kg (C series)	5
4. Belt bunker accessories	6
4.1. Filling level monitor	6
4.2. Level control type BSN	10
4.3. Dosing baffle	11
4.4. Lids	12
4.5. Stands / mounting	13
4.6. Installation of another belt	15
5. Belt bunkers and accessories - Price list	<b>Fehler! Textmarke nicht definiert.</b>

# Belt bunkers

Filling weight up to maximum 5kg/35kg

## 1. Belt bunkers - general

### Description:

The core of the belt bunker is a conveyor belt/transport belt on which parts move onto a sloped chute. To obtain a certain level of fill, a hopper is mounted on the belt. The transport belt is powered by a gear motor. The belt bunkers can be adapted individually irrespective of the parts they transport. Extensive accessory items adapt the belt bunker to different tasks.

Belt bunkers of different volumes and filling weights are available:

Besides, customized modifications/changes can be made to these different types. Special types/prototypes are available on request.

### Applications:

- Part provisioning for sorters and feeders (extended filling cycle intervals)
- Feeding of packaging machines and scales
- Dosed stocking of parts
- Optimization of the operating behavior of feeding units
- Reduction of the size of feeding units and cutting of costs, plus saving of space by eliminating the external provision of parts.

### Installation:

The belt bunker should be set up on a firm base, plate, stand, etc. The movement of the belt should not be obstructed by the installation of the bunker.

A base plate is provided on the underside of the belt bunker. The belt bunker can be fastened to the base by 4 bolts (M8 or M10 size). Besides, the base plate of belt bunkers type BB-05 and larger has several grid size 40 mm offset options.

**Note Belt bunkers have different screw connection patterns. Please consult the catalog for the connection pattern of your belt bunker type.**

Suitable stands and mounting plates can be found under accessories.

### Type key:

Example: **BB-02-B, white belt**



# Belt bunkers

Filling weight up to maximum 5kg/35kg

## 2. Belt bunkers up to maximum 5kg (B series)

### Technical specifications

- Max. filling weight: 5 kg
- Belt speed: 0.1 m /min
- Belt: white, FDA-approved  
black, not FDA-approved
- Belt tension: set at tensioning screws outside
- Bunker hopper: Stainless steel
- Outlet curtain: Vulkollan
- Chute: Stainless steel brushed, slope can be set (max. 45°)
- AC gear motor: IP50  
230V/50Hz and 115V/60Hz  
Power consumption 5 W
- Lid: Polycarbonate, non-hinged
- Surfaces: Drive guard RAL5021
- 3-meter connecting cable
- Other versions and data on request

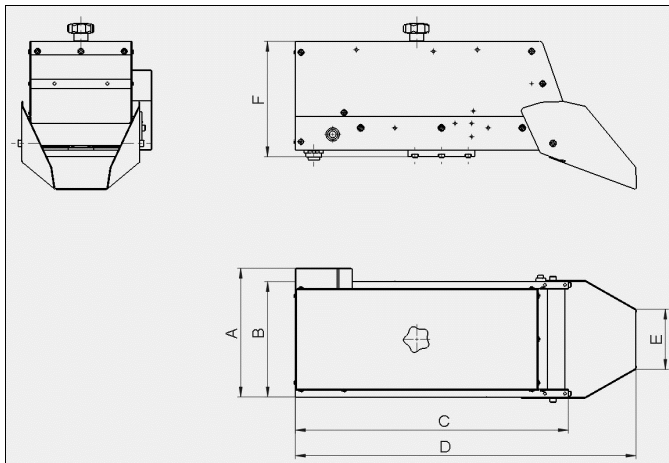

Base plate with grid pattern

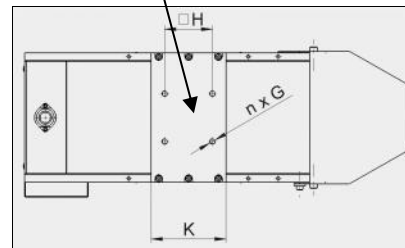

	A [mm]	B [mm]	C [mm]	D [mm]	E [mm]	F [mm]	K [mm]	H [mm]	n x G
<b>BB-01-B</b>	143	123	291.5	408	80	141.5	100	64	4 x M8
<b>BB-02-B</b>	143	123	291.5	413	80	181.5	100	64	4 x M8
<b>BB-05-B</b>	193	173	409.5	526	80	173	100	64	4 x M8

# Belt bunkers

Filling weight up to maximum 5kg/35kg

## 3. Belt bunkers up to maximum 35kg (C series)

### Technical specifications:

- Max. filling weight: 35 kg
- Belt speeds : 0,1 m /min (24V / 230V) or 0,6 m /min (230V)
- Belt: white, FDA-approved  
black, not FDA-approved
- Belt tension: set at tensioning screws outside
- Bunker hopper: Stainless steel
- Outlet curtain: Vulkollan
- Chute: Stainless steel brushed, slope can be set (max. 45°)
- motor: AC gear motor 230V/50Hz (standard configuration) or 115V/60Hz  
- Power consumption 7,2 W  
DC gear motor 24V (only for BB-05-C and BB-10-C)  
- Power consumption 4,3 W  
IP50
- Lid: Polycarbonate, non-hinged
- Surfaces: Drive guard RAL5021
- 3-meter connecting cable
- Other versions and data on request

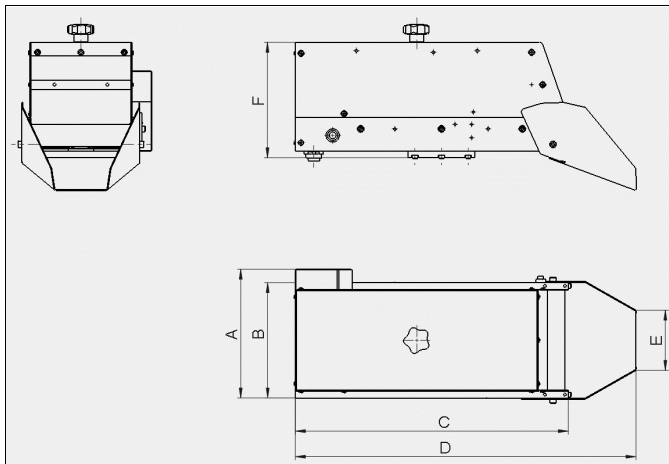

Base plate with grid pattern

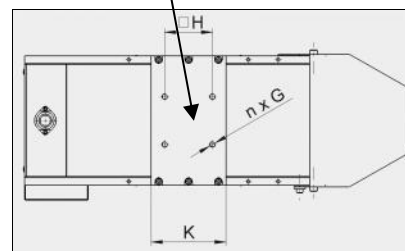

	A [mm]	B [mm]	C [mm]	D [mm]	E [mm]	F [mm]	K [mm]	H [mm]	n x G
<b>BB-05-C</b>	193	173	409,5	526	80	173	100	64	4 x M8
<b>BB-10-C</b>	243	223	447	628,7	80	215	100	64	4 x M8
<b>BB-20-C</b>	243	223	564,5	746	80	308	110	74	4 x M10
<b>BB-30-C</b>	343	323	564,5	747,7	180	308	110	74	4 x M10
<b>BB-50-C</b>	343	323	714,5	897,7	180	350	110	74	4 x M10

# Belt bunkers

## Accessories - level monitors

### **4. Belt bunker accessories**

#### **4.1. Filling level monitor**

##### **Filling level monitor in general**

Filling level monitors reporting part levels in the belt bunker or the hopper are available.

##### **Level monitors for belt bunkers in general**

The purpose of the level monitor is to warn the operator to replenish the stock of parts. The information can be generated in two different ways.

- Optically by one-way light barrier
- Reflection by ultrasonic sensor

Both systems are contactless.

The type of level monitor depends on the case on hand and the type of parts detected. The size and the belt of the belt bunker are also important.

Please contact us to be sure you choose the right type of level monitor for your belt bunker.

Let us know the details of your application.

##### **Belt bunker level monitoring from the side**

In this case, a one-way optical barrier is used,

- Installed to belt bunkers type BB-02-B and higher
- Operates without contact
- Is attached at the side of the belt bunker
- The light beam requires a hole of approx. 3 mm diameter

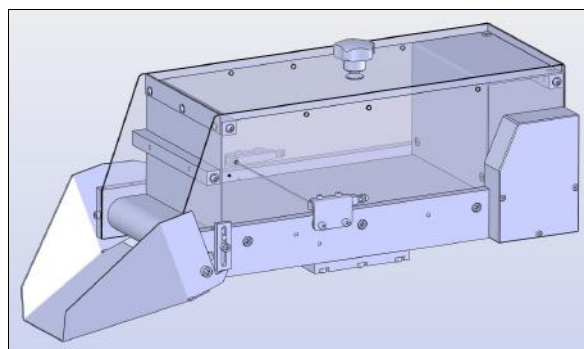

Designation: ZFSKB one-way

# Belt bunkers

## Accessories - level monitors

---

### Belt bunker level monitoring from top

In this case, an ultrasonic sensor is used.

- The type depends on the material, the surface finish and the shape of the parts detected
- Works from top
- Operates without contact

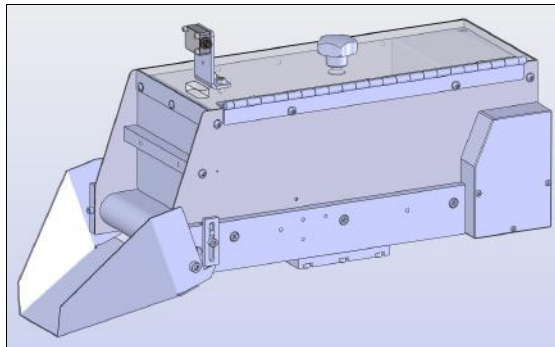

Designation: ZFSKB-Ultra

# Belt bunkers

## Accessories - level monitors

### Level monitoring for bowl feeder in general

The purpose of the level monitor in the bowl feeder is to maintain the optimum or minimum level of parts in the vibration helical or other feeder. The signal controls the automatic replenishment of parts or warns the operator to add parts. The information can be generated in two different ways.

- Electro-mechanically by pendulum
- Reflection by ultrasonic sensor

The first version requires physical contact whereas the other version works without contact, that is the parts are not exposed to stress.

The type of level monitor depends on the case on hand and the type of parts detected. The size and the design of the feeder bowl is important.

### Level monitoring in bowl feeder by pendulum

- Electro-mechanical component for level scanning in the feeder bowl
- The level is monitored by a pendulum
- The size of the boom can be customized
- The parts are touched

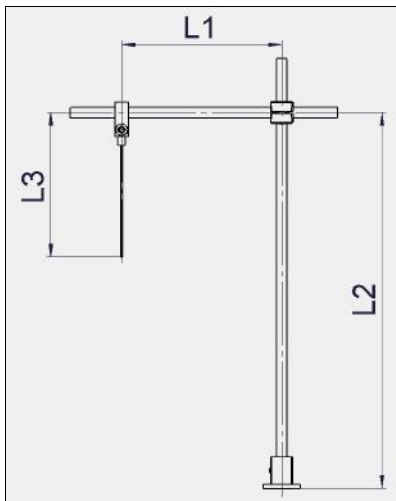

Designation: ZFSKT pendulum

Length: L1 standard 300 mm  
L2 standard 400 mm  
L3 standard 200 mm

Other lengths on request



# Belt bunkers

## Accessories - level monitors

### Level monitoring in bowl feeder by ultrasonic sensor

- Level scanned in the feeder bowl by ultrasonic sensor
- Operates without contact
- The size of the boom can be customized
- Detection range: 25 – 400mm
- Cross member of hinged design

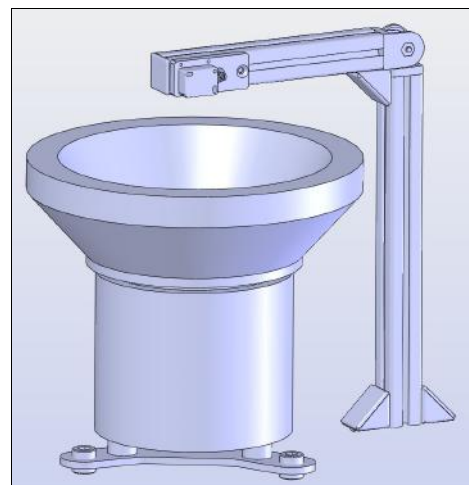
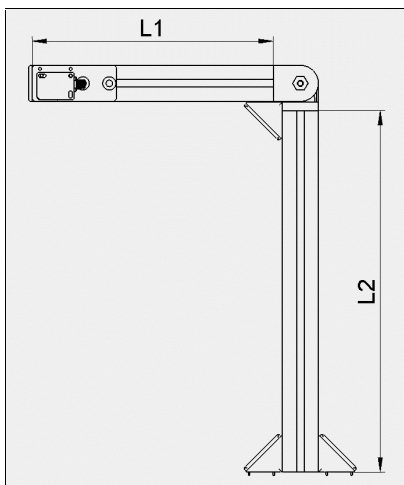

Designation: ZFSKT-Ultra

Length: L1 standard 300 mm  
L2 standard 400 mm

Other lengths on request

# Belt bunkers

## Accessories – level control

### 4.2. Level control type BSN

#### Level controls in general

The level controls turn the belt bunker on or off as a function of the level of the downstream components they monitor.

The level is controlled by the sensor at a defined position. The sensor output voltage is 0V when parts are present. The belt bunker is turned off.

If the level drops below minimum, the sensor output voltage switches to 24V. Now +24V is available at the sensor output and the voltage supply to the belt bunker is switched on after approximately 2-3 seconds. The belt bunker is turned on.

Level control type BSN 3/3Ph have jumpers by which the voltages can be changed and the signal voltages reversed.

#### Technical specifications:

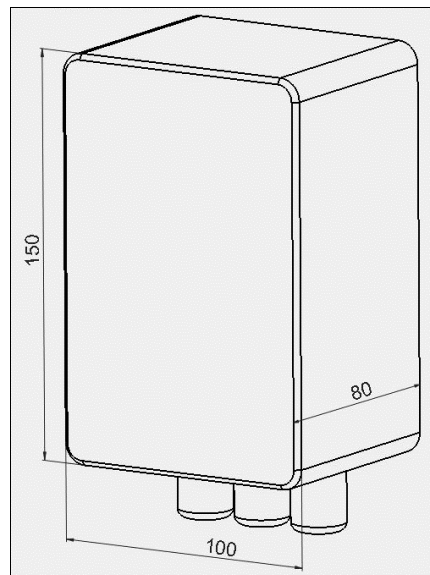

Designation: BSN-3/1Ph - BSN-3/3Ph

# Belt bunkers

## Accessories – Level control / dosing baffle

		BSN-3/1Ph	BSN-3/3Ph
<b>Mains supply</b>	230 V AC / 50 Hz	x	x
	115 V AC / 60 Hz	x	x
	3 ph. 400 V AC / 50Hz		x
	3 ph. 200 V AC / 60 Hz		x
	Output fused	T 3A	T 3.15 A (3x)
<b>Sensor connection</b>	24 V DC	x	x
	Signal reversion		x
<b>Enable input</b>	24 V	x	x
(blocks the BSN output)	Signal reversion	x	x
<b>Operating voltage</b>	24 V DC / max. 250mA	x	x

### 4.3. Dosing baffle

The dosing baffle restricts the outlet aperture of the belt bunker and keeps it at a defined size. This is helpful particularly with heavy parts which cannot sufficiently be withheld by the curtain.

When ordered as a complete unit, the dosing baffle is installed mechanically in the belt bunker.

If you want to service fit the dosing baffle, the bottom horizontal bar must be shifted; this means you have to drill 2 holes in the side walls. To make installation simple, punch-marks are provided where the holes for the screws must be drilled. Please specify the type of bunker for which you order the dosing baffle.

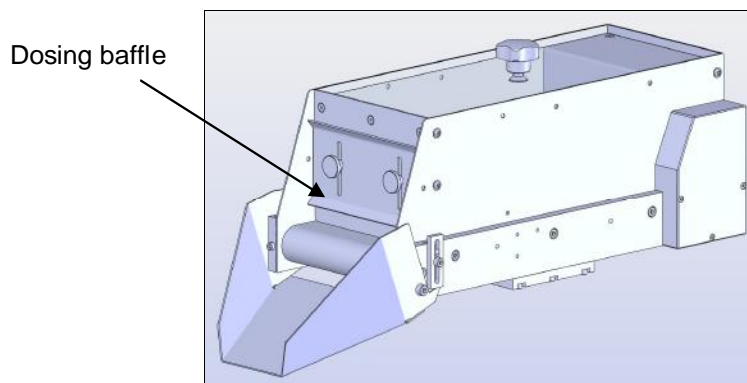

Designation: ZDB ... „specify bunker type“

# Belt bunkers

## Accessories - lids

### 4.4. Lids

#### Non-hinged lid

A non-hinged lid in place is standard for every belt bunker.

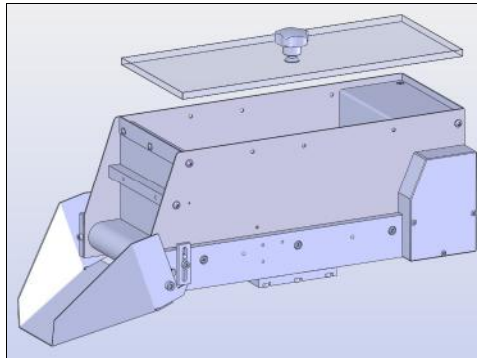

Designation: ZD – Non-hinged lid

#### Hinged lid

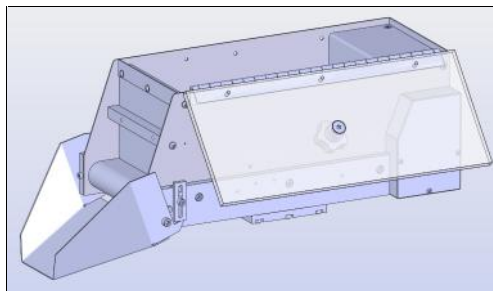

Designation: ZDKR – Hinged lid, right  
ZDKL – Hinged lid, left

Right or left indicates the position of the hinge in conveying direction.

# Belt bunkers

## Accessories – Stands / mounting

---

### 4.5. Stands / mounting

There are 2 versions of stands for belt bunkers:

- Table-top stands
- Floor stands

Both stand types fix the belt bunker to a firm base.

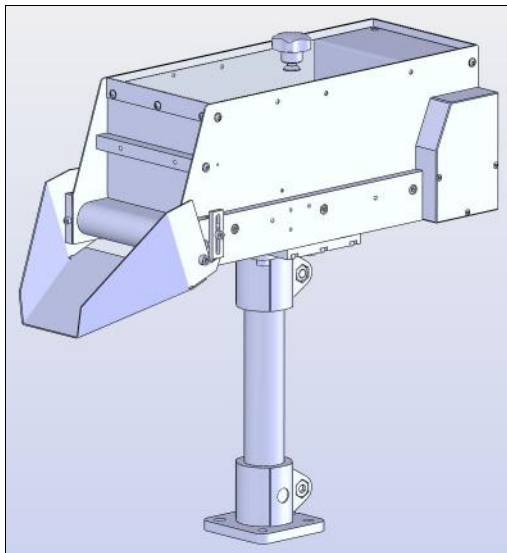

In addition to the table-top stand, floor stands can be delivered on request.

### Note

**Belt bunkers have different screw connection patterns. Please consult the appropriate pages of the belt bunker catalog.**

# Belt bunkers

## Accessories – Stands / mounting

### Table-top stands

The table-top stand is fixed to the foot plate of the belt bunker by 4 M8 / M10 size bolts. The height, H, of the table-top stand varies; most stands are at least 200 mm long.

We make table-top stands as required by you.

#### Belt bunker 1 Liter to 10 Liters

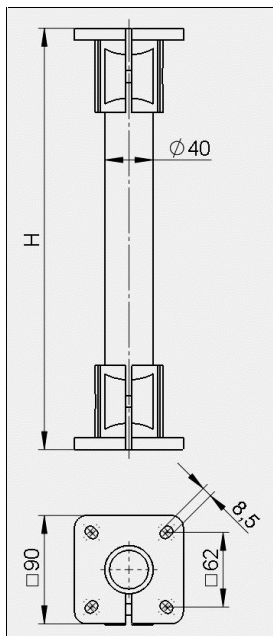

Designation:  
ZTS-40 H = ... „customer specification“

#### Belt bunker of 20 Liters and larger

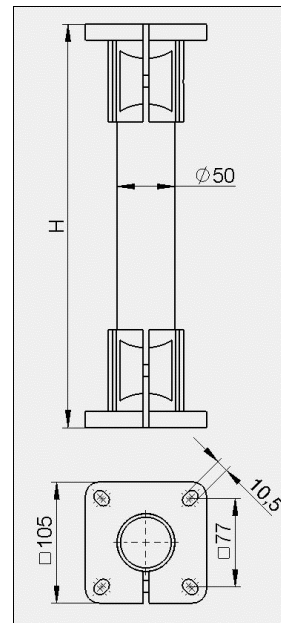

Designation:  
ZTS-50 H = ... „customer spec.“

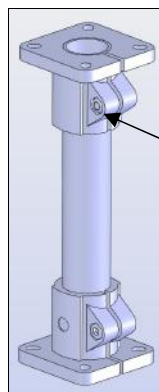

The bunker can be removed / pivoted at any time after removing the screw

# Belt bunkers

## Accessories - Belts

### 4.6. Installation of another belt

The standard bunker types are shipped with a white belt type.

In addition, our belt bunkers (BB-xx-B and BB-xx-C) are available with black belts ex stock.

If you need other belts, please contact us.

#### Belt characteristics / approvals:

	White Belt (G10)	Black belt (G11)
<b>Thickness [mm]</b>	1,8	2,1
<b>Conveying side</b>	Thermoplastic polyurethane (TPU), smooth, matt	Polyvinylchloride (PVC)
<b>Special features</b>	Abrasion resistant; easy cleanability; smooth and pore-free belt surface	Abrasion resistant; Low noise applications
<b>Mode of use/Conveyance</b>	Horizontal, inclined	Accumulation; Horizontal
<b>Antistatically equipped</b>	Yes	Yes
<b>Flammability</b>	No specific flammability prevention property	classified according to UL94HB(USA), HB = Horizontal Burning
<b>Food suitability FDA</b>	Yes - acc. to 21CFR parts 170 - 199	No use intended
<b>Food suitability USDA</b>	No use intended	No use intended
<b>Food suitability EU</b>	Yes - acc. to Regulation (EC) No. 1935/2004 and Regulation (EU) No 10/2011 as amended	No
<b>Other approvals</b>	None	None