

# Saturn S6

REVOLUTIONIZE YOUR  
END-OF-LINE [PACKAGING]  
PERFORMANCE

MOSCA

EN

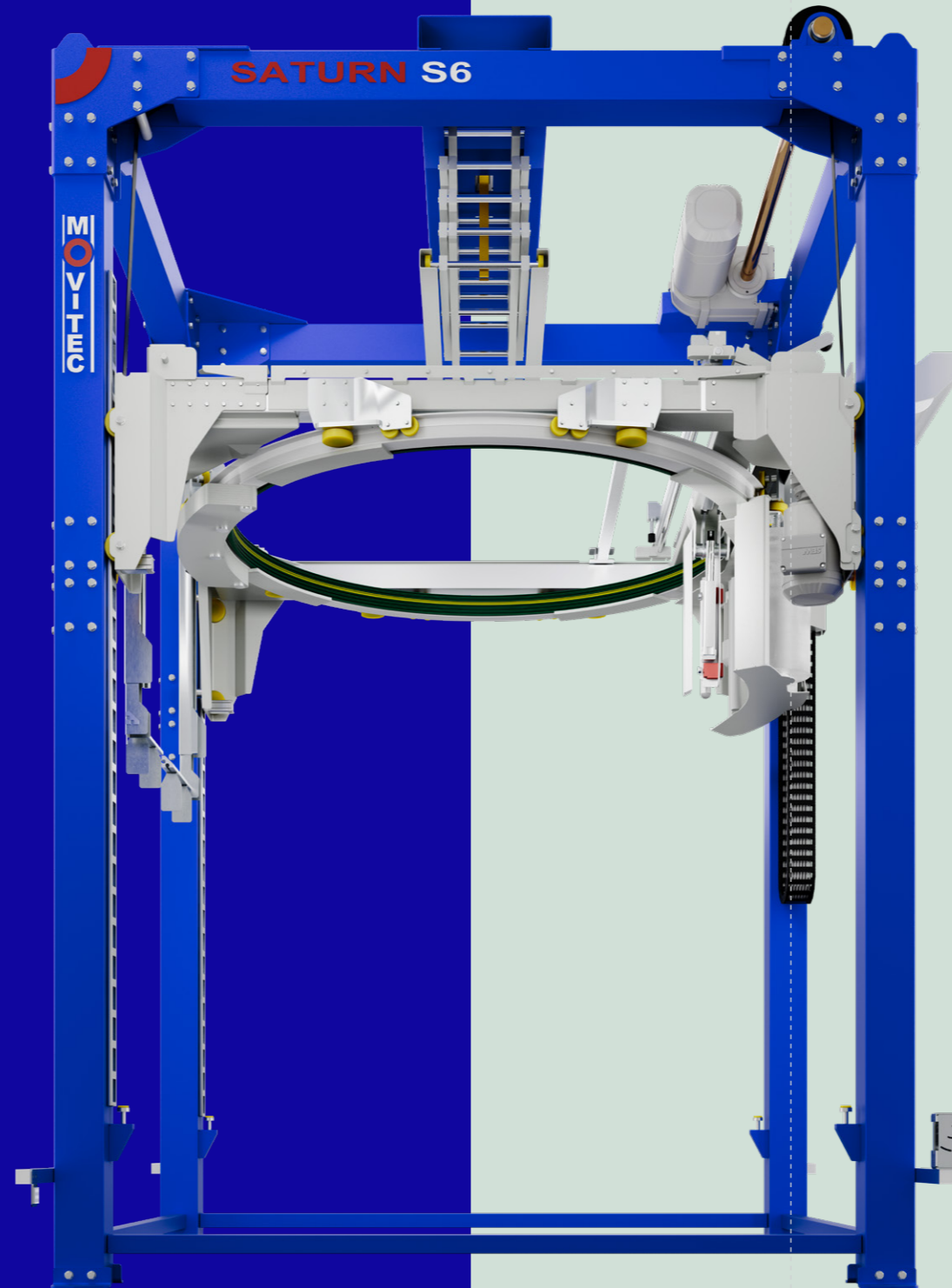

NONSTOP RESPONSIBLE  
NONSTOP RELIABLE  
NONSTOP INTELLIGENT  
NONSTOP PROGRESSIVE

Automatic Rotary Ring  
Stretch Wrapping Machine



High performance:  
Up to 120 pallets per hour



The most versatile: It can be upgraded to a  
Saturn S8 model to get higher performance



Counter plate seaming



Ring lift up / down movement  
by lifting belts



NONSTOP PERFORMANCE

# Saturn S6

## AUTOMATIC ROTARY RING STRETCH WRAPPING MACHINE

The versatile model Saturn S6 is our best-selling and most extensible rotary ring stretch wrapper. The film reel is mounted on the ring, which rotates concentrically to the load going up and down depending on the wrapping cycle, so the load remains static.

The ring technology of the Saturn S6 has a more balanced system with less wear and less maintenance compared to other technologies available in the wrapping industry. The S6 operates in the high performance range and can handle up to 120 pallets per hour.

Thanks to the elastic film and the optional top sheet dispenser, the load is not only optimally protected against damage, but also against moisture and dust.

### TECHNICAL DATA

Performance:  
 D17\*: Up to 120 pallets/h  
 D20: Up to 110 pallets/h  
 D23: Up to 90 pallets/h  
 D26: Up to 85 pallets/h  
 D29: Up to 75 pallets/h  
 \* Palet diagonal D: 1,750 mm | 2,050 mm | 2,300 mm | 2,600 mm | 2,900 mm

Stretch wrapping film:  
 Max. width: 500 mm  
 Max. diameter: 250 mm  
 Core diameter: 76 mm  
 Film thickness: 10 - 35 µ

Top film:  
 Max. height: 1,600 mm (D17) | 1,800 mm (D20) | 2,000 mm (D23/D26/D29)  
 Max. diameter: 300 mm  
 Inner core diameter: 76 mm  
 Film thickness: 30 - 90 µ

Load dimensions: (in mm)

	D17	D20	D23	D26	D29
Max. width	1,100	1,300	1,500	1,800	1,800
Max. diagonal	1,750	2,050	2,300	2,600	2,900
Max. height	2,100 (conveyors height 500mm)*				

\* Possibility to adapt the frame of the machine for loads higher than 2,100mm

Electricity:  
 Voltage: 400 V, 50 Hz, 3P+N+PE  
 (others on request)  
 Power consumption: Depending on model / options

Air connection:  
 Compressed air: 6 bar  
 Air consumption: 34 NI / cycle  
 Air consumption with top sheet film: 42 NI / cycle

Conveyor technology and height:  
 Rollers, chains, belts or without conveyor technology,  
 80 mm to 1,000 mm high

Weight: (without options)  
 approx. 2,000 kg

### STANDARD FEATURES

Guaranteed savings of stretch film: 300 % film pre-stretching; 1m of film becomes 4 m

Finishes without tails of film due to our efficient cut and welding device

Electronic and self-adjusting tension control depending on the profile of the load

Capable of applying bands (strips) at any height of the load

Possibility of wrapping at ground level

Possibility of applying efficient dustproof and rainproof wrappings

### OPTIONS

Top sheet dispenser for dustproof and rainproof wrappings

Motorized hold down plate

Roping device

Edge protection applicator

EPS - Electronically variable, 2-motor film pre-stretching system up to 400 %

ARC - Automatic Reel Change

### CONTACT US FOR A PERFORMANCE CONSULTATION!

mosca.com

Mosca GmbH  
 Gerd-Mosca-Straße 1 · 69429 Waldbrunn

info@mosca.com · +49 6274 / 932-0

### DIMENSIONS / WORKING WIDTH MACHINE (in mm; Picture includes options)

