

**Separator with Crusher
Model CD3-2020**

OPERATOR'S MANUAL



Allure

Vestra salus - nostra salus

“Allure”LLC

DECEMBER 2020

Data for identification

The name and address of the manufacturer	ALLURE LLC 107023, Russia, Moscow, Electrozavodskaya str.,21
Phone	+7 (495) 989 42 90
Fax	+7 (495) 989 42 90
E-mail	sp79653113668@gmail.com

ATTENTION!

Before starting operating the Machine the Manual should be read by operators, repairers and others who are responsible for the transportation of the product, its installation, commissioning, service and maintenance.

Please read the operating instructions and the safety rules given in this manual.

Do not start work until fully reading and understanding the material contained in this manual and other documentation supplied.

All security recommendations in the manual are obligatory.

Manual must be kept in accessible place for service personnel.

In addition to the measures referred to in the Manual, the law on the bases of labour protection and the rules for accident prevention and environmental protection in accordance with applicable laws should be observed.

Security must be in first priority when using the separator and crusher.

Manual does not reflect the minor design changes in equipment made by the manufacturer after the signing of the release of this guide, as well as for accessories and documentation coming with them. It only means that the separator with the crusher is improved to better meet your requirements.

ATTENTION!

Operating manual applies to the separator with Crusher with complete set of all units and does not take into account the changes reflected in the contract.

Table of Contents

1. Introduction	4
2. General information	4
2.1. Machine designation	4
2.2. Personnel qualification	4
2.3. Declaration of conformity	5
2.4. Manufacturer's warranty and liability	7
2.5. The overall view and the scope of equipment	7
2.6. Principle	8
2.7. Operating Control	9
3. Technical data and specifications	10
3.1. Technical data of the Machine	10
3.2. Electrical connection Conditions of the Machine	10
4. Security	10
4.1. General requirements for the safety	10
4.2. Security measures	10
4.3. Security measures for transportation and installation of the Machine	12
4.4. Security measures on preparing the Machine to work	13
4.5. Safety while running Machine	13
4.6. The technical design changes	15
4.7. Noise level	15
4.8. The residual risks	15
5. Package, marking, packing, storage, unpacking and transportation	15
5.1. The scope of supply	15
5.2. Marking	16
5.3. Packaging	17
5.4. Acceptance	17
5.5. Storage	17
5.6. Unboxing	17
5.7. Transport	17
6. Installation and initial start-up	19
6.1. Installation location and foundation	19
6.2. The climatic conditions	19
6.3. Installation of separator with crusher and preparation to start-up	20
7. Order of operation	20
7.1. Switching on/off the Machine	20
7.2. Emergency Shutdown of Machine	21
8. Maintenance	21
8.1. General safety instructions for maintenance	21
8.2. Scope of maintenance work	22
9. Spare parts Order, Calling customer service	25
10. Additional characteristics of equipment	26

1. Introduction

This "User's Manual" (the Guide) on the Machine should be seen as an integral part of the Machine and must be accessible for maintenance personnel.

Purpose of these guidelines is to provide all the information needed for transportation, commissioning, operation and maintenance of the product. The Manual provides guidelines for the safe, appropriate and cost-effective operation of the Machine. For the units of the Machine, for which it is appropriate, the Guide includes instructions for maintenance, replacement and adjustment. Compliance with these instructions helps avoiding danger, reduce downtime and repair costs, increase reliability and extend the lifetime of the Machine.

This guide has the sign of attention, with the following meaning:



The sign is put where it is necessary to be especially careful, precisely follow the requirements and instructions to avoid violations of the technological process and breaking the Machine.



Only a thorough daily implementation of guidelines to ensure the safety, maintenance of the Machine with care can ensure successful operation!

Failure to comply with the requirements of this manual frees the manufacturer from liability.

Use of the Machine for other purposes than specified in this guide, is not permitted. The company "Allure" is not responsible for damage caused by non-compliance with instructions and guidelines outlined in this Manual.

If there are issues that you cannot resolve yourself, consult with the customer service of the "Allure" company



Any request to perform work by our specialists should have indication to the model of Machine, serial number and the contract number.

2. General information

2.1. Designation of the Machine

This manual applies to a Separator with a crusher equipped with a module for separating cocoa nibs into fractions, model CD-3 (hereinafter referred to as a Separator with a crusher), designed for:

- grinding cocoa beans;
- separation of cocoa nibs from cocoa vella (husk);
- separation of cocoa nibs into fractions.

2.2. Personnel qualification



Installation, commissioning, operation, maintenance and repair is allowed by personnel qualified and trained to work with Machin . Staff qualification must be proved by proper documents.

The owner or his authorized representative is responsible for training the untrained personnel and the necessary training of qualified personnel of the rules of safe operation and maintenance of Machine.

The staff which is being trained should work on the Machine only under the supervision of an experienced person authorized to provide training.

Staff training to operate the Machine by the LLC "Allure" company specialist can be done at the time of commissioning, or on the LLC "Allure" factory facilities.

We recommend the company, which uses the **Machine**, To Issue internal instructions, taking into account the professional expertise of the staff and, in all cases, documenting studying this Manual and implementation of instruction or training.

- Operator**
- Trained personnel/specialist
 - Instruction at the workplace
 - Training by the manufacturer

- Service-mechanic**
- Specialist
 - Instruction at the workplace
 - Training by the manufacturer

- Service - electrician**
- Specialist
 - Instruction at the workplace
 - Training by the manufacturer

The management of the plant operating the Separator with Crusher must periodically check the qualifications of the personnel and the safety of their work.



Please make an entry in the registry log of "Registration of staff development and maintenance verification".

2.3. Declaration of conformity

While designing the Machine, selection of parts materials and its units, selection of components, manufacturing the Machine – the conformity with the following European security standards, directives and safety regulations is ensured:

- (E)N 954-1 safety of machinery. Details of control systems for safety. Part 1. The basic principles of design.
- EN1005-2 safety of machinery. The physical characteristics of the person. Part 2. Manual handling of machinery and component parts of machinery.
- EN1005-3 safety of machinery. The physical characteristics of the person. Part 3. Recommended limits of efforts for the operation of the machines.
- GOST r 51333-99 (EN 292-1-91, EN 292-2-91).Safety of machinery. Basic concepts, general principles for design. Terms, technology solutions and specifications.
- GOST r 51334-99 (eN 294-92), safety of machinery. Safety distances for the protection of the upper body parts from getting into the danger zone.

- GOST r 51335-99 (eNo. 349-93) safety of machinery. Minimum distances to prevent jamming of the human body parts.
- GOST r 51337-99 (eN 563-94), safety of machinery. Temperature of those surfaces. Ergonomics data to establish limit values for hot surfaces.
- GOST r 51339-99 (eN 811-96), safety of machinery. Safety distances to prevent lower limbs from getting into the danger zone.
- GOST r 51343-99 (eN 1037-95), safety of machinery. Prevention of unexpected start-up.
- GOST r 51344-99 (eNo. 1050-96), safety of machinery. Principles of risk assessment.
- GOST r 51345-99 (e# 1088-95), safety of machinery. Locking device of protective units-principles of selection and technical design.
- GOST r MEK 60204-1-99 (eN 60204-1) safety of machinery. Electrical equipment of machines and mechanisms. Part 1: General requirements.
- EU directive on machinery (98/37/EG).
- EU directive on electrical equipment designed for use within certain voltage limits (73/23/EEC).
- GOST 12.2.003-91. system of labour safety standards. Production equipment. General safety requirements.

**The Director General
LLC “Allure” G.V. Korotkov**



2.4. Manufacturer's warranty and liability

The manufacturer guarantees the compliancy of Machine with the above standards, directives and regulations, subject to following the terms of transportation, storage, installation and operation of the Machine, as set out in this guide.

The warranty period of exploitation for which the manufacturer undertakes to repair or replace the Machine on manufacturer's fault, is 6 months unless otherwise agreed in the contract.

The beginning of the warranty period is calculated from the date of putting the Separator-crusher into operation, but no later than 6 months from the date of receipt of the Separator-crusher from the manufacturer's warehouse.



The manufacturer is not liable for personal injury or material damage if they are the result of:

- *non-observance of the rules of storage of the Separator-crusher set forth in the Manual;*
- *unintended use of the Separator-Crusher;*
- *improper handling of the Crusher Separator during maintenance and operation;*
- *non-observance of the instructions set out in the Manual at any of the stages of handling the Separator-Crusher;*
- *operation of the Separator-Crusher with incorrectly installed, inoperative or faulty protective devices, as well as when they are removed or ignored;*
- *changes in the parameters or design of the Separator-Crusher, not agreed with the manufacturer;*
- *increased wear due to insufficient maintenance;*
- *improper performance of repair work.*

2.5. The general view of the separator with a crusher

General view of the separator with crusher is presented in Fig. 1.

The location and description of Separator with Crusher parts are presented on Figure 2.

List of components of the separator with a crusher is given in table 1.

Fig. 1

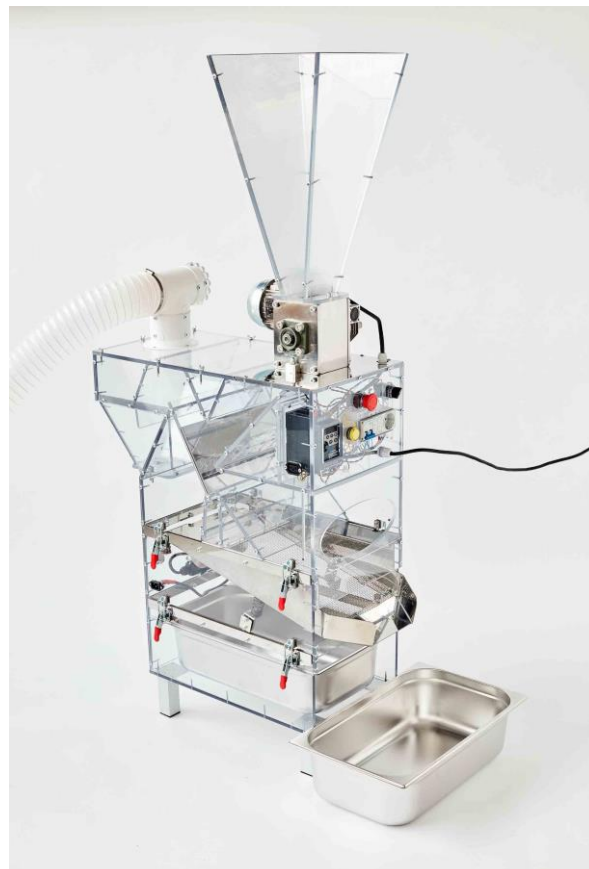

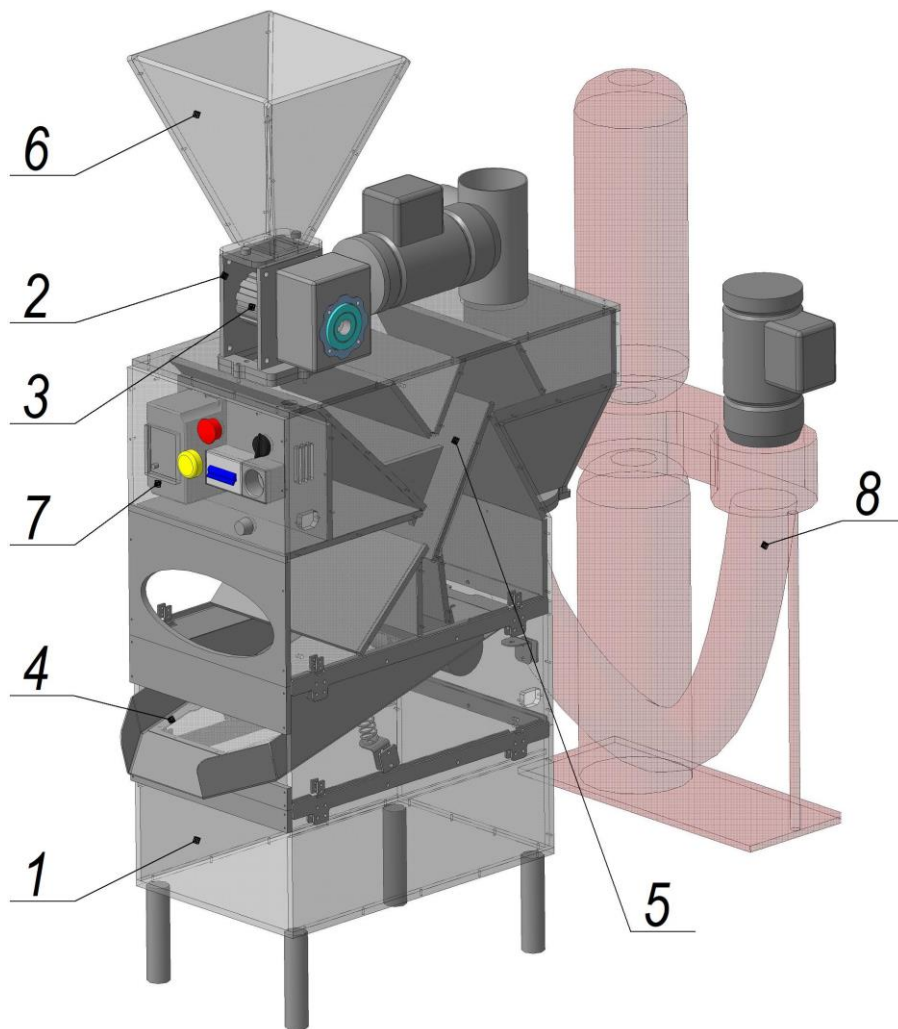

Figure 2

Table 1. List of parts for Separator / Crusher

Description	Pos. on the figure. 2
Compartment for accommodating a gastronome container for receiving fine cocoa nibs	1
The crushing mechanism	2
Crusher roller	3
Removable module for separating cocoa nibs into fractions with a tray for unloading cocoa nibs.	4
Guides of the aspiration chamber	5
Loading hopper for cocoa beans.	6
The control unit	7
Air flow device	8

2.6. Principle

Cocoa beans are poured into hopper 6 (Fig. 2.). The crushing of cocoa beans is carried out in the crushing mechanism 2 by the roll 3. The gap in the crushing mechanism when the roll rotates in the forward direction is 3 mm (in the opposite, reverse direction of rotation, 5 mm). The crushing products enter the aspiration chamber 5, where, under the action of aerodynamic forces, the mixture is separated into cocoa nibs and vella (husks). Cocoa nibs less than 4 mm in size are collected in the internal gastronomie container 1. Cocoa nibs with a size of four or more millimeters are removed from the separation module 4 into the external gastronomie container. The operation of the device is controlled from the control unit 7.

2.7. Controls

The controls are located on the Separator-Crusher control unit (Fig. 3). The Separator with a crusher is controlled by signals from the control unit.

- power cord 1 for connecting to a 220 Volt power supply;
- automatic overcurrent protection 2 (when the overcurrent protection is triggered, the Separator-crusher is automatically turned off);
- relay of the general power supply of the crusher-separator 9;
- relay for switching on the vibration motor of the removable separation module 10;
- indicator 3 indicates that the power supply is on;
- knob 4 for changing the rotation frequency of the crushing mechanism roll;
- indicator 5 shows the rotational speed of the crusher;
- red switch 6 for emergency shutdown of the separator-crusher;
- switch 7 of the direction of rotation of the crushing mechanism roll in forward and reverse directions. The forward direction of rotation is designated "Normal beans" (NB). Reversible - "Big beans" (BB).
- socket 8 for mains supply 220V, 50 / 60Hz (6A).

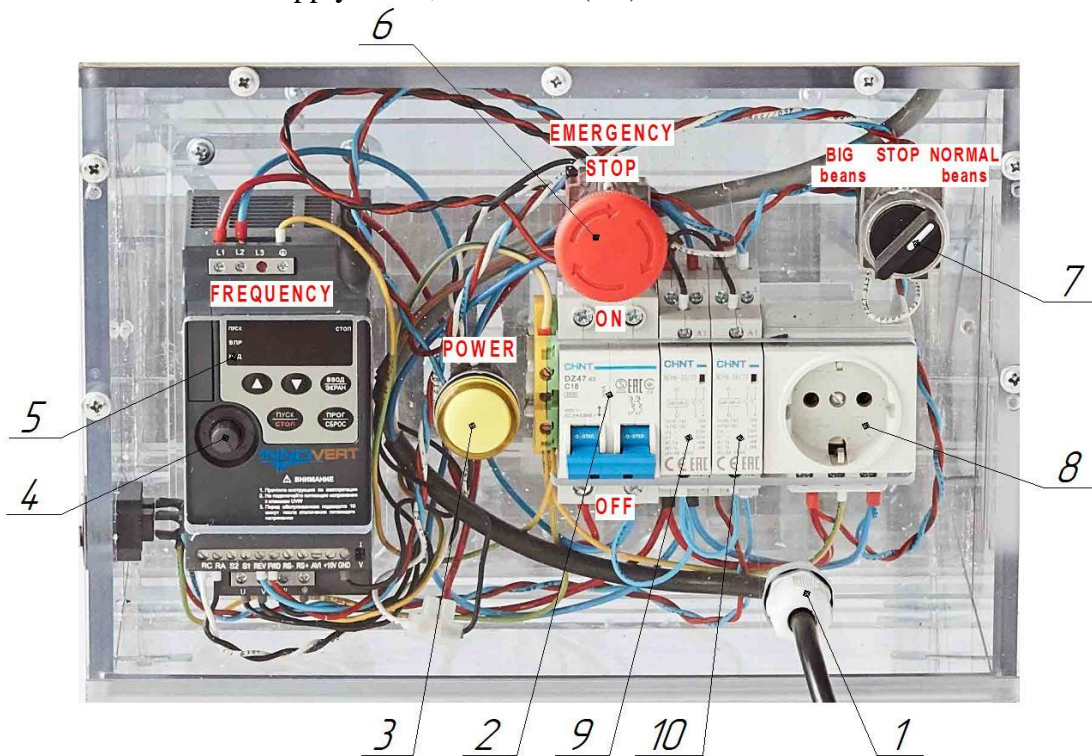

Figure 3

3. Technical data and specifications

3.1 Technical data Separator with Crusher

Main parameters and dimensions shall be in accordance with table 2.

Table 2.

No p/p	Description of parameters	Values
1	Power supply (1-phase)	230 v ~ 50 Hz
2	Power of main motor (kW):	0.25
3	Efficiency, kg/h	Up to 40
4	Overall dimensions, mm	700x305x h1600
5	Weight, kg, net	75

3.2. Electrical connection Conditions of the separator with Crusher

The Machine power is supplied by single-phase mains with Earth and the following characteristics:

- voltage 230 V \pm 10%;
- frequency of 50 \pm 1 Hz;
- power, not less than 1.0 kW.

4. Safety

4.1. General requirements for the safety

The Manual provides the basic safety instructions on handling Machine, including transportation, storage, operation, maintenance, repair.

Safety at work on the Machine is ensured activities in the design of the Machine in accordance with the requirements laid down in European standards, norms and guidelines. Despite this, the Machine can be dangerous in cases of misuse by unqualified personnel or use for other purposes.

The danger situation is possible:

- for the health and life of the operator or third party;
- damage to the separator with a crusher, and other property.

Any person who maintains moving the Machine, its commissioning, maintenance and repairs, must read and understand this manual and in particular the section "safety requirements" and strictly implement the guidelines requirements!

Requirements for security, besides this chapter are contained in the relevant sections of the Manual and applications delivered.

The following safety instructions must be observed in addition to the General requirements for the safety and injury prevention.

4.2. Security measures

4.2.1. The danger warning Signs

In this guide, the danger warning signs, have the following meanings

	Mechanical danger that threatens the life and health of people, and can also cause great material damage to property.
---	--

	Electric danger that threatens the life and health of people, and can also cause great material damage to property.
---	--

The danger warning symbols are applied on Machine, with the following meanings

	Electric danger that threatens the life and health of people, and can also cause great damage to property. The sign is located on the side of the control unit figure 2.
---	---

	Mechanical danger that threatens the life and health of people, and can also cause great damage to property. The sign is located on the side wall of the bunker 6 (fig.2)
---	--

	Inattention to warning signs and non-compliance with the safety instructions can lead to serious consequences for the health of the personnel and material damage!
--	---

Damaged and lost danger warning signs must be restored without fail!

4.2.2. Protective and safety devices

Power supply of The Crusher/Separator is maintained by a separate electric line equipped with the cabinet and the circuit breaker with thermal and overcurrent protection inside.

Protection against spontaneous start of the drive after restoring failed voltage supply is provided by the control unit, which establishes on its outputs the control signals to Zero after power is restored.

The most probable reasons for current protection activation are: jamming, failure or overheating of the motor, the deviation from the normal electrical network parameters.

4.2.3. Requirements for service personnel

General requirements for service personnel

Personnel authorized to work with Machine, as well as to commissioning, maintenance and repair the Machine, is obliged to:

- get health and safety training in accordance with the manufacturer's instructions, developed on the basis of the operating instructions, standardly applied safety instructions;
- familiarize with the General rules of operation and maintenance of the Machine with safety instructions contained in this manual;
- familiarize with constructive and technological properties of the Machine and attend a special instruction on the work of the Machine of this model.



Responsibilities on maintenance of the Machine should be clearly defined and strictly adhered, that in the part of ensuring security - the competence of each employee is clearly defined. It also means that operation on the Machine in special modes (for example, when setting up) may only be carried out by specially trained personnel!

	<p>Work on electrical maintenance of Machine must be conducted by two trained specialists, having Permit to the maintenance of electric equipment with voltage up to 1000V.</p> <p>Unauthorized individuals in the service area of the Machine are not allowed.</p> <p>Before switching on the voltage after installation or repair of electrical equipment or after a long interruption, ensure correct grounding.</p> <p>Access to the control unit to unauthorized persons is prohibited.</p> <p>Areas surrounding the control unit shall not be cluttered or jammed.</p> <p>Failure to comply with these requirements may result in electrical hazard or its risk possibility!</p>
---	--

Dismantling or disabling any security devices is - unacceptable.

	<p>Working with disconnected security devices, gives rise to all kinds of mechanical and electrical dangers.</p>
---	---

The operator must always maintain the Machine in perfect condition. Keep work area clean.

	<p>If there is dirt or foreign objects, if there is no order in the arrangement of the workplace tools, devices, movable goods etc. - there is a danger of confusion, slipping, or being hit by falling heavy objects on lower limbs.</p>
---	--

Errors, noises and obvious flaws shall immediately be reported by service personnel to the person in charge and recorded in the work registry. In the case of danger - Machine should be immediately shut down.

The use of personal protective equipment

When operating the Machine the personnel, as appropriate, should use personal protective equipment:

- dust masks with appropriate filters (when shipping products or materials that emit harmful substances in the work area that can get into the lungs);
- durable thick gloves to protect hands from mechanical damage during technical maintenance and repairs;
- Sturdy boots with soles to prevent slipping (if slippery fluids are used in production) as well as protecting the operator legs from injuries (protection from pinching or falling objects);
- special robe, which could not catch hold of parts of Machine. Sleeves should be rolled up only inwards. Loose clothes, ties, neckwear, jewelry watches, rings, bracelets, etc. are dangerous;
- headdress, closing the hair;
- earplugs (hearing protection from noise) if necessary.

4.3. Security measures during transportation and installation of the Separator / Crusher

When installing the equipment you need:

- check the Separator / Crusher (damage during transportation);
- training the customer's personnel;



During transportation no people should be in the danger zone!

4.4. Security measures when preparing the Machine

Before turning on the Machine - make sure that its start is not dangerous for people around, remove from the Machine foreign objects out of the work zone, become familiar with the device, the principle of operation and control system of Machine.

After installation of the Machine, before connecting it to a power line, you must make the plant measurements of electrical resistance between earth bus and any metal part of the Machine with the elements of electrical equipment that may be energized above 25V through wire insulation breakdown. The measured resistance should not exceed 0.1 ohms.

Connection to power of the Machine must be carried out by a qualified and trained electrician. He must familiarize with electric diagrams and understand them, and ensure correct grounding connection of the Machine.

4.5. Safety when operating the Machine

Do not disable the locks, foreseen in the wiring diagram!



When you disable locks of Machine, foreseen in the wiring diagram it may lead to **all kinds of mechanical and electrical hazards**.



When you turn on the mains switch, the input signal green led lights up, which signals the presence of voltage in the Machine.
Neglecting this information increases the risk of **all types of mechanical and electrical hazards**.



The Separator / Crusher should be disconnected from the mains supply at the end of the work. Failure to do so leads to **an increased risk of electrical hazards**.



After pressing the button 6 (fig. 2) **on control unit**, the hazardous voltage remain on switch input contacts, and contacts of clamp terminal set. Disregarding this information increases the risk of **all types of electrical hazards that threaten the lives and health of people**.

Do not use the Machine in dangerous (for example, wet) environment because humidity can cause short-circuits in the electrical system.



When you use the Machine in a wet environment on the surfaces of the Machine, which typically do not have contact with powered parts and which the operator may touch, can **dangerous high voltage** appear.

Dangerous zone between the Machine and other equipment in the production room (if available) should be fenced or protected by the user.

Ensure sufficient illumination of the workplace (at least 150 Lux).

	Do not work in dark workplace for higher risk of errors of the operator and the breakdown of the Machine .
---	---

Follow the recommended in the manual operation modes of the Machine.

	Failure to follow recommended in the manual operation mode of the Machine increases risk of damage of the Machine and/or injury to the operator.
---	--

Machine is not intended for use with flammable and explosive materials.

	When using inflammable or explosive materials, there is a risk of fire and/or explosion .
---	--

When using materials that emit harmful substances with concentrations exceeding the permissible limit, we recommend that you:

- identify the type of hazard;
- conduct a risk assessment that takes place during the Machine processes the product;
- develop a security system for this product;
- provide the necessary accessories, such as devices monitoring, or remove harmful substances, shut-off devices, quickly triggered before a dangerous product will get into the hands of others, due to the specifics of a particular production.
- to reduce the concentration of harmful substances in the air of the working area by the exhaust hood system and use a reliable ventilation in accordance with the characteristics of production and local regulations on labour protection;
- use of personal protective equipment.

	Failure to follow the recommendations of this manual on transportation of hazardous materials, leads to the risk of contact or inhalation of hazardous gases or dusts (risk of damage to the skin, eyes, and respiratory tract irritation, as well as diseases of the internal organs) .
---	---



Since the list of harmful materials is very wide, this guide does not provide recommendations for all occasions.

Compliance with these recommendations does not exempt the user from performing additional security measures due to the specifics of a particular production.

Do not stand on the separator with crusher in carrying out any of the works.

	Failure to do so could result in overturning the Machine, which leads to an increase in the risk of all mechanical hazards that threaten the lives and health of people, and can lead to great material damage.
---	--

4.6. The technical design changes



Any modifications or changes in the Machine unauthorized by the manufacturer are not allowed for reasons of safety for people and the Machine.

The user can use the spare and wear parts recommended by the manufacturer only.

Otherwise, the manufacturer is not liable for the operability of the Machine.

4.7. Machine noise level

In standard operating conditions the Machine operator workplace noise level does not exceed 60 DBA. The Machine in typical conditions (load the hopper from 1 kg of cocoa beans, the noise level does not exceed 75 DB(a). Uncertainty of measurement of noise conforms to ISO 3746 and 95% probability with confidence equal to $\pm 1.96 O_R$ of the measured values, where $O_R = 3$ DBA.

Noise characteristics were measured in accordance with the methodology of ISO 3746-95 and ISO11204-95 in the light of the requirements of BS EN 415-3: 2000.

A black triangle with a white exclamation mark inside, indicating a warning.	<p>At adverse operating conditions, when the average noise level for the 8 hour shift exceeds 80 DBA, one must use safety equipment (ear muffs, ear plugs), and/or reduce the time in these modes.</p>
--	---

The above values of noise level are not necessarily safe for work on the Machine. Despite the existence of a correlation between emitted and perceived noise, this cannot be used as a reliable option to determine whether or not you want to take further precautions.

Factors influencing the practical level of perception of the noise emitted include the characteristics of the working premises, other noise sources, etc. e.g. the number of Machines, and other related processes, as well as the time during which the operator is exposed to noise. However, the above information will allow the user to assess the dangers and risks faced by staff.

4.8. The residual risks

The personnel requirements specified above reduces the residual risks to Machine of this model to the level achieved in the same equipment, adequate security of which is proven by the experience of its operation.

However, the personnel must know and remember of the existence of residual risks, because the fulfilment of the above requirements **are not completely eliminating the danger.**

5. Scope of supply, marking, packing, storage, unpacking and handling

5.1. Scope of supply

The scope of supply is provided in the packing list, which is composed in accordance with the contract for the Machine.

5.2. Marking

5.2.1. Each Machine has on its frame side surface, a nameplate attached containing:

- the country of the manufacturer;
- full company of the manufacturer;
- the mark of the manufacturer;
- the address of the manufacturer;
- product model, serial number, year of manufacture;
- power supply, voltage and frequency;
- power;
- weight.

5.2.2. The transport marking on the packaging contains:

Main inscriptions:

- full or conventional name of consignee;
- the name of the destination (the station), and the short name of a transport route (road, if necessary); name of reloading place (when necessary);
- package number (in the numerator-the pack number in the lot, in the denominator-the number of places).

Additional inscriptions:

- full or conventional name of consignor;
- the name of the item (the station) of road and short name of the sender (if necessary);
- inscriptions of transport organizations.

Information box:

- the dimensions of the package, santimeters;
- NET and gross weight, kg;
- cargo volume, m³.

Manipulation signs:

- "Beware - delicate";
- "the place of slinging";
- "Top, do not tilt";
- "Center of gravity";
- "do not stack";
- "No Humidity".

5.2.3. Additionally cargo space is indicated by:

- model of the Machine;
- serial number of the Machine.

5.3. Packaging

Machine comes in a crate or a partial package on a pallet, film wrapped. The type of packing is negotiated with the buyer and is fixed in the contract on delivery.

All the Machine accessories, spare parts and documentation are packed in boxes, placed in a box for Machine packing or next to it (on partial packing) and securely fastened.



The manufacturer is not liable for damage of the Machine, occurred during the transport in package inadequate to normative and technical documentation of the manufacturer.

5.4. Acceptance



When receiving the Machine check the integrity of the packaging. The manufacturer does not hold liability for the Machine, delivered with damaged factory packaging.

Found damage should be confirmed by the forwarder by a note in the transportation documents.

5.5. Storage

Storage of packaged Machine shall be:

-for any climate areas in heated and ventilated warehouses under the following conditions:

-ambient temperature: (+5-+40)°c;

-relative humidity: not more than 80% at 25°c;

-Dew is not allowed;

-the impact of corrosive gases is not permitted.

Storage at temperatures below minus 20° (C) may damage electronic components.

	Failure to follow recommended storage mode increases the risk of damaging the Machine and/or injury to the operator.
---	--

Warranty storage period Machine in the factory packaging 1.5 years under specified storage conditions.

5.6. Unboxing

When unpacking, it is recommended that you first remove the top board of packing box and then the side boards. Care should be taken not to damage the Machine by the tools during unpacking.



Before unpacking the Machine should be kept under operating conditions temperature to align Machine temperature and facilities (usually 24 hours).

When unpacking, verify the completeness of the delivery against the packing list and/or for possible damage during transportation.

If there are discrepancies, please contact your manufacturer.

5.7. Transport

Machine can be transported by any means of transport provided a reliable fixation and packaging ensured to keep from damage, in accordance with the rules of transporting goods, applicable for each mode of transport.

Transportation must be subject to the following conditions:

-ambient temperature: (-20 to + 50)°c;

-relative humidity: not more than 98 per cent at temperature of 25°c;

-Dew is not allowed.



Transport at temperatures below minus 20° (C) may damage electronic components.

	<p>Failure to follow recommended guidelines conditions of transportation increases the risk of possible damages of the Machine and/or injury to the operator.</p>
---	---

Before delivering the Machine carefully plan its unloading and transport to the place of installation. At the time of the delivery transport and lifting devices must be fully prepared. Before delivering the Machine remove possible obstacles for the transportation from the place of unloading to place of installation.

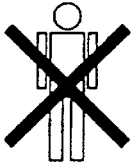
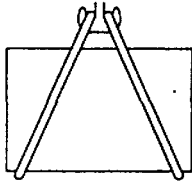

When un/loading the presence of people in the danger zone is not allowed!

	<p>Personnel performing the work on the transport must have appropriate qualifications.</p> <p>Before the beginning of works on transportation requires that staff are kept up to date with security requirements as described in this manual in the section "safety precautions during transportation and installation."</p>
---	--



Incorrect handling can lead to an accident or cause damage or malfunction of Machine, for which the manufacturer is not liable.

	<p>Use vehicles only with sufficient carrying capacity, i.e. more than the transported weight!</p> <p>The weight of packed <i>Machine</i> is specified on the box.</p> <p>When you unload the <i>Machine</i> in packed form, make sure to follow the instructions marked on the outside of the package!</p> <p>During transportation to the place of installation and when placed on the floor, ensure that <i>Machine</i> is not subjected to strong shocks or drops.</p>
---	--

The scheme of slinging and moving the Separator-crusher on the territory of the enterprise in unpacked form using lifting equipment is shown in Fig. (4).

Corrugated cardboard gaskets are used between the slings and sharp corners in the appropriate places.

	<p>STRICTLY COMPLY WITH THE SCHEME OF THE STRAPPING AND INSTRUCTION SECURITY!</p>
---	--

Figure 4.

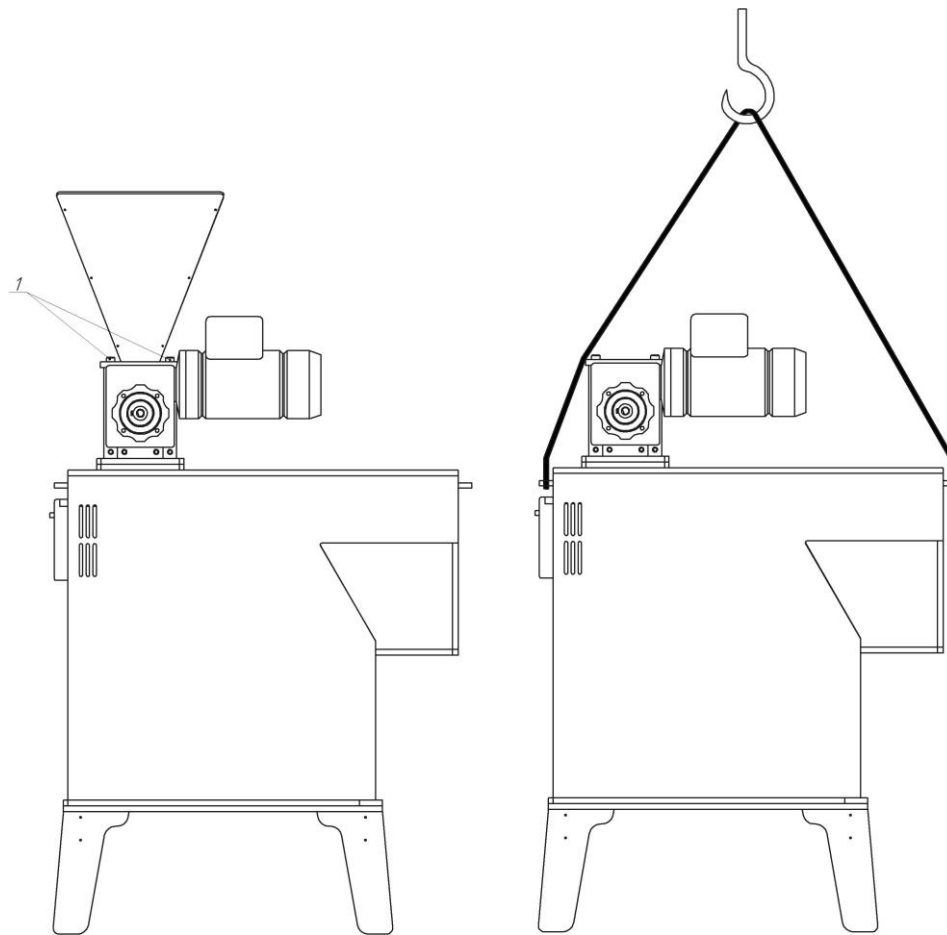

6. Installation and initial start-up

6.1. Installation location and Foundation

The floor foundation should be firm for ensuring the maximum use of Machine capabilities during the specified period of service, and avoid the impact of Machine on the adjacent equipment.

Machine does not require special foundation and is not anchored to it. It is enough to ensure the flat floor of sufficient load-bearing capacity and space.

There must be sufficient space for the operator and the maintenance and repair (not less than 1m around the Machine).

6.2. The Climatic operation conditions

Machine is designed for operation in premises with artificially controlled climatic conditions, for example in closed heated and ventilated premises (no direct sunlight, rain, wind, sand and dust from the outside air, the absence or substantial reduction of impacts of condensation of moisture) under the following conditions:

- ambient temperature: (+5-+40) °C;
- relative humidity: not more than 80% at 25°C;
- dew is not allowed;
- the impact of corrosive gases is not permitted.

The temperature variation of the workspace is not specified.

Dust content of the work shop shall be within sanitary norms.

The place of installation of Machine should be selected in such a way as to exclude local heating or cooling (Sun, heating, draughts, etc.).

Machine is not intended for use in explosive environments or near inflammable objects.



If you fail to comply with the requirements, there is **the danger of fire and/or explosion**.



The manufacturer is not liable for defects or injuries caused because of non-compliance with the requirements on service conditions.

6.3. Installation of the Machine

1. Place the Crusher/ Separator in a vertical position (see fig. 2.).
2. Connect the corrugated hose 6 of the Crusher/ Separator to the air flow device 8 (vacuum module).
3. Check the reliability of the connection of the removable separation module with other parts of the Crusher/ Separator. Check the connection of the electric power cable of the vibration motor of the removable separation module.
4. Install the inner and outer GN containers to collect the cocoa nibs.
5. Connect the ground crocodile clip (red) to the retractable metal plate, as shown in Fig.4-1.



Fig. 4-1

7. Order of work

7.1. Switching on/off the separator with Crusher

The equipment is controlled from the control unit.

After connecting the Separator /Crusher to the mains, the indicator led 3 (fig.3) should light up on the front panel of the control unit, that shows the presence of power and readiness for to starting the equipment.

If the indicator does not light up, turn on the protection circuit 2 (figure 3).

On display 4 (fig. 3) digit 30.00 should be displayed. Turn the knob 4 (fig. 3) in the decreasing direction all the way until the knob stops.

Turn on the the air flow device (vacuum module).

To start the rotation of the Separator-crusher roll, switch 7 must be set to the "Normal beans" (START) position. Use knob 4 (Fig. 3) to set the required roll rotation speed. Recommended speed = 50 Hz. To turn off switch 7, move to the vertical position "STOP".



Staff should not have clothes with hanging straps, belts, etc. in order to avoid falling into the rotating parts!



Observe the extra care near running equipment. to avoid injury. DO NOT produce any action inside the bunker!



In case of emergency immediately unplug the equipment from the electrical circuit!



7.2. Emergency Shutdown of separator with Crusher

In the case of emergency to stop the separator with a crusher, you must:

-Press the red « **STOP** » button 6 (fig. 3) on the front panel of the control unit and disconnect from the power electricity supply.

8. Maintenance

8.1. General safety instructions for maintenance

	<p>Maintenance the separator with crusher and repair work must only be carried out by trained, qualified and certified technicians. Before the beginning of works on maintenance service and repair personnel must familiarize with section "Security Insurance".</p>
	<p>Before starting any maintenance work on separator with crusher the unintentional switching on must be avoided. The power supply must be switched off.</p>
	<p>Hang a warning label on the control unit to avoid accidental pressing of buttons or switches. Install fencing to prevent access or interference by unauthorized persons.</p>



Regular maintenance is essential for safe and long faultless operation of the Separator with Crusher. The maintenance described in this section must be carried out in a timely basis.

Following maintenance work, make the record in the maintenance log book with a brief description of the work, responsible executor, and the date of the work.

No log entries may result in denial on warranty service Separator with Crusher manufacturer.

On any maintenance subject you can get a free consultation from manufacturer.

8.2. Scope of maintenance work

The scope of works on maintenance service includes:

1. Checks to be done daily before the separator with a crusher is started;
2. Works performed monthly.

8.2.1. Daily maintenance

1. Make the external visual inspection of the unit.

The Separator / Crusher should be kept clean. Dust Separator with the crusher can be removed with a vacuum cleaner or a dry cloth, and when necessary with damp cloth with neutral detergent, preventing the accumulation of water on the surface.

8.2.2 Weekly maintenance

1. Disconnect the power plug from the outlet.
2. Clean off adhered vella from the Crusher with a stiff brush.
3. To access the internal parts of the crusher separator, remove the top cover (2), unscrew the wing nuts (1) (Fig. 5). Clean the inside surfaces. Fold down the panel (5) to access and clean the “shark fins” as shown in Fig. 5-1.
4. Remove the retractable metal panel (4) of the suction chamber for cleaning. After cleaning, reinstall the panel, attach the alligator grounding clip.
5. Clean the metal mesh of the removable separation module and the chute for unloading cocoa nibs into the external gastronome container.
6. Remove the remaining vella through the bottom cover (3). Can be carried out simultaneously with the release of the bottom bag of the Dust Collector from the vella.
7. Check the condition of all fasteners and tighten if necessary.
8. Empty the air flow device (chip suction device) bags from the vella.

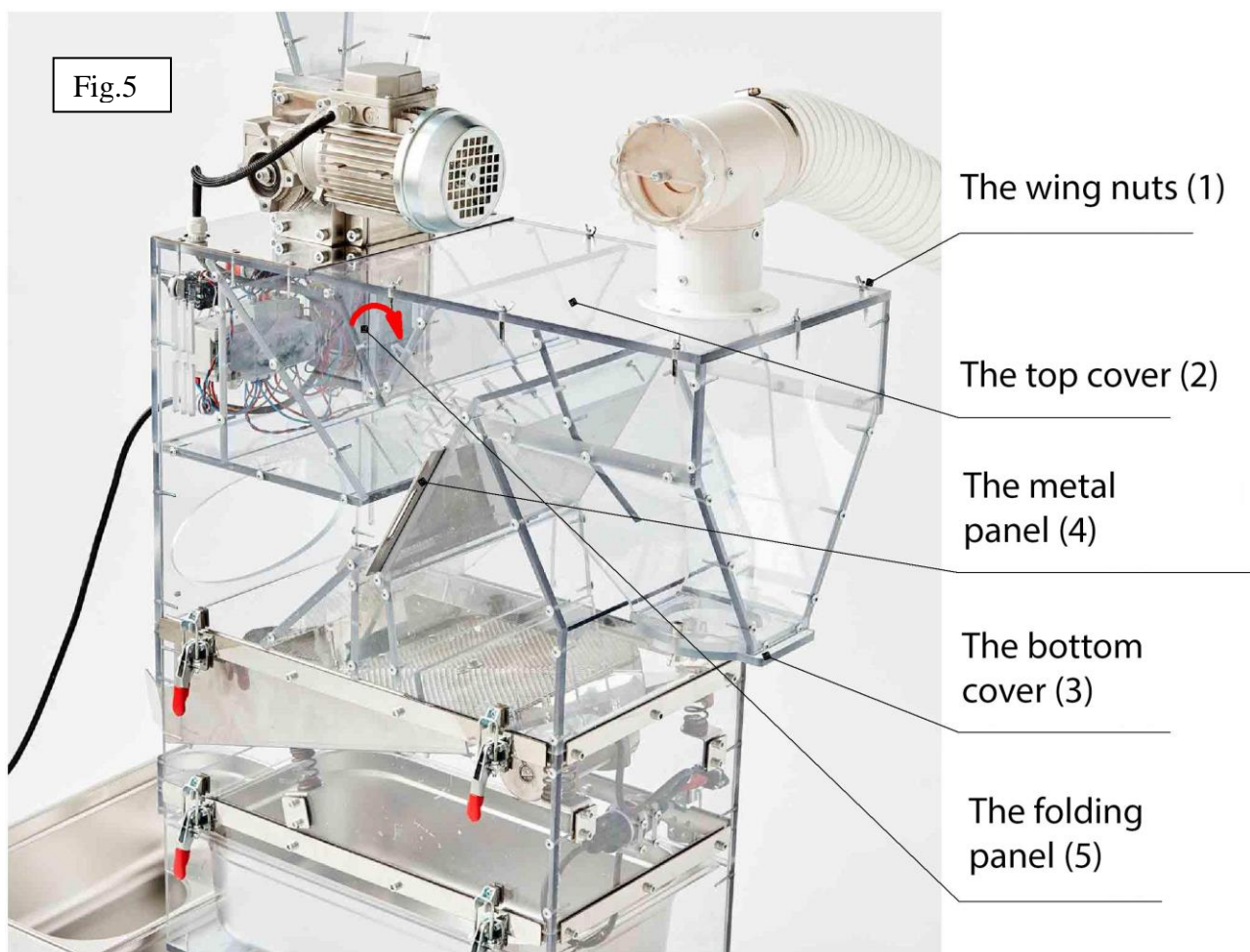

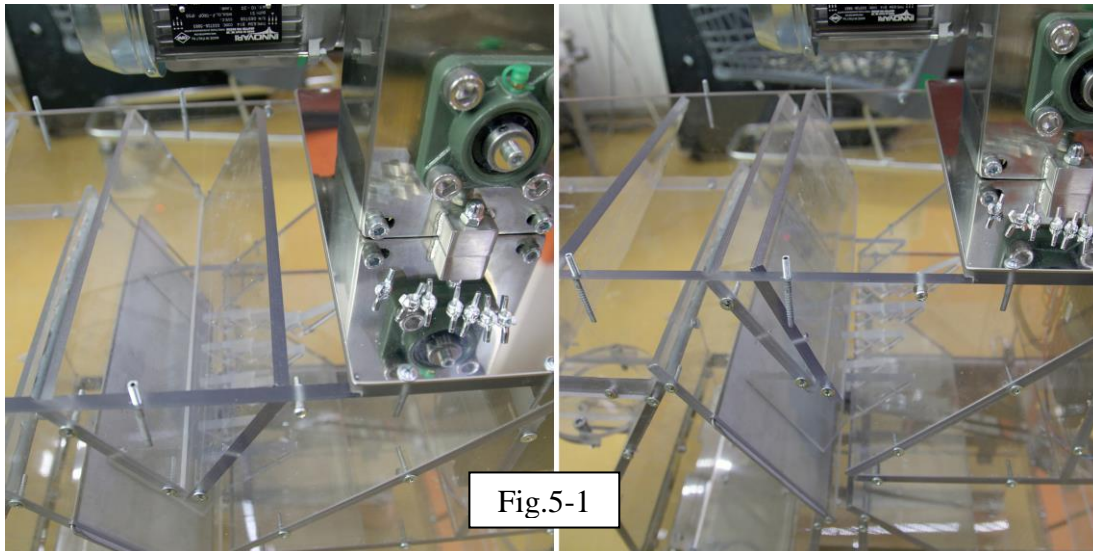

Maintenance of motor gearbox is not required.

9. Spare parts order, call customer service

Ordering spare parts, additional devices, calling the service department for warranty or post-warranty repairs is carried out only upon written request. In the process of technical improvement of the Crusher/Separator, some changes can be made to the design.

Therefore, when ordering spare parts and calling a service engineer, the following data must be indicated in the application: model and serial number of the Crusher/Separator.

This number is indicated in the product passport. It is advisable to purchase components (bearings, electrical equipment, etc.) by type or number printed directly on them indicating the main data or by reference designation in the diagram.

For details that have failed, provide a brief description of the problems with the old part and, if possible, the reasons for which they occurred.

The scope of delivery includes one shear bolt, which can be replaced by the operator himself.

10. Recommendations for use

The advantages of the model: - The Allure CD3 model efficiently processes cocoa beans of all sizes and fat contents. As a result, cocoa nibs are applicable in confectionery without additional purification;

- Allure CD3 has a wider crusher drum with additional notches for better grip of cocoa beans. The Allure CD3 has a switch on the front panel with “Big beans” (BB) and “Normal beans” (NB) positions for large and normal cocoa beans. Now the user does not have to pre-sort the cocoa beans and reduce the speed for crushing large cocoa beans. The production of cocoa nibs has become stable, regardless of the size of the cocoa beans. The "Big beans" (BB) mode is used only for the first pass when loading whole (not crushed) cocoa beans into the hopper;
- installation of a special design cocoa nibs distributor, called "shark fins", made it possible to significantly improve the quality of cleaning cocoa nibs from vella. Now the crushed cocoa beans are evenly distributed throughout the volume of the aspiration chamber without clots and are evenly blown with an air stream;
- to obtain an exquisite taste, texture and aroma of confectionery products, to prepare sprinkles for chocolate bars and bars, to add cocoa nibs to yoghurts, cereals, ice cream and other confectionery products, cocoa nibs are used, the size of which should not exceed four millimeters. The separation module collects fine cocoa nibs into the internal gastronorm container of

the crusher-separator. A coarse fraction of cocoa nibs enters the external gastronome container and is reloaded into the receiving hopper of the crusher-separator. The number of repeated loads depends on the required quality of cleaning the cocoa nibs from the vella. The operating frequency range of the drum of the crusher-separator has been increased to 70 Hz.

To obtain cocoa nibs of normal cleaning, intended for loading into a melanger, the recommended drum rotation speed of the crusher is 70 (NB) -50 (NB) -50 (NB) or for large cocoa beans 70 (BB) -50 (NB) -50 (NB).

For improved cleaning, the frequency of the second and third passes can be reduced to 35 Hz, for example, 70 (BB) -35 (NB) -35 (NB), where:

70 (BB) - frequency in Hertz of the first pass (shown on the display of the frequency regulator on the front panel); switch in the "Big beans" position; whole roasted and cooled cocoa beans are loaded; the rotary valve at the outlet of the crusher-separator is completely closed;

35 (NB) - frequency of the second pass, the switch is in the "Normal beans" position, cocoa nibs are loaded from the external gastronome container;

35 (NB) - frequency of the third pass, the switch is in the "Normal beans" position, the cocoa nibs are loaded from the external gastronome container obtained after the second pass.

Time required to process 10 kg of cocoa beans in the 70-35-35 mode is less than 30 minutes.

The output of cocoa nibs in the 70-35-35 mode is about 83% of the weight of the loaded cocoa beans.

For large, well-fermented and well-roasted cocoa beans, use setting 70 (BB) -70 (NB). Losses of cocoa nibs in the 70 Hz mode are minimal and amount to only 12% of the weight of cocoa beans loaded into the crusher-separator.