



▶ MEM620-BUS



▶ MEM540-BUS



▶ MEM520-BUS



▶ MEM440-BUS



▶ MEM450-BUS



▶ ORDERING INFORMATION

TYPE

- MEM620B = Square flange 63.5x63.5 mm
- MEM540B = Round flange Ø 58 mm CLAMPING FLANGE
- MEM520B = Round flange Ø 58 mm SYNCHRO FLANGE
- MEM440B = Blind hollow shaft for motor coupling
- MEM450B = Blind hollow shaft, fixing by elastic support

INTERFACE

- ECT = EtherCAT

NO. OF TURNS

- M = Multiturn

SHAFT/HOLLOW SHAFT Ø

- 6 mm
- 8 mm
- 10 mm
- 12 mm
- 14 mm
- 15 mm

CONNECTORS POSITION

- Radial
- Axial

MEM540B-ECT-M-6

▶ EtherCAT COMMUNICATION PROTOCOL

Based on the industrial Ethernet communication protocol, the **EtherCAT® interface** is **steady, flexible and fast**, therefore particularly suitable for communication between control systems and peripheral devices, such as I/O systems, drives, sensors and actuators.

MEM-BUS EtherCAT® encoders offer:

- Real Time communication
- Flexible number of nodes
- Easy installation and maintainance
- Net topologies configuration
- Automatic slaves addressing
- Flexible work ranges programming



▶ ELECTRICAL & OPERATING SPECIFICATIONS

Operating principle	Magnetic
Resolution/revolution	8192 steps/rev – 13 bit
Revolutions no.	65536 - 16 bit
Initializing time	< 1s
Data memory	>20 years (No motion – power off)
Fieldbus	EtherCAT®
Supply	10 ÷ 30 Vdc Protection against polarity reversal
Power consumption	2.5 W
Accuracy	± ½ LSB
Connection	2 M12 female connectors +1 M12 male connector
Interference immunity	EN 61000-6-2
Emitted interference	EN61000-6-4

▶ MECHANICAL & ENVIRONMENTAL SPECIFICATIONS

Model:	520 - 540 - 620	440 - 450
Materials: housing / shaft	Aluminium / Stainless steel	
Weight	500 g ca	
Shaft/hollow shaft Ø (mm)	6, 8, 10	8, 10, 12, 14, 15
Revolutions/minute	6000	
Starting torque	≤ 0.8 Ncm	
Inertia	≤ 25 g cm ²	
Max load	80 N axial/100 N radial	
Vibrations resistance (10÷2000 Hz)	100 m/sec ²	
Shock (11 ms)	50 G	
Protection degree	IP67 – IP65 shaft side	
Operating temperature	-30 ÷ 70°C	
Stocking temperature	-30 ÷ 85°C	

▶ MEM-BUS EtherCAT ENCODER PROFILE

- Ref IEC61158-1-6 & IEC61784-2
- Device Profile **CANopen over EtherCAT (CoE)**, CiA DS-406
- Physical Layer: EtherCAT 100Base-TX, Fast Ethernet, ISO/IEC 8802-3
- Output code: Binary
- Cycle time ≥ 1 ms
- Transmission rate 100 Mbit/s
- Transmission: CAT-5 cable, shielded (STP), ISO/IEC 11801

▶ SETTABLE PARAMETERS

- Counting direction
- Measuring steps per revolution
- Total measuring length in steps
- Preset value
- Speed resolution

▶ CONNECTIONS

Connectors IN and OUT
M12 female type, D code

Pin	Signal
1	Tx +
2	Rx +
3	Tx -
4	Rx -

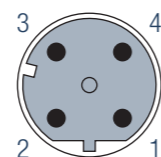

SUPPLY CONNECTOR
M12 male type, A code

Pin	Signal
1	Supply voltage (10 - 30 V DC)
2	N.C.
3	GND (0V)
4	N.C.

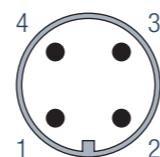

▶ COMMUNICATION MODES

MEM-BUS EtherCAT supports different operating modes:

- **Free-Run:** The slave application is not synchronized to EtherCAT. The local cycle is started by the local timer interrupt of the application controller. The cycle time can be modified by the Master, but this is a local cycle and it does not depend on communication and on Master cycle.
- **SM3 Event:** The slave application is synchronized to the SM3 Event (that is the cyclic inputs transmission to the Master). SM events are based on the time an EtherCAT frame is received. This time can jitter in the range of a few microseconds due to the EtherCAT Master implementation (delay in stack, PHY & MAC delay, etc.).
- **DC:** The slave application is synchronized to the SYNCO event, which is based on the Distributed Clocks Unit (DC). The jitter can be reduced to a few nanoseconds.
- The DC mode grants **high real-time performances**

► MEM620-BUS rif. M1551

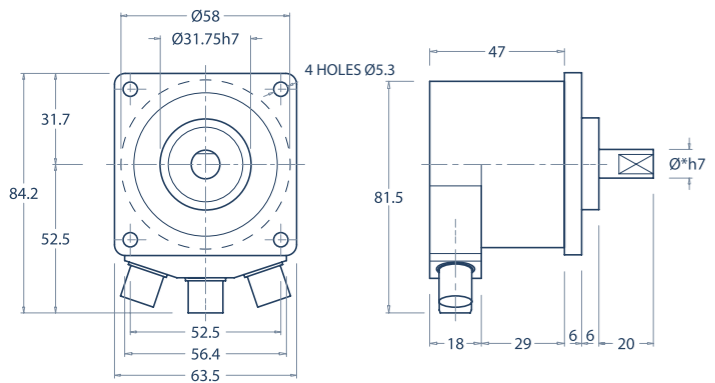

*AVAILABLE SHAFT DIAMETERS
8 - 10 length 20mm
6 length 10mm

► MEM540-BUS rif. M1551

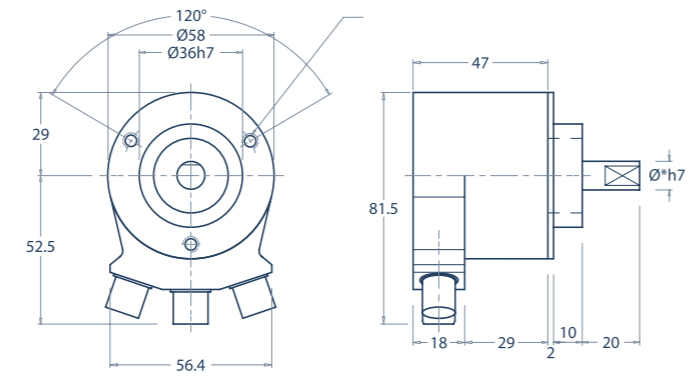

*AVAILABLE SHAFT DIAMETERS
8 - 10 length 20mm
6 length 10mm

► MEM520-BUS rif. M1551

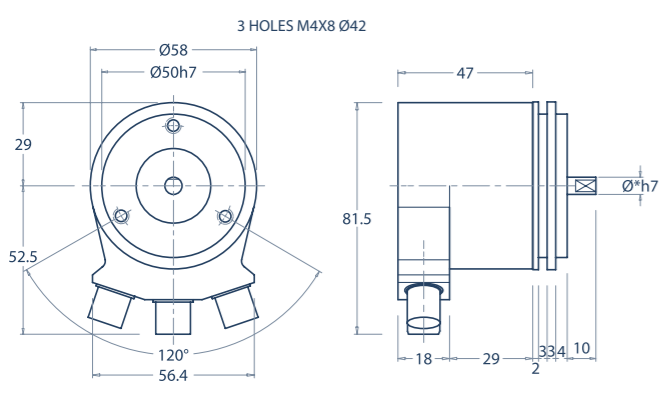

*AVAILABLE SHAFT DIAMETERS
8 - 10 length 20mm
6 length 10mm

► MEM440-BUS rif. M1551B

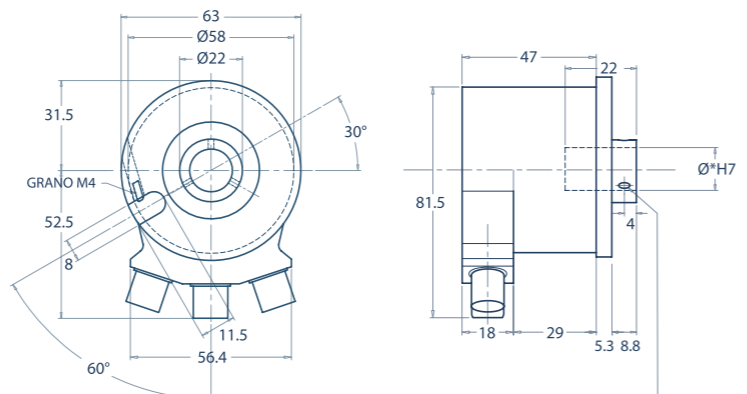

*AVAILABLE SHAFT DIAMETERS
8 - 10 - 12 - 14 - 15mm

► MEM450-BUS rif. M1553B

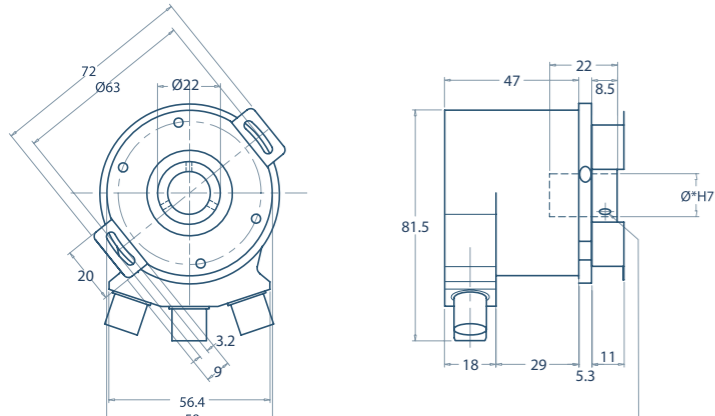

*AVAILABLE SHAFT DIAMETERS
8 - 10 - 12 - 14 - 15mm

► MEM-BUS WITH AXIAL CONNECTORS ref. M2162

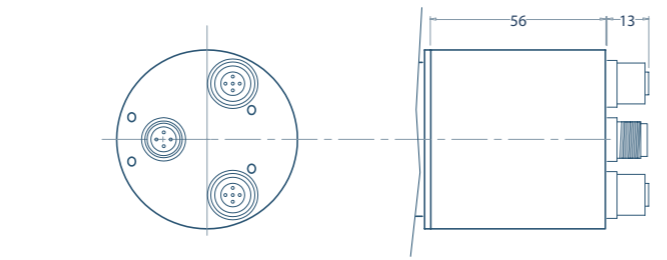

VERSION WITH AXIAL CONNECTORS. REAR VIEW.

EtherCAT
Conformance tested



**ABSOLUTE ENCODER
WITH FIELDBUS INTERFACE**



ELAP srl
Via Vittorio Veneto, 4 - 20094 Corsico (Mi)
tel. +39 02 451.95.61 - fax +39 02 45.10.34.06
info@elap.it - www.elap.it

