

Metal Bellows Coupling I Series KGH-VA

- /// simple installation - split-hub design
- /// wear and maintenance free
- /// variable length // stainless steel version up to 350°C

stainless
steel

technical data:

KGH -VA size	T _N [Nm]	moment of inertia [10 ⁻³ kgm ²]	torsional stiffness [Nm/arcmin]		max. shaft misalignment [mm]				axial spring rate [N/mm]		lateral spring rate [N/mm]		n _{max} [upm]
			2W	4W	axial±	lateral		2W	4W	2W	4W		
10	10	0,03	3,3	2,1	0,2	0,3	0,1	0,15	150	85	2300	400	28000
50	50	0,3	16	9	0,3	0,6	0,1	0,2	130	70	2500	450	17000
120	120	1,2	32	20	0,3	0,6	0,1	0,2	210	110	7000	1200	13000
200	200	2,2	50	28	0,4	0,7	0,1	0,2	170	95	5000	1000	11000
350	350	4,9	93	52	0,4	0,8	0,1	0,2	170	90	7000	1300	9500
600	600	12	190	106	0,4	0,8	0,1	0,2	260	140	15000	2800	8000
1200	1200	39	400	225	0,4	0,7	0,1	0,2	310	160	13000	2100	6000

maximum temperature range: -40°C up to +350°C

material:

bellows: stainless steel 1.4571 / A4

hubs: 1.4301 / A2

screws: ISO 4762 stainless steel

/A4-80

optional: ISO 4762

- 12.9 coated

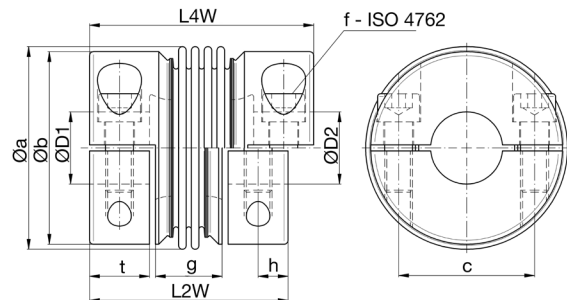

note: connection between bellows and hub by plasma welding

Dimensions [mm]: length dimensions according to DIN ISO 2768 cH

KGH -VA	Øa	Øb	c	f	g		h	L		t	mass ~ [kg]	ØD1/2	
					2W	4W		2W	4W			min	max
10	34	33	21	M5 - 5Nm	18	23	6,5	48	53	13	0,2	7	15
50	56	55	38	M8 - 24Nm	22	32	9	60	70	17	0,7	12	28
120	71	71	50	M10 - 45Nm	32	42	12	82	92	23	1,7	19	38
200	82	82	56	M12 - 80Nm	35	45	13	91	101	25,5	2,5	22	42
350	101	96	68	M14 - 110Nm	35	46	15	101	112	30	3,9	30	50
600	122	116	80	M16 - 180Nm	37,5	53,6	18	115,5	131,5	36	6,7	32	60
1200	157	152	110	M20 - 350Nm	43	59,5	20,5	129	145,5	40	12,6	48	85

Mounting Instructions:

The split-hub design allows for a easy assembly. Further simplification during installation is provided because one half of the split hub is put onto the shaft. This allows that the coupling can rest on the two shaft ends. The second half of the split hub can then be mounted to the coupling by screwing it on from below with the specified tightening torque. This feature makes "one man assembly" possible.

Important: the distance between the shafts must be bigger than 'g'!

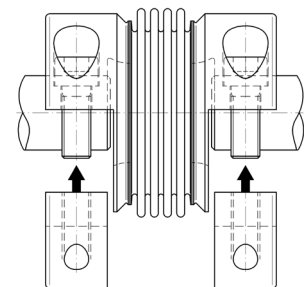

order example: KGH - VA 200 / 4W - D1 = 32^{G7} D2 = 35^{G7} - stainless steel screws
KGH - VA 50 / 2W - D1 = 16^{G7} D2 = 19^{G7} - coated screws