

Swivel Joints

Applications:	<ul style="list-style-type: none"> Used wherever a leak-proof swivel connection is needed in pipelines or in combination with hoses to eliminate hose twisting Industries range from petroleum, petrochemical, refining, mining, distilling, paint, farm irrigation and fertilizing, wastewater treatment plants, and food and beverage process equipment. Dixon™'s swivel joints are found in blending plants, drum filling applications, fluid and dry bulk transfer, vacuum trucks, oil and gas trucks, and water trucks. Larger swivels can be found in the steel industry, marine bulk transfer, and more.
Features:	<ul style="list-style-type: none"> Full 360° rotational movement Wide spacing between dual ball bearing raceways ensures greater load-bearing capacity Precision-machined design ensures alignment and years of trouble-free service O-ring dust seal protects the ball races and seals chamber from outside elements Radius elbow design ensures a smooth flow pattern Hydrostatic testing is performed on all swivels before shipment
Options Available:	<ul style="list-style-type: none"> End configurations: female NPT, 150# flanges, TTMA flange, grooved, weld end, and many other variations Seal options: Buna, FKM, PTFE, EPDM, FDA Buna, FFKM Ball bearing materials: carbon steel, 440 stainless steel, and 316 stainless steel Grease materials: Lithium, FDA approved/food grade and silicone Swivels that include oxygen, steam or submerged service can be specifically designed for unique applications (special order) 100% full penetration weld Re-build kits available Custom swivel options available, contact Dixon™ on +44 (0)1772 323529



B

O-ring Swivel Joints - Parts Identification List

- O-ring (dust) seal
- Ball retainer screw
- O-ring (pressure) seal
- Grease fitting
- Ball bearings

O-ring Features:

- Sizes: 1"-4"
- O-ring pressure seal ensures a leak-proof seal and smooth rotation with lower torque.
- Available working pressure ratings up to **1000 PSI** (6900 kPa)
- Available in carbon steel, 316L stainless steel, aluminium, brass, and malleable iron

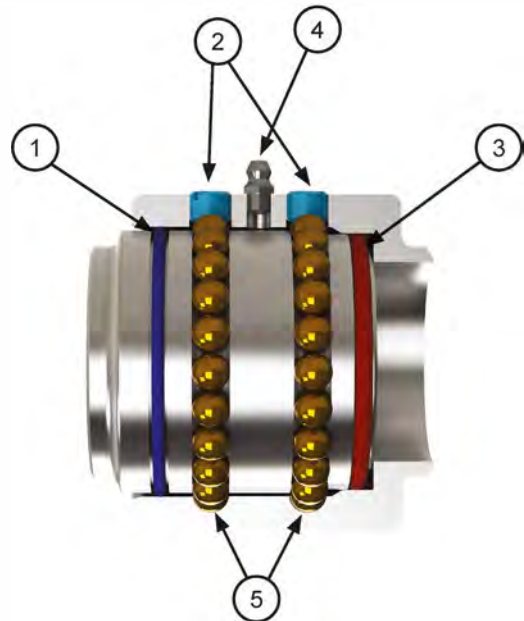

V-ring Swivel Joints - Parts Identification List

- Body
- Sleeve
- Ball bearings
- Seal retainer
- V-ring (pressure) seal
- Spring retainer
- Ball retainer screw
- Grease fitting
- O-ring (dust) seal

V-Ring Features:

- Sizes: 2"-12"
- Spring loaded triple V-ring sealing system ensures a leak-proof seal at either high or low-pressure, and extends seal life
- Available working pressure ratings up to **1000 PSI** (6900 kPa)
- Available in carbon steel, 316L stainless steel, and limited aluminium

