

Zumbach

SWISS PRIME MEASURING SINCE 1957

ZUMBACH PREHEATER



In-Line Induction

WIRE PREHEATING – THE KEY TO BETTER EXTRUSION RESULTS

In-line inductive wire preheating enhances productivity and product quality. Repeatable and uniform conductor temperature helps shorten start-up times and reduce scrap production. Many compounds can only be extruded onto an adequately preheated conductor.

Main benefits of wire preheating

- Better product quality and improved consistency
- Dielectric properties of the insulation material are more uniform and the process conditions are reproducible (important for category type data wires)
- Improved cell structure in case of foamed and foam/skin insulating material
- Higher line speeds are possible thanks to lower stress within the insulation materials
- Shorter start-up times = less scrap
- Preheating allows control of the bonding of the insulation material to the conductor
- Uniform conductor temperature maintained even during ramping phases
- Lasting improvements of the Cpk value
- The aging characteristics of the insulation are improved substantially through better uniformity (reduced risk of insulation cracking due to mechanical stress, e.g. bending of the wire)
- Oil and water residues on the conductor surface are cleaned away by evaporation

FEATURES AND HIGHLIGHTS

- **VISU-Touch – PoE (Power over Ethernet) Webserver Operator Screen**

Rugged and compact 7" capacitive Touch Screen. VESA mount installation for flexible operator display positioning at the desired location. Allows for the operator to set up the preheater and turn on/off without having to be local to the preheater. (requires optional connection cable).



- **Material recipe**

System provides recipes for 20 different materials. 3 fixed and 17 configurable to define custom materials with: Specific Resistance [Ω/m], Temperature Coefficient of Resistance [$1/K$], Specific Heat [$J/(K*kg)$] and Specific Gravity [kg/m^3].

- **Ambient temperature measurement**

The preheater measures the ambient temperature to accurately calculate the temperature increase needed to heat the wire from ambient to the desired preheat temperature.

- **Closed loop temperature control**

The system provides an optional interface for the connection of an external temperature measuring system. These devices offer the advantage to be placed right at the entrance to the extruder for most accurate wire temperature measurement as it enters the extruder accounting for any heat loss.

OPERATING PRINCIPLE OF AN INDUCTIVE PREHEATER

The wire to be heated is looped around the sheaves (pulleys) of the preheater and forms a resistive loop. Based on the resistance of the conductor material, the line speed, cold material (typically at ambient temperature) and preheat temperature, a specific voltage is applied to the loop by an inductor which induces a current into the wire. This heating current is induced inductively and without any contact to the product.

Operating principle

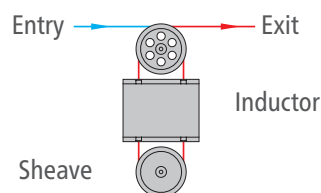

The target temperature can be directly set in degrees (C or F). Preheater will keep that temperature constant, even in case of line speed variations.

Feedback from an independent wire temperature measuring system can be used by the preheater for closed loop temperature control. The preheating action will automatically stop if the line speed drops below a preset minimum, if a wire breaks or if the line stops for any reason.

SPECIFICATIONS

Model	WST.8A.6.20.400-x	WST.16A.12.20.400-x	WST.25A.12.20.400-x
Heating power max.	8 kW	16 kW	25 kW
Wire diameter	0.32 to 1.63 mm (.13 to .06 in.)	0.32 to 2.80 mm (.13 to .11 in.)	1.0 to 3.8 mm (.04 to .15 in.) for stranded wires 1.0 to 2.8 mm (.04 to .11 in.) for solid wires
Input voltage	3 phase 400-460 VAC (360-500 V), 50/60 Hz		
Output voltage	20 V max.		30 V max.
Line speed	6-2500 m/min	6-2500 m/min	6-1700 m/min
Tension force of the line	150 N at 2135 m/min	270 N at 1000 m/min	300 N at 1000 m/min
Max. wire temperature at output	180° C (356° F) (200° C [392° F] if possible) (as option: 300° C [572° F])		
Line height	980-1130 mm (3.22-3.71 ft.)		
Sheave diameter	150 mm / 6" approx.	300 mm / 12" approx.	
Ambient temperature	Operating: 0...45° C (32...113° F), Transport / Storage: -20...50° C (-4...122° F)		
Max. atmospheric humidity	max. 95 % (non condensing)		
Operation altitude	< 2000 m (6562 ft.)		
Type of protection	IP 30 case except for the opening necessary to run the wire through the device. Connection plate also satisfies IP 30.		
Ambient cleanliness	Pollution degree 2 (only non-conductive pollution, occasionally temporary conductivity caused by condensation)		
Integrated interfaces	EN-Ethernet TCP/IP service interface plus optionally one of : – RS: Serial RS-232/-422/-485 host interface – DP: Profibus DP host interface – EN: Ethernet TCP/IP host interface – PN: Profinet IO host interface – EI: EtherNet/IP host interface		

ACCESSORIES

AUTAC 300 – Wire temperature measurement – The perfect partnership for preheating

The AUTAC 300 is used for temperature measurement and control in applications with conductor preheating or post annealing stages. The system consists of a sensor and a processor unit. Non-contact and precise temperature measurement with "Convective Heat Flow Principle" from 10° C to 300° C on wires and cables with a diameter range from 0.2 mm to 7 mm (.008 in. to .28 in.).

The measurement is independent of influencing factors such as colour, emission, speed, material or surface structure meaning the wire. The measuring head is slotted and can be changed without interruption, there is no need to thread the wire.



DIMENSIONS

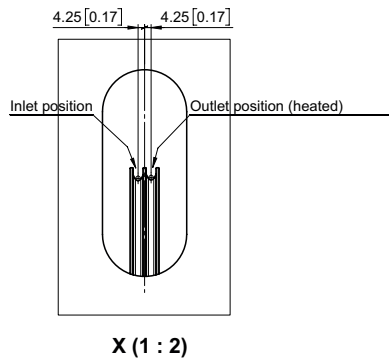
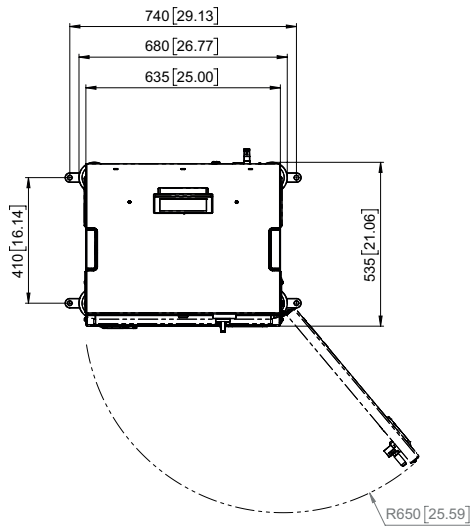
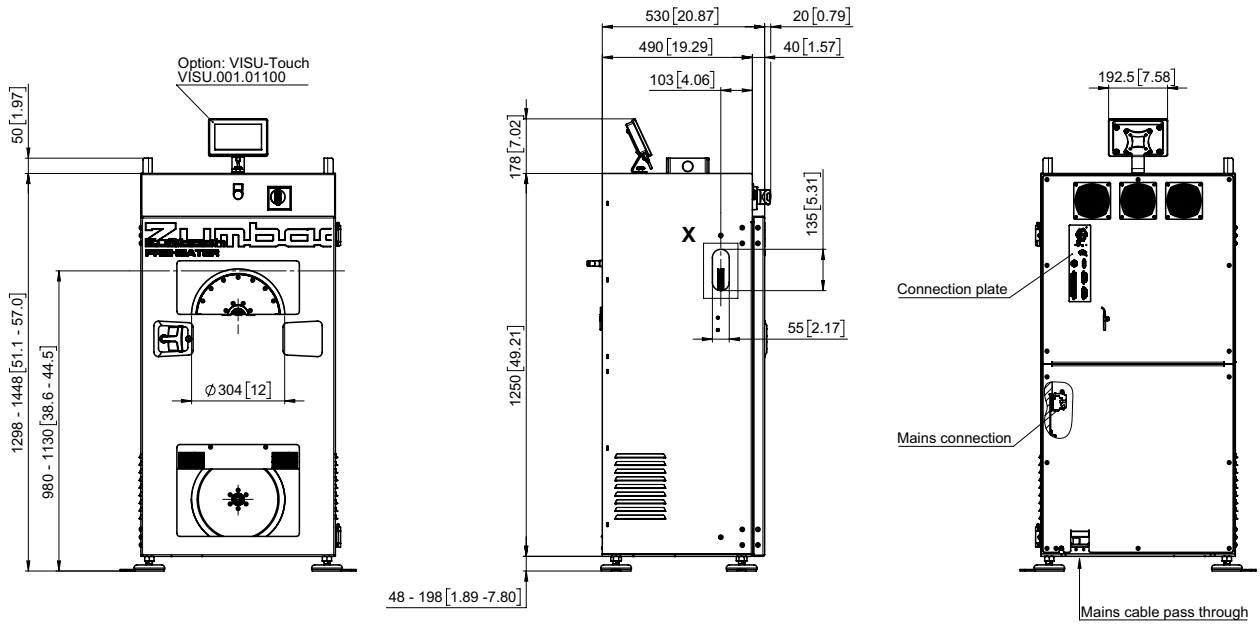

• Technical specifications are subject to change without notice

WORLDWIDE CUSTOMER SERVICE AND SALES OFFICES

Headquarter:
Zumbach Electronic AG
P.O. Box
CH-2552 Orpund
SWITZERLAND
Tel.: +41 (0)32 356 04 00
sales@zumbach.ch

BENELUX, sales@zumbach.be
CHINA P.R., sales@zumbach.com.cn
CZECH REPUBLIC, jvorlicek@zumbach.cz
FRANCE, ventes@zumbach.com.fr
GERMANY, verkauf@zumbach.de

INDIA, sales@zumbachindia.com
ITALY, zumit@zumbach.it
SPAIN, gestion@zumbach.es
TAIWAN, info@zumbach.tw
UNITED KINGDOM, sales@zumbach.co.uk

North American Headquarter:
Zumbach Electronics Corp.
140 Kisco Avenue
Mount Kisco, NY 10549-1407
Phone +1 914 241 7080
USA
sales@zumbach.com

